

Catherine Zucco, Wolfgang Wende, Thomas Merck,  
Irene Köchling and Johann Köppel (eds.)

# Ecological Research on Offshore Wind Farms: International Exchange of Experiences

PART B: Literature Review of Ecological Impacts





**Ecological Research  
on Offshore Wind Farms:  
International Exchange of Experiences  
(Project No.: 804 46 001)**

**PART B: Literature Review of the Ecological Impacts  
of Offshore Wind Farms**

**Editors:  
Catherine Zucco  
Wolfgang Wende  
Thomas Merck  
Irene Köchling  
Johann Köppel**



**Cover Pictures** (clockwise): Sea gull, research platform, benthic community (Krause & Hübner, BfN); Common Seal (Wollny-Goerke, Hamburg); windfarm Rønland (Steinhauer, TU Berlin); windfarm Nysted (background) (Krause & Hübner, BfN)

Editors' addresses: C. Zucco, T. Merck, I. Köchling  
Bundesamt für Naturschutz  
Federal Agency for Nature Conservation  
Außenstelle Vilm  
18581 Putbus

W. Wende, J. Köppel  
Technische Universität Berlin  
Berlin University of Technology  
Franklinstraße 28/29  
10587 Berlin

This publication is included in the literature database "DNL-online" ([www.dnl-online.de](http://www.dnl-online.de))

BfN-Skripten are not available in book trade.

Publisher: Bundesamt für Naturschutz (BfN)  
Federal Agency for Nature Conservation  
Konstantinstraße 110  
53179 Bonn, Germany  
Phone: +49 228/8491-0  
Fax: +49 228/8491-200  
URL: <http://www.bfn.de>

All rights reserved by BfN

The publisher takes no guarantee for correctness, details and completeness of statements and views in this report as well as no guarantee for respecting private rights of third parties. Views expressed in the papers published in this issue of BfN-Skripten are those of the authors and do not necessarily represent those of the publisher.

No part of the material protected by this copyright notice may be reproduced or utilized in any form or by any means, electronic or mechanical, including photocopying, recording or by any information storage and retrieval system without written permission from the copyright owner.

Printed by the printing office of the Federal Ministry of Environment, Nature Conservation and Nuclear Safety.

Printed on 100% recycled paper.

Bonn, Germany 2006

## TABLE OF CONTENTS

<b>1 Literature Review of Offshore Wind Farms with Regard to Benthic Communities and Habitats</b>	<b>1</b>
Karin Meißner & Holmer Sordyl	
<b>2 Literature Review of Offshore Wind Farms with Regard to Fish Fauna</b>	<b>47</b>
Oliver Keller, Karin Lüdemann & Rudolf Kafemann	
<b>3 Literature Review of Offshore Wind Farms with Regard to Seabirds</b>	<b>131</b>
Volker Dierschke & Stefan Garthe	
<b>4 Literature Review of Offshore Wind Farms with Regard to Marine Mammals</b>	<b>199</b>
Klaus Lucke, Sandra Storch, Justin Cooke & Ursula Siebert	



# Literature Review of Offshore Wind Farms with Regard to Benthic Communities and Habitats

Karin Meißner & Holmer Sordyl

Institut für Angewandte Ökologie Forschungsgesellschaft mbH

Alte Dorfstraße 11

18184 Neu Broderstorf, Germany

[meissner@ifaoe.de](mailto:meissner@ifaoe.de)

## Contents

<b>1</b>	<b>Summary .....</b>	<b>2</b>
<b>2</b>	<b>Zusammenfassung .....</b>	<b>3</b>
<b>3</b>	<b>Background and Objectives .....</b>	<b>6</b>
<b>4</b>	<b>Sources of Information.....</b>	<b>7</b>
	4.1 Experience and Data from Offshore Wind Farm Developments .....	7
	4.2 Practical Approaches.....	8
	4.3 Theoretical Approaches.....	8
<b>5</b>	<b>State of Knowledge.....</b>	<b>9</b>
	5.1 Noise and Vibration.....	9
	5.2 Temperature.....	10
	5.3 Electromagnetic Fields .....	14
	5.4 Disturbance.....	17
	5.4.1 Changes in Biotope Characteristics .....	17
	5.4.1.1 Current and Wave Regime .....	17
	5.4.1.2 Disturbance of the Seabed .....	18
	<i>Direct Habitat Loss</i> .....	18
	<i>Scour</i> .....	18
	<i>Contamination</i> .....	20
	5.4.1.3 Habitat Destruction.....	21
	5.4.2 Physical Disturbance and Damage to Benthic Organisms .....	22
	5.4.3 Introduction of New Faunal Components and “Reef Effects” .....	26
<b>6</b>	<b>Conclusions and Recommendations .....</b>	<b>30</b>
	6.1 Effect Monitoring.....	31
	6.1.1 Existing Concepts.....	31
	6.1.2 Proposal for a Monitoring Concept for the Operational Phase of Offshore Wind Farms in the German EEZ.....	34
<b>7</b>	<b>References .....</b>	<b>39</b>

## 1 Summary

A literature review of ecological research on offshore wind farms with regard to benthic habitats and communities is presented in this article. Information was gathered from reports compiled in the course of wind farm developments, research project reports (practical and theoretical approaches), and the scientific literature. Noise and vibration, heat emission, electromagnetic fields and disturbance have been identified as potential impact sources. Available information related to the different impact sources are reviewed in separate chapters. A summary of contents is given below.

### *NOISE AND VIBRATION*

Various source levels of offshore wind farm related noise are available. Studies linking both noise and marine wildlife observations are scarce. Response to noise could be observed under experimental conditions. Under field conditions, avoidance might be the most common response to underwater noise. Colonization of wind turbines is taken as an indication that noise and vibration do not have detrimental effects on the attached fauna. Further studies are required to significantly add knowledge about the effects of noise and vibration on marine invertebrates.

### *TEMPERATURE*

Temperature rise in the sediment is predicted based on different theoretical models. Results of such calculations are cited. Most studies predict the sediment temperature rise not to exceed 2 K at 20 cm sediment depth if the cable burial depth is 1 m. Models also predict much higher sediment temperatures in close vicinity to the cables. Heat emission is discussed in the context of changes in the physico-chemical conditions of sedimentary substrates, which could cause changes in the distribution of species. In the scientific literature, the change of benthic community composition is mainly discussed in connection with thermal discharges from power plants. Also, an assessment of likely effects of seawater warming for particular species is presented.

### *ELECTROMAGNETIC FIELDS*

The occurrence of electric and magnetic fields dependent on power cable type is explained. Data available on both anticipated and measured field strength are reviewed. In conclusion, none of the studies performed to date to assess the impact of undersea cables on migratory fish (e.g. salmon and eels) and all the relatively immobile fauna inhabiting the sea floor (e.g. molluscs), has found any substantial behavioural or biological impact. In regard to benthic marine invertebrates, such effects may only occur in close vicinity to the cables.

### *DISTURBANCE*

Disturbance has been identified as one of the major impact factors in the course of offshore wind farm development. The term "disturbance" includes a number of different impact factors. It is necessary to distinguish between indirect and direct effects. Indirect effects primarily affect the marine environment, and thus secondarily affect the benthic community. Direct effects on organisms include physical disturbance, damage, displacement and removal.

Effects on the marine environment include all changes in biotope characteristics. Such changes discussed include changes of current and wave regime, disturbance of the seabed, and habitat destruction. None of these changes is reported to affect the marine environment on a large scale.



Physical disturbance and damage to benthic organisms is widely discussed in the scientific literature. Contradictory results are presented regarding the effects on benthic communities due to disturbance, but based on the results of the majority of studies, changes in zoobenthic species composition, abundance or biomass are very likely to occur. Species regarded sensitive towards disturbance include e.g. the sea urchin *Echinocardium cordatum* and the bivalves *Phaxas pellucidus* and *Mactra corallina*, the brittle stars *Ophiotrix fragilis* and *Ophiopholis aculeata*, the hydroids *Lafoe dumosa*, *Sertularella* spp. and Campanulariidae. Other species are considered to possess either high mechanical resistance, high mobility or a high potential for regeneration, which enable them to tolerate disturbance. Recovery of disturbed communities is expected to take several years.

Introduction of artificial hard bottom along with the so-called “reef effect” are believed to have the greatest impact at the ecosystem level. Succession in the colonization of artificial hard-bottoms has been investigated in quite a number of studies. Calculation of production rates of epifaunal communities has also been undertaken. The “reef effect” is expected to be confined to the close vicinity of reefs or structure. One example from San Diego Bay in southern California was found where the elimination of a seapen species could be documented within 200 m distance from the artificial reef, probably due to foraging reef fish. In connection with artificial reefs, the benefit for certain species is also discussed.

Most results summarized above are conclusions by analogy. The source of information expected to be most valuable for an assessment of impacts on benthic habitats and communities, surveys undertaken in the course of wind farm developments, was found to be quite limited. The application of effective monitoring concepts in future studies is required.

## 2 Zusammenfassung

Der vorgestellte Projektbericht fasst die Ergebnisse einer Literaturstudie zur ökologischen Begleitforschung von Offshore-Windkraftanlagen hinsichtlich potentieller Auswirkungen auf benthische Evertebraten-Lebensgemeinschaften und Habitate im marinen Lebensraum zusammen. In die Recherche einbezogen wurden Fachgutachten und Untersuchungsberichte, die im Rahmen der Planung und Realisierung von Offshore-Windparks erstellt wurden, Projektberichte zu Forschungsvorhaben, die sich über theoretische oder praktische Herangehensweise mit verschiedenen Aspekten der Offshore-Windenergienutzung beschäftigten, und wissenschaftliche Publikationen. Als potentielle Einflussfaktoren wurden auditive Belastungen und Vibration, Wärmeemission von Stromkabeln, die Entstehung elektromagnetischer Felder und Störung, im Sinne von Störung durch Veränderungen des Lebensraumes und direkte physische Störung der Organismen, identifiziert. Die zu den einzelnen potentiellen Einflussfaktoren verfügbaren Informationen wurden zusammengestellt und in separaten Kapiteln besprochen. Eine kurze Übersicht über deren Inhalt wird im Folgenden gegeben.

### AUDITIVE BELASTUNGEN UND VIBRATION

Ergebnisse von Feldmessungen von Windpark-assoziierten Lärmbelastungen liegen aus verschiedenen Quellen vor. Allerdings sind Studien, die Lärmbelastungen unter dem Aspekt der Auswirkungen auf Organismen untersuchen, rar. Unter experimentellen Bedingungen konnten Effekte auf evertibrate Organismen beobachtet werden. Es wird

jedoch angenommen, dass unter Feldbedingungen Lärmbelastungen gewöhnlich mit Fluchtverhalten begegnet wird. Hinsichtlich der Auswirkungen von Vibrationen wird auf die dichte Besiedlung von beispielsweise Turbinenmasten verwiesen und geschlussfolgert, dass negative Effekte nicht auftreten. Insgesamt ist der Kenntnisstand nicht ausreichend, um abschließende Einschätzungen vorzunehmen.

#### *WÄRMEEMISSION VON STROMKABELN*

Der Temperaturanstieg im Sediment verursacht durch Wärmeemission aus Stromkabeln wurde auf Grundlage von Modellierungen mehrfach untersucht. Die Ergebnisse werden im Bericht kurz vorgestellt. In der Mehrzahl der Studien kam man zu dem Ergebnis, dass bei einer Kabelverlegetiefe von 1 m der Temperaturanstieg in 20 cm Sedimenttiefe 2 K nicht überschreiten wird. Auf Grundlage der theoretischen Modelle wird allerdings auch vorausgesagt, dass die zu erwartenden Temperaturen in größerer Nähe zum Kabel, also tiefer im Sediment, deutlich höher liegen. Die mögliche Veränderung der physiko-chemischen Eigenschaften der Sedimente durch die Temperaturerhöhung und dadurch verursachte Änderungen in der Zusammensetzung benthischer Lebensgemeinschaften werden von Ökologen diskutiert. In der wissenschaftlichen Literatur finden sich verschiedene Arbeiten zu dieser Problematik im Zusammenhang mit Wärmebelastungen durch Kühlwassereinleitungen aus Kraftwerken. Andere Autoren publizierten Arbeiten über mögliche Effekte der Erwärmung des Meerwassers auf bestimmte Arten oder Artengruppen. Die direkte Übertragbarkeit der Ergebnisse solcher Studien auf die Kabelwärmeproblematik ist jedoch nicht möglich.

#### *ELEKTROMAGNETISCHE FELDER*

In diesem Abschnitt wird zunächst das Auftreten elektrischer und magnetischer Felder in Abhängigkeit vom Kabeltyp kurz erläutert. Desweiteren erfolgt eine Erwähnung antizipierter und gemessener Feldstärken. In keiner der bisher veröffentlichten Arbeiten können erhebliche biologische Effekte oder Effekte auf das Verhalten von Fischen oder benthischen Organismen (z. B. Mollusken) nachgewiesen werden. Es wird angenommen, dass Auswirkungen auf marine Wirbellose, sollten sie tatsächlich auftreten, auf den unmittelbaren Bereich um das Kabel beschränkt sein sollten.

#### *STÖRUNG*

‘Disturbance’ oder ‘Störung’ ist nach Meinung verschiedener Autoren als Haupteinflussfaktor im Rahmen der Realisierung von Offshore-Windparkprojekten zu bewerten. Unter der Kategorie ‘Störung’ verbirgt sich eine ganze Reihe von verschiedenen Einflussfaktoren. Zu unterscheiden ist zwischen indirekten und direkten Effekten. Zu den die Organismen direkt betreffenden Effekten gehören physische Beeinträchtigungen und Schädigungen, Verdrängung und Verfrachtung sowie Eliminierung. Indirekte Effekte betreffen primär den marinen Lebensraum und sekundär die benthische Lebensgemeinschaft. Solche indirekten Effekte umfassen alle Änderungen der Biotopeigenschaften, dazu gehören Änderungen des Strömungs- und Wellenregimes, Störungen des Meeresbodens und Biotopzerstörung. Für keine dieser diskutierten Veränderungen konnten großskalige Beeinflussungen nachgewiesen werden.

Physische Beeinträchtigung und Schädigung von benthischen Organismen ist ein recht breit diskutiertes Thema in der wissenschaftlichen Literatur. Die Ergebnisse der verschiedenen Studien sind teilweise widersprüchlich, doch ausgehend von der Mehrzahl der Studien sind Veränderungen in der Zusammensetzung der

zoobenthischen Gemeinschaften sowie Veränderungen der Abundanz und Biomasse durch den Einfluss von Störungen sehr wahrscheinlich. Arten, die als empfindlich gegenüber Störung gelten, sind der Seeigel *Echinocardium cordatum*, die Muscheln *Phaxas pellucidus* und *Maetra corallina*, die Schlangensterne *Ophiotrix fragilis* und *Ophiopholis aculeata* sowie die Hydrozoa *Lafoe dumosa*, *Sertularella* spp. und Campanulariidae. Anderen Arten ermöglicht ihre hohe mechanische Resistenz, große Mobilität oder eine hohes Regenerationspotential Störung zu tolerieren. Die Dauer bis zur vollständigen Regeneration einer gestörten Gemeinschaften wird auf mehrere Jahre geschätzt..

Auf ökosystemarer Ebene wird der Einbringung von künstlichem Hartsubstrat zusammen mit dem sogenannten 'Riff-Effekt' die potentiell größte Bedeutung zugeschrieben. Die Sukzession bei der Besiedlung künstlichen Hartsubstrates wurde in einer ganzen Reihen von Studien verfolgt. Auch wurden Produktionsraten der Aufwuchsgemeinschaften kalkuliert. Hinsichtlich des 'Riff-Effektes' wird angenommen, dass er auf die unmittelbare Umgebung des Riffs bzw. der künstlichen Struktur beschränkt bleibt. Nur in einem Fall, einer Studie in der San Diego Bay im südlichen Kalifornien, konnte beobachtet werden, dass eine Spezies aus einem Bereich von 200 m um das künstliche Riff verdrängt wurde. Als Ursache wurde hier die Prädation von nach Nahrung suchenden Riffischen genannt. Auf der anderen Seite wird auch die Begünstigung einzelner Arten durch die Anwesenheit von Riffen diskutiert.

---

Die vorliegenden Erkenntnisse basieren in der Regel auf Analogieschlüssen, d. h. gezielte Untersuchungen zum Einfluss von Windparks auf benthische Gemeinschaften und den marinen Lebensraum sind bisher nicht in ausreichendem Maße unternommen worden. Die potentiell wertvollste Informationsquelle in dieser Hinsicht, begleitende Untersuchungen bei der Realisierung von Windparkprojekten, ist momentan noch wenig erschlossen. Die Umsetzung effektiver Monitoringkonzepte muss in der Zukunft angestrebt werden.

### 3 Background and Objectives

With the ratification of the Kyoto Protocol in 2002 and its entry into force in 2005, the member states of the European Union have accepted an obligation "...for research on, and promotion, development and increased use of, new and renewable forms of energy, of carbon dioxide sequestration technologies and of advanced and innovative environmentally sound technologies" (Kyoto Protocol to the United Nations framework convention on climate change, Article 2). Also, the increasing public awareness of the limitation of fossil fuels considerably contributes to a higher acceptance of renewable energy use. In recent history, wind energy use was strongly supported and promoted by the German government. With the installation of 16,629 MW onshore by 2004, Germany became the market leader both in Europe and worldwide (DANISH WIND INDUSTRY ASSOCIATION 2003). According to expectations of the International Economic Platform for Renewable Energies (IWR), the global wind energy market will grow dynamically during the coming years (Fig. 1). In Germany, the future development will be based on repowering of old and small turbines and the development of wind farm sites offshore.

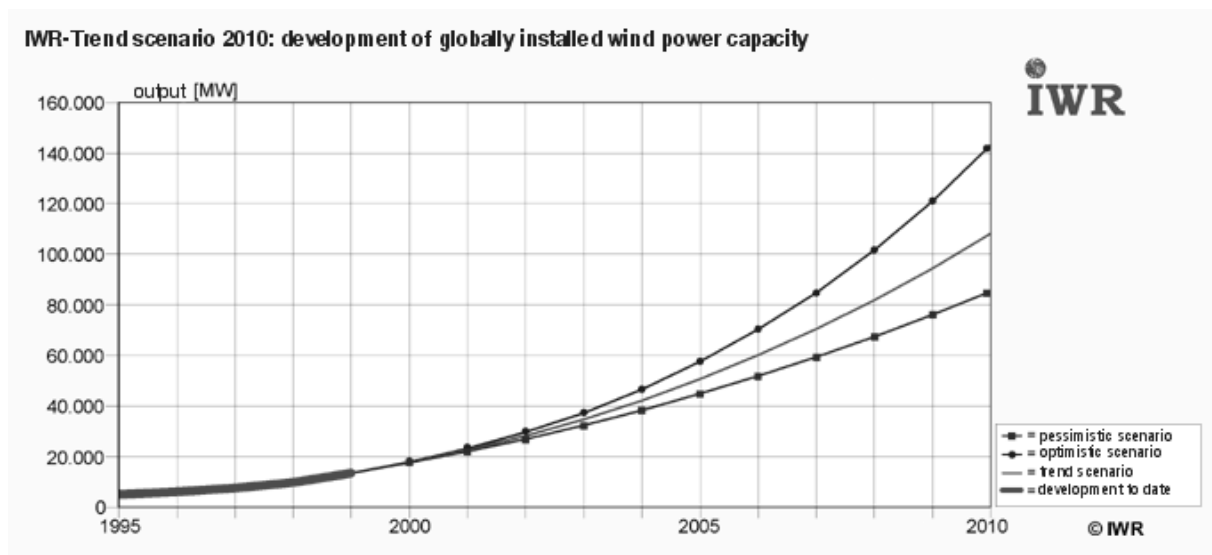

Fig. 1 Trend scenario of globally installed wind power capacity, source: [www.iwr.de](http://www.iwr.de).

Moving developments offshore raises concerns for the protection of the marine environment. The identification and examination of possible impacts is necessary to allow a responsible guidance of this process. The present project report summarises our current state of knowledge and data availability on environmental issues associated with offshore wind farm developments. It is focused on impacts affecting benthic communities and marine habitats.

## 4 Sources of Information

The first step towards the realisation of the project was the identification of valuable sources of information. Methods used for that purpose included a search of such Internet platforms as *Web of Science*, simple key word searches with internet search engines, contact to national authorities dealing with offshore wind projects in various countries, and also personal contact with experts working in the field. As a result, experience and data from offshore wind farm developments as well as other existing offshore industries (e.g. oil and gas, telecommunications and marine aggregate extraction industries), various practical and theoretical approaches, and scientific publications are considered valuable sources. In the following chapters the quantity and relevance of information provided from the different sources is discussed briefly.

### 4.1 Experience and Data from Offshore Wind Farm Developments

The most valuable source of information is expected to arise from the realisation of offshore wind farm projects. Fig. 2 shows the location of proposed wind farm sites in the North and Baltic Seas. As it turns out, the majority of applications for the numerous wind farm projects are still under consideration. Among the larger developments, only a few have started power generation: North Hoyle and Scroby Sands (UK) with 30 x 2 MW-turbines; Nysted Wind Farm (Denmark, Baltic Sea) with 72 x 2,3 MW-turbines; and Horns Rev (Denmark, North Sea) with 80 x 2MW-turbines.

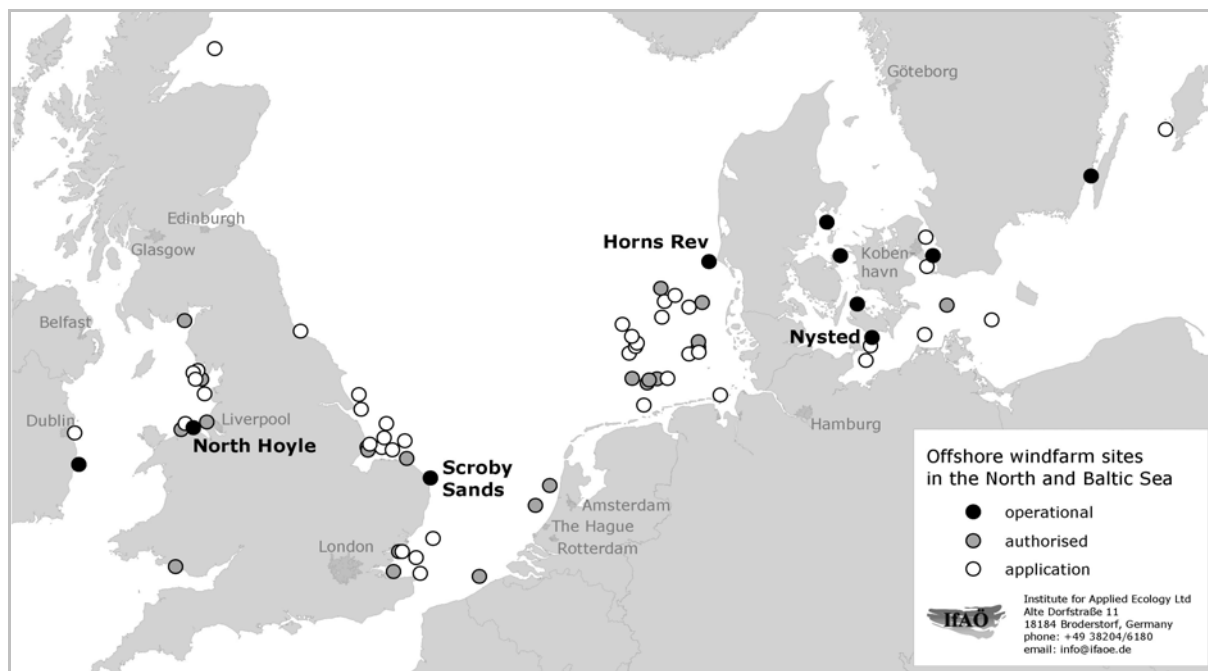

Fig. 2 Location and status of offshore wind farm sites in Northern Europe.

To date, reports from benthic surveys during the construction and post-construction phase are scarce and only those from Nysted and Horns Rev have been made available to the public. These reports are rather comprehensive, and address a number of expected effects. However, the sampling design did not always meet the requirements of successful effect monitoring. Studies have also been carried out at the Swedish wind farm sites of Middelgrunden and Utgrunden, but the reports are either

available only in Danish and hence not fully accessible to the general public, or they are only brief presentations of a few selected results. No reports, except those from the pre-construction phase, are yet available from the U.K. and Ireland, although accompanying research was conducted in the course of wind farm development and during the operational phase.

In conclusion, at the present experiences and data from offshore wind farm developments are very limited and do not provide sufficient information to fully assess environmental effects of such developments.

Tab. 1 Provided reports or info sheets on benthic surveys from operating wind farms.

NAME	COUNTRY	TURBINES	operating	REPORTS
Horns Rev	Denmark	80 x 2 MW	since 2002	several reports from the pre- and post-construction phase
Nysted/Rodsand	Denmark	72 x 2,3 MW	since 2003	several reports from the pre- and post-construction phase
Middelgrunden	Denmark	20 x 2 MW	since 2001	post-construction (in Danish, additional short report in English)
Utgrunden	Sweden	7 x 1,5 MW	since 2001	post-construction phase (in Danish, additional short report in English)
Arklow Bank	Ireland	7 x 3,6 MW	since 2003	pre-construction phase
Scroby Sands	UK	30 x 2 MW	since 2004	pre-construction phase
North Hoyle	UK	30 x 2 MW	since 2003	pre-construction phase

## 4.2 Practical Approaches

Another way of getting a better idea of possible impacts associated with offshore wind farm developments are such practical approaches as the construction of research platforms or field studies at offshore structures of the oil and gas industries. An example from German waters is the research platform FINO I, which has been established in the North Sea and serves as the study site for the research project BeoFINO. The project is conducted by the Alfred Wegener Institute for Polar and Marine Research (AWI), and is financed by the German Federal Ministry of the Environment, Conservation and Nuclear Safety (BMU). The main Goal of BeoFINO is to develop methods and criteria for the investigation of the potential effects of offshore wind farms on marine life. Results from the benthic surveys together with information related to abiotic parameters are expected in summer 2005.

An example for gathering empirical data is the measurement of sediment temperature along power cables at Nysted Wind Farm. This project is funded by the German Federal Ministry for the Environment, Nature Conservation and Nuclear Safety and conducted by the Institute of Applied Ecology GmbH, Neu Broderstorf. Data will be available to the public in 2005.

## 4.3 Theoretical Approaches

There have also been several research projects, such as SCARCOST or GIGAWIND for the development of theoretical models to predict changes in sediment or hydrographic conditions, current and wave regimes or coastal processes. Various authors have compiled reports describing the potential effects of offshore wind farm facilities on marine habitats and species, or coastal processes, based on conclusions arrived at analogy, and the results of modelling. Conclusions can be corroborated by scientific literature, although recent scientific publications on wind farming deal almost exclusively with technical aspects. But there are other publications which have

addressed topics which provide information applicable to wind offshore issues: disturbance of benthic communities caused by the activities of fisheries or oil and gas industries, or by aggregate extraction; studies on reefs and of reef effects, epibenthic colonisation of artificial hard bottoms; or effects of temperature rise, electromagnetic fields or noise.

## 5 State of Knowledge

In the short history of offshore wind energy use, potential impacts and the effects on marine habitats and benthic organisms have been identified. Impacts are expected to occur during various phases of wind farm development, starting with the installation of turbines and the construction of associated facilities, the installation of cables to shore and on site, followed by the operational phase, and finally the decommissioning of the turbines and associated facilities. Impacts can be assigned to five different categories: noise and vibration, temperature, electromagnetic fields, contaminants and disturbance. In the following chapters, the potential effects of these impacts on the marine environment and on benthic communities are discussed on the basis of information available from various sources.

### 5.1 Noise and Vibration

So little research has been conducted into noise and vibration resulting from construction activity and wind farm operation that these factors are apparently not regarded as of significant impact on benthic organisms. However, underwater noise sources are plentiful and include wind farm related geophysical surveys, pile driving, gravity foundation installation, drilling, cable trenching, rock laying, wind turbine operation, vessels and machinery, turbine structure installation etc (NEDWELL & HOWELL 2004). Efforts have been made to quantify underwater noise. A mathematical model for quantification of sound immissions and propagation has been developed and tested in the framework of the research project GIGAWIND, funded by the German Federal Ministry of the Environment, Conservation and Nuclear Safety (BMU). Measurements of piling noise have been taken during construction of platforms in German waters: FINO I in the North Sea, and GEO and the proposed wind farm site SKY2000 in the Baltic Sea. Piling noise has also been measured at North Hoyle and Scroby Sands in the UK. Measurements of operational noise of wind turbines are available from Sweden (the Utgrunden wind farm), and, as reported in NEDWELL & HOWELL (2004), from the United States (San Francisco) and the coastal waters of Canada. The same authors also present source levels for vessels and machinery, geophysical survey, drilling and dredging. VELLA ET AL. (2001) report noise and vibration from human activities (anthropogenic sources such as shipping, dredging, construction, explosion etc.) to be generally in the mid-low frequency range between 10 and 1000Hz. NEDWELL ET AL. (2003) in an assessment of submarine acoustic noise and vibration from offshore wind turbines and its impact on marine wildlife, have published initial measurements from cable trenching at North Hoyle, and also from rock socket drilling. An overview of available data from measurements of offshore wind farm related noise is given in Tab. 2. HISCOCK ET AL. (2002) also provide comprehensive information on major noise sources and characteristics of anthropogenic marine noise. In conclusion, a general idea of noise emission related to offshore wind farms exists, although there are still gaps in the knowledge. As suggested by NEDWELL ET AL. (2003) for wind farm related noise sources, the relative potential for environmental effects is as follows (greatest risk

first): foundation decommissioning using explosives; piled foundation installation and wind farm related geophysical surveying; drilling; rock laying; cable trenching; diver tools; and finally vessels and machinery and wind turbine operation.

Tab. 2 Available information of offshore wind farm related noise (NEDWELL ET AL. 2003, DWI 2004, NEDWELL & HOWELL 2004).

<b>SOURCE LEVELS* OF WINDFARM RELATED NOISE</b>		
*The Source Level is defined as the effective level of sound at a nominal distance of one metre, expressed in dB re 1 Pa @ 1 m.		
<b>Vessel and machinery</b>	152 to 192 dB re 1 mPa @ 1 m	based on measurements of large vessels in deep water and small vessels in shallow water
<b>Geophysical survey</b>	215 to 260 dB re 1 mPa @ 1 m	measurements for airguns, often used in the offshore oil and gas industries
<b>Pile driving</b>	192 to 262 dB re 1 mPa @ 1 m	measurements from different localities worldwide, on average increase with increasing pile diameter
<b>Drilling</b>	145 to 192 dB re 1 mPa @ 1 m	deep water measurements of oil and gas facilities
<b>Trenching</b>	178 dB re 1 mPa @ 1 m	measurements at North Hoyle
<b>Turbine noise</b>	153 dB re 1 mPa @ 1 m	wind turbine capacity less than 1 MW

Underwater noise has the potential of disturbing and even harming marine wildlife, but studies linking both noise and marine wildlife observations, especially marine invertebrates, are hard to find. One article providing information in this context was by LAGARDÈRE (1982). The author investigated effects of noise on growth and reproduction of *Crangon crangon* in rearing tanks. Reduction in growth and the reproduction rate, increased aggression (cannibalism) and mortality rate, and decrease in food intake were observed for specimens exposed to noise levels reaching 30 dB in the 25-400 Hz frequency range. Under field conditions, avoidance might be the most common response to underwater noise. VELLA ET AL. (2001) listed the following results of relevant studies: 1) Sounds in the frequency range 10-75 Hz can cause the heart beat of lobsters *Homarus americanus* to slow down (OFFUT 1970, cited in MCCAULEY 1994); 2) The brittle star *Ophiura ophiura* can detect both near-field vibrations down to a few Hertz and far-field pressure waves (MOORE & COBB 1986); 3) The octopus *Octopus vulgaris* and the squid *Loligo vulgaris* are sensitive to sound frequencies below 100 Hz, with best sensitivity below 10 Hz (PACKARD ET AL. 1990). As to the effects of vibration, the colonisation of wind turbines is taken as an indication that noise and vibration have no detrimental effects on the attached fauna (VELLA ET AL. 2001).

Further studies are required to significantly add knowledge of the effects of noise and vibration on marine invertebrates.

## 5.2 Temperature

In the recent past, little attention has been paid to the potential effects of heat emissions from power cables. In sedimentary substrata, cables will usually be buried, whereas on rocky or other solid substrata, cable may need to be laid on the surface. Burying of cables raises the stronger concerns with regard to heat emissions, although no research has been conducted to date into the effects of heat emissions on the sediment. According to a guideline established by the German Federal Agency for Nature Conservation (BfN) the temperature rise above the buried cable in 0.2 m



sediment depth should not exceed 2 K. A temperature rise which is obviously considered non-harmful to benthic organisms, most of which inhabit the zone within 35 cm of the surface. Based on theoretical models for predicting sediment temperatures in the vicinity of power cables, this guideline can usually be followed if a cable burial depth of 1 m is realised (e. g. BRAKELMANN 2005, EOS OFFSHORE AG 2003, WORZYK & BÖNGELER 2003). The OFFSHORE WIND TECHNOLOGY GMBH (2004) investigated thermal dispersion around cables buried at 3 m depth. The authors predict a temperature increase of about 0.37 K at 0.30 cm sediment depth if full cable capacity is considered, and conclude a lesser increase in temperature than at a cable burial depths of 1 m.

But models also calculate that sediment temperature at greater depths closer to the cable will be much higher, and that the temperature rise might even exceed 30 K directly at the cable (EOS OFFSHORE AG 2003). A study by WORZYK & BÖNGELER (2003) investigates sediment temperature rise in the vicinity of cables connecting turbines and transformer station at a proposed wind farm site in the German EEZ. Preconditions for their calculation model included a cable burial depth of 1 m, a sediment temperature of 6 °C, a turbine capacity of 4.5 MW, and turbines running at full capacity. Based on the results from that study, a sediment temperature of 11.6 °C is expected in 0.5 m sediment depth above a cable connecting five consecutive turbines with the transformer station. In case of emergency, the temperature could increase to up to 30 °C. Verification of these calculated data is required. First results of field measurements at Nysted offshore wind farm (Denmark, Baltic Sea) are expected to be published later this year, under the project "Measurements of Sediment Temperature in the Vicinity of 33 kV and 132 kV Power Cables at Nysted Offshore Wind Farm" (IfAÖ), funded by the BMU.

As discussed by ecologists (workshop discussion on "International Exchange of Experience on the Assessment of the Ecological Impacts of Offshore Wind Farms", Berlin May 2005), permanent temperature rise potentially leads to changes of physico-chemical conditions of sedimentary substrates, e.g. alteration of redox, O<sub>2</sub>, sulphide profiles, changes of nutrient profiles and increase in bacterial activity. During the discussion concerns were raised that effects may be most severe in areas with stratified or small water bodies, or in tidal areas during low tide at high ambient temperature. De-oxygenation of the seabed leading to death of a wide range of fauna is anticipated as the most obvious effect. Formation of "black spots" in the Wadden Sea might be facilitated along cable routes.

More subtle changes could also occur in the distribution of species. This issue is mainly discussed in connection with climate change, as a warming of air and seawater temperatures. Effects of climate change are certainly of different scale than effects caused by heat dissipation from power cables and results from such studies are not directly applicable to offshore wind farming. However, they may give clues on relevant impact-effect chains. HISCOCK ET AL. (2001, 2004) discuss the impacts and effects of climate change on subtidal and intertidal benthic species in Britain and Ireland. Coastal water of the British Isles became warmer during the 20<sup>th</sup> century and may rise a further 2 °C or more by the 2050s. The authors regard Britain and Ireland as well placed for the study of changes that might result from rising sea temperatures, since many northeast Atlantic continental-shelf species reach their southern or northern limits around these coasts. They conclude that populations of boreal-arctic species at the southern limits of their range will decline in abundance and could even disappear from the coastal waters of the British Isles and Ireland. If such species are characterising, dominant, or key structural or functional species in biotopes, then the biotope that they represent may also be changed, or even lost. The authors expect species at the northern limits of their range in Britain and Ireland to increase in abundance where they already occur, and

extend their distribution. Higher temperatures are expected to positively influence reproduction of such “southern species” by making it more likely or frequent, or by improving prospects for larval survival. And, by contrast to boreal-arctic species, if the species that increase in abundance are characterising or key structural or functional species in biotopes, then the biotope that they represent is likely to increase in geographical extent. HISCOCK ET AL. (2004) predict that changes will be most apparent in mobile species or benthic species with long-lived planktonic stages in their life histories. The authors also developed a key and decision tree for assessing the likely effects of seawater warming for particular species (Tab. 3). Factors determining the rate of geographical extension or reduction of distributional extent or change in the abundance of species at existing locations identified by the authors include e.g. mobility or dependence on larval dispersal, type of reproductive and dispersal mechanisms, population size, longevity of individuals, presence of suitable habitats for settlement, or presence of favourable currents.

Tab. 3 Key for assessing likely effects of seawater warming for a particular species (excerpt from Hiscock et al. 2004, text slightly abridged).

Key for determining likely effects of temperature increase on species		
1.	The species is pelagic (swims or drifts in the water column) The species is sedentary or sessile (attached to or crawling on the sea bed)	go to 2 go to 3
2.	The species is northern in distribution The species is southern in distribution	Type A Type D
3.	The species has a planktonic distributional phase The species has a benthic larva, very short-lived (a few hours) pelagic phase or reproduces asexually	go to 4 go to 5
4.	The species is long lived (>5yr) and likely to reproduce infrequently or not at all, at least at its geographical limits ('infrequently' means only every few years) The species is short-lived (<5yr) and currently reproduces frequently (usually once a year and over a prolonged period)	Type F go to 6
5.	The species currently reproduces infrequently or not at all, at least at its geographical limits ('infrequently' means only every few years) The species currently reproduces frequently (usually once a year and over a prolonged period)	go to 7 go to 8
6.	Species is northern in distribution Species is southern in distribution	Type C go to 9
7.	Species is northern in distribution Species is southern in distribution	Type B Type E
8.	Species is northern in distribution Species is southern in distribution	Type C Type E
9.	The species occurs in populations sufficiently dense or close so that gametes will meet The species occurs as isolated individuals and gametes are unlikely to meet, OR the species occurs at isolated locations or habitats where other suitable locations or habitats are likely to be too distant for propagules to reach	Type G Type E
<hr/>		
<i>Type A (northern volatiles)</i>		
Species that currently have a northern distribution, are pelagic or demersal (such as plankton and fish) and where the adults respond rapidly to temperature change. Significant changes will occur in relation to annual variations in temperature with an overall reduction in abundance and 'retreat' northwards over the next 50 yr.		
<i>Type B (northern stables)</i>		
Benthic species that currently have a northern distribution that will 'retreat' northwards, although very slowly, as the individuals are long lived and recruit irregularly. Reproductive success at current southern limits will be reduced as a result of higher temperatures. Decline in abundance at southern limits, but no significant change expected in distribution in the next 50 yr.		

*Type C (northern retreaters)*

Benthic species that currently have a northern distribution, are short lived (<5yr) and rely on regular recruitment from the plankton or from benthic larvae that will decline in abundance and 'retreat' northwards rapidly (in 'concert' with isothermal changes). The speed of change in abundance and distribution might fluctuate depending on the occurrence of particularly warm years. Significant reductions in abundance and distributional extent are to be expected in the next 50 yr.

*Type D (southern volatiles)*

Species that currently have a southern distribution, are pelagic or demersal (such as plankton and fish) and where the adults respond rapidly to temperature change. Significant changes will occur in relation to annual variations in temperature, with an overall expansion in distribution northwards and increase in abundance within their present limits over the next 50 yr. ...

*Type E (southern stables)*

Benthic species that currently have a predominantly southern distribution and which will expand northwards or become more abundant within their present range, but slowly. Individuals are long lived and reproduce infrequently by benthic or short-lived larvae or by asexual division. Reproductive success at current northern limits of distribution will improve as a result of higher temperatures. Abundance of individuals will increase at locations where they are already found. Northward extent will increase very little in the next 50 yr, and not at all where significant hydrographical or geographical barriers exist.

*Type F (southern gradual extenders)*

Benthic species that currently have a predominantly southern distribution and which will expand northwards and increase in abundance at their current locations and in a sporadic way dependent on particularly favourable years for reproduction. The species currently reproduce infrequently, at least at their geographical limits, but have a planktonic larva. There will be a 'lag' period between temperature increase and expansion in abundance or northern extent. ...

*Type G (southern rapid extenders)*

Benthic species that currently have a predominantly southern distribution and which will extend northwards at about the same rate as isothermal changes in sea or air temperatures, providing that currents are favourable and there are no barriers to spread. Species will become more abundant within their present range. ...

A publication by DE VOOYS (1990) investigates possible effects of a supposed rise in seawater temperatures on benthic ecosystems in coastal waters around the Netherlands. The present macrobenthic fauna in Dutch coastal waters is compared with bottom faunas of both the Seine and the Gironde estuaries. The mean yearly seawater temperature in the Seine estuary is about 2 °C higher than in the Marsdiep (Dutch Wadden Sea), that of the Gironde estuary nearly 4 °C higher. The author concludes that an increase in the mean water temperature of Dutch coastal waters by 2 °C or 4 °C may eventually result in an increase in the number of macrobenthos species by ~22 and ~30 %, respectively. Neither is Information given on the possible rate of dispersal of macrobenthos in a northern direction, nor is there any indication as to which species would vanish if an increase in mean coastal water temperatures were to occur.

The influence of a coastal power station thermal discharge on spatial variability of meiobenthic and macrobenthic community abundances in the Gulf of Follonica (Western Mediterranean) was investigated by LARDICCI ET AL. (1999). According to their results, assemblage structure and spatial distribution of the taxa studied was not influenced by heated effluents. At the same investigation site, a study of the structure of benthic communities was undertaken by CREMA & PAGLIAI (1980). The authors concluded that after about a year of operation, the heated effluent had brought about no alterations of the communities. WONG ET AL. (1998) investigated taxonomic composition and grazing impacts of calanoid copepods in coastal waters near nuclear power plants in northern Taiwan. There was no evidence to suggest that the slightly elevated surface water temperature had affected the community structure or grazing impact of calanoid

copepods. Also, KESER ET AL. (2003) found a decline in eelgrass (*Zostera marina* L.) in Long Island Sound near Millstone Point, Connecticut, USA, unrelated to thermal input from a nearby power plant.

These findings were contrary to those of other studies where effects of thermal discharges on benthic communities had been found. BAMBER & SPENCER (1984) undertook a sublittoral benthic study of a coastal power station thermal discharge canal. The Kingsnorth Power Station, on the River Medway Estuary, Kent, U.K., discharged cooling water into a canal comprising a 4 km creek system at the time of investigation. Sampling stations were selected along a gradation of thermal discharge influence. The authors found that the benthic fauna of the discharge system was modified by two aspects of the thermal regime, the tidal front effect, and to a lesser degree the gradient effect. The macrofauna was significantly suppressed at sites along the discharge canal, representing a community with a comparably small number of species and dense populations of a few dominant opportunistic species tolerant of thermal stress. Such species noted by the authors were *Tubificoides benedeni*, *T. amplivasatus* (Oligochaeta) and *Cauleriella zetlandica* (Polychaeta). SURESH ET AL. (1993) reported the death of almost all macrofauna and flora species during the hot season in an area impacted by the heated effluents from the Madras Atomic Power Station. KAILASAM & SIVAKAMI (2004) found negative effects of thermal effluent discharge on benthic fauna off Tuticorin Bay, on the southeastern coast of India. At the sampling station closest to the thermal effluent discharge site, only three benthic species were recorded. Dissolved oxygen content of the water was low. Temperature was negatively correlated with species diversity, benthos density and benthos biomass. VERLAQUE ET AL. (1981) studied the phytobenthos of rocky bottom near a thermal outfall at Martigues-Ponteau, Golfe de Fos, on the Mediterranean Sea. They found significant changes with increasing distance from the discharge and with increasing depth. Although was qualitative similarity, the quantitative composition of the algal community differed. SNOEIJIS (1991) states that especially macroscopic colony-forming diatom taxa respond strongly to artificially raised water temperature. In other cases, thermal discharges influenced the seasonal dynamics of benthic communities rather than the spatial distribution and the structure of assemblages (DINET ET AL. 1982). The results of the study on the influence of thermal effluents from a power plant on the benthic harpacticoid community near Marseille, France, revealed that seasonal variations decreased and a diversified harpacticoid fauna developed. ACHITUV & COOK (1984) discuss the possibility that thermal pollution from a nuclear power plant could be beneficial to *Palaemon pacificus*, a prawn inhabiting coastal waters of the South African Atlantic coast, based on the results of their studies on the influence of temperature on food consumption, growth, moulting rate and respiration.

### 5.3 Electromagnetic Fields

Another concern arising from offshore wind farm power cables is the occurrence of electromagnetic fields. As for the problem of heat emission into the sediment, not much information is available on the impacts of electric or magnetic fields near sea cables on benthic marine invertebrates.

There are different strategies for the technical implementation of grid connection. Factors affecting cabling strategy are parameters of installed power and distance to the coast (SÖKER ET AL. 2000). For small developments close to the coast connection to an on-shore grid can be realised by one or several medium voltage lines. This strategy was followed at the offshore wind farm Tunø Knob in Denmark, where 10 Vestas V39 500

kW wind turbines are connected to the grid by a 10 kV medium voltage submarine cable of 6 km length. With increasing transmission capacity and increasing distance high voltage systems become an option. Very common is transmission of electrical energy through underwater high voltage direct current (HVDC) lines (FOSTER & REPACHOLI, CAEM 2002). For example, all high voltage electric power cables across the Baltic Sea (e.g. Fenno-Skan, Gotland, SwePol Link, Baltic Cable, Kontek, Konti-Skan, Skagerrak) are HVDC lines. These systems can be monopolar or bipolar, depending on whether the return current is carried by seawater or a separate cable. Monopolar systems pass the current into seawater via electrodes, typically graphite anodes and titanium cathodes located on the seabed (KOOFS 2000). Examples for this kind of system include Fenno-Skan and Baltic Cable. More common are bipolar HVDC systems possessing bi-directional capacity. The alternative for the transmission of wind generated electricity from offshore wind farms to the mainland grid is high voltage three phase alternating current (AC) transmission. This system is often used if distances to shore are less than approx. 50 km (SÖKER ET AL. 2000). Although DC transmission suffers less line loss than a comparable AC line and also has additional advantages, the high costs of HVDC converters make the "break-even" distance, at which DC is more attractive than AC, rather long (CAEM 2002).

Apart from the cable link to shore, a wind farm internal grid, according to current plans and realisations of offshore wind farm developments, usually consisting of 33 kV AC lines, will be deployed. The function of inter-turbine cables is to collect the power from all the turbines and bring it to one or more "collection points" within the wind farm, from which it can be transmitted to shore (CMACS 2003).

The occurrence of electric and magnetic fields depends on the transmission system. With perfect shielding, a cable does not directly generate an electric field outside the cable, cables with non-perfect shielding allow the generation of electric fields outside the cable (KRAMER 2000, CMACS 2003). However, the directly generated electric fields are supposed to be smaller than the electric field induced by the presence of the magnetic field in the surroundings of the cable.

For a monopolar DC transmission system, the formation of electromagnetic fields during operation of the cable is expected (MATTHÄUS 1995). According to calculations for Baltic Cable (450 kV, 600 MW), weak electric fields (1  $\mu\text{V}/\text{cm}$ ) may occur at distances of up to 10 km from the electrodes. A direct current magnetic field occurs around the cable reaching up to 250  $\mu\text{T}$  directly above the cable, and decreasing to about 50  $\mu\text{T}$  at a distance of 6 m (corresponding to geomagnetic field strength of the earth). In addition, a magnetic alternating field may occur where sea cable and electrode cable run parallel. During high power transmission field strength is expected to reach 12  $\mu\text{T}$ , at a distance of 5 m it should be as low as 1  $\mu\text{T}$  (MATTHÄUS 1995). As reported by SÖKER ET AL. (2000) magnetic compasses show considerable deviations at the surface of the water directly above the Baltic Cable, forcing ship traffic to be informed about the cable to avoid wrong navigation.

For bipolar DC transmission systems, it is known that magnetic fields occurring in the surroundings of two cables with opposite currents can partially be compensated. The strength of the resulting magnetic field is defined by the distance between the cables. Hence, in regard to generation of electromagnetic fields, the shorter the distance between the cables, the stronger the compensation effect. But there are other aspects requiring consideration. For example, the risk of simultaneous cable damage decreases rapidly with increasing cable distance. For cables next to each other. the risk of damage of the two cables at the same time is 100 %, at a distance of 10 m it is only 33 % (KRAMER 2000).

The current state of knowledge regarding the electromagnetic fields emitted by AC transmission lines was summarised by CMACS (2003). For 132 kV three-phase submarine cables with perfect shielding it was reported that no directly generated electric fields occur outside the cable. Magnetic fields generated by the cable created 'induced' electric fields outside the cable. Modelling predicted electric fields in the water of around 25  $\mu\text{V}/\text{m}$  to be induced by magnetic fields observed during field trials (56 nT). The magnitude of the magnetic field in close vicinity to the cable (i.e. within millimetres) is about 1.6  $\mu\text{T}$  and will be superimposed on any other magnetic field (e.g. earth's geomagnetic field). The predicted levels are much higher for single-phase power cables (about 1000  $\mu\text{T}$ ).

Also, information on 33 kV XLEP cables carrying AC currents was obtained by CMACS (2003). AEI Cables Ltd., a company which designs and manufactures electric cables, provided calculations of the magnitudes of magnetic fields. These calculations yielded magnetic field strengths at 0 m and 2.5 m of 1.7  $\mu\text{T}$  and 0.61  $\mu\text{T}$ , respectively, for a current flow of 641 A.

Available information does not allow conclusive assessments of potential impacts and effects of electromagnetic fields on marine invertebrates. The recently published WHO fact sheet "Electromagnetic Fields and Public Health" (WHO 2005) concludes that "...none of the studies performed to date to assess the impact of undersea cables on migratory fish (e.g. salmon and eels) and all the relatively immobile fauna inhabiting the sea floor (e.g. molluscs), have found any substantial behavioural or biological impact." Survival rate and fitness in response to exposure to static magnetic fields of benthic animals common in the southern Baltic Sea were investigated by BOCHERT & ZETTLER (2004). The North Sea prawn *Crangon crangon*, the round crab *Rhithropanopeus harrisi*, the glacial relict isopod *Saduria entomon* and the blue mussel *Mytilus edulis* were exposed to static magnetic fields of 3.7 mT for several weeks under laboratory conditions. No significant differences between test and control groups were found.

Results of studies on the spiny lobster *Panulirus argus* from the West Atlantic Ocean revealed the possession of a magnetic compass sense (LOHMANN ET AL. 1995). Because inverting the vertical component of the earth's field had no effect on orientation under laboratory conditions, the results suggested that the lobster compass is based on field polarity, and thus differs from the inclination compasses of birds and sea turtles. The authors suggested the magnetic compass of lobsters to function in homing behaviour, in guiding autumn migration, or both. Other crustaceans known to possess magnetic compass sense are *Talitrus saltator* (ARENDSE 1978, SCARPINI & QUOCHI 1992), *Orchestia cavimana* (ARENDSE & BARENDREGT 1981), *Talorchestia martensii* (PARDI ET AL. 1985) and *Idotea baltica* (UGOLINI & PEZZANI 1992).

The nudibranch gastropod *Tritonia diomedea* inhabits subtidal waters of the northern Pacific Ocean. Laboratory experiments have demonstrated that the species can use the earth's magnetic field as an orientation cue (LOHMANN & WILLOWS 1987), while field studies have suggested that this sensory ability may help guide the specimens between offshore and inshore areas (WILLOWS 1999). Whether orientation of species using the earth's magnetic field as an orientation cue is affected by artificially generated electromagnetic fields in the vicinity of power cables is unknown.

WANG ET AL. (2003) report evidence of increased electrical activity of particular neurons in response to alterations of a magnetic field around specimens. FOSTER & REPACHOLI recognise a variety of mechanisms by which electric and magnetic fields can interact with biological structures. These include electrically or magnetically induced forces and torques on biological structures, and excitation and electrical breakdown of cell

membranes. Quantitative considerations suggest that these non-thermal mechanisms generally require very high field strengths (FOSTER 2000).

In summary, information available is not sufficient to make reasonable statements on possible effects of electromagnetic fields on benthic organisms. However, in regard to benthic marine invertebrates, such effects may only occur in close vicinity to the cables.

## **5.4 Disturbance**

Disturbance has been identified as one of the major impact factors in the course of offshore wind farm development. The term “disturbance” actually includes quite a number of different impact factors. Disturbance of the benthic community can occur either directly or indirectly. The latter applies to factors that primarily affect the marine environment, and thus secondarily affect the benthic community. Among direct effects on organisms are physical disturbance, damage, displacement and removal. Those effects mainly occur during the construction and decommissioning phases. as a result of activities related to site preparation, foundation installation, cable grid installation, or to decommissioning of the various wind farm components. Effects on the marine environment include all changes of biotope characteristics, e.g. changes of current and wave regimes or of sediment characteristics, loss of biotope structures, or introduction of new artificial biotope structures, sediment resuspension, at some sites together with redistribution of chemical contaminants. Such effects occur during construction and decommissioning but also during the operational phase.

### **5.4.1 Changes in Biotope Characteristics**

Potential changes of biotope characteristics discussed are most likely to result from alteration to current and wave climate and changes to the sediment regime due to the presence of wind farms. Generally is the distinction is made between local (i.e., near-field) effects and remote (i.e., remote-field) effects. Local effects occur in immediate vicinity of the wind turbine or within the wind farm area, whereas remote effects cover all changes in the area surrounding the development site, including adjacent coastlines (COOPER & BEIBOER 2002). Changes of biotope characteristics will be reflected in changes of composition and structure of the local benthic community. The area affected by the various kind of changes discussed in the following chapters is respective to the area exhibiting impacts on the local biota.

#### **5.4.1.1 Current and Wave Regime**

Based on a hydrodynamic-numerical model, MITTENDORF & ZIELKE (2002) investigated the effects on the current regime due to the presence of offshore wind farms in the Helgoland Bight. The magnitude of mean current velocity reduction in the wind farm area was site-specific but did not exceed 2.13 %. LEDER (2003) carried out studies on the influence of an offshore wind farm in the Arkona Basin of the Baltic Sea, on the current regime. The goal of the study was to answer the question as to whether the inflow of oxygen-rich water from the North Sea into the Bornholm Basin would be reduced by the presence of the wind farm. It was concluded that the degree of stratification of the water body would decrease locally in the vicinity of the turbines, but that the impact on the inflow situation into the Bornholm Basin was regarded as insignificant.

Potential effects of offshore wind developments on coastal processes related to British areas of interest were studied by COOPER & BEIBOER (2002). The authors examined effects under two scenarios: a “reasonable worst case” and a more “typical” facility. In conclusion, the results from generic tidal, wave and sediment modelling scenarios suggested that, at the regional level, there is unlikely to be a significant effect on coastal processes due to offshore wind farm development. The authors state that even impacts of the “reasonable worst case” should not lead to any major concern. Also they emphasise predicted changes in each coastal parameter to be at the limit of accuracy of conventional monitoring equipment. However, in a report by BMT Cordah Ltd., the author raises the concern that it is presently not possible to draw firm conclusions about changes in flow regime, wave climate, sandbank mobility and coastal sediment budgets from these studies, unless only small scale wind farms, similar to those of the Round One sites (U.K.) considered (BAKER 2003).

#### **5.4.1.2 Disturbance of the Seabed**

Installation of turbine foundations and cable connections represents a disturbance of the seabed, the habitat of benthic organisms. The extent of the impacted area will be determined by the area of direct habitat loss (e.g. depending on diameter of turbine support structure), and the area changed in regard to factors effecting benthic colonisation (area affected by scour, changes of current regime, changes of sediment parameters or redistribution of contaminants etc.).

##### *DIRECT HABITAT LOSS*

The turbine support base diameter depends on the foundation type. Base diameters of monopiles range from 3 to 3.5 m, those of tripods from 10 to 12 m, and of gravity foundations from 12 to 15 m (OWEN 2000). COOPER & BEIBOER (2002) report that with increasing turbine capacity to 3 and 3.5 MW base diameters of monopiles is expected to increase to about 5 m and that of gravity foundations to up to 15 m. The literature suggests a trend towards selection of monopile foundations. However, the footprint of foundation using either monopiles or gravity foundations will represent only a small fraction of the sea area occupied by a wind farm (e.g. SÖKER ET AL. 2000). Thus the direct loss of physical seabed habitat during the operational phase of a wind farm is regarded as minimal. The same applies to seabed cable infrastructure.

##### *SCOUR*

The problem of locally generated scour is under intensive discussion. The important question is whether it is possible to quantify scour around offshore structures. A methodology is required which takes data on the design of the structure, the environmental forces (waves, currents, etc.) and the soil characteristics, and converts them to an estimate of scouring (WHITEHOUSE 1998). Existing models for calculation of scour do not fully cover conditions in the marine environment (UNGRUH & ZIELKE 2003). The time-varying nature of the waves and currents makes the problem considerably more complex, compared to more or less unidirectional flow systems like rivers. Available information on scour in the marine environment is, at the present, mainly based on small-scale models of monopile support structures, but efforts have been made to enhance knowledge of scour. For example, the research project GIGAWIND supported by the German Federal Ministry of Economics and Technology



(Bundesministerium für Wirtschaft und Technologie) has addressed various technical aspects of offshore wind energy converters, including a model-based quantification of scour. The goal of the research project SCARCOST (Scour Around Coastal Structures) funded by the European Union within the framework of the MAST III (Marine Science and Technology) programme was “...to study the potential risk for scour in the vicinity of coastal structures, and to prepare and disseminate practical guidelines, to be developed from the research programme and also taking into account all ‘state-of-the-art’ knowledge (<http://vb.mek.dtu.dk/research/scarcost/scarcost1.html>). The project included theoretical studies, laboratory experiments and also field studies. The work of the participants in the project resulted in a number of publications providing new mathematical models for prediction of scour (e.g. WHITEHOUSE 1998, SUMER & FREDSE 1998, 2001, SUMER ET AL. 2001). The complete list of SCARCOST publications can be viewed on the project website:

(<http://www.isva.dtu.dk/research/scarcost/Public/MASTpubl.htm>).

Scour results from locally modified flow regimes leading to changes of the local sediment transport capacity (COOPER & BEIBOER 2002). Generally, the distinction is made between local scour and general scour. General scour acts over larger areas and longer time scales, whereas local scour results from the immediate impacts of a structure.

The development of scour is influenced by the dimensions, shape and spacing of piles, by sediment size and specific density, by tidal flows, water depth and wave regime (COOPER & BEIBOER 2002). Examples for estimation and observation of scour development are available for a limited number of offshore constructions. For the Horns Rev offshore wind farm in Denmark, it was estimated that using a 4 m diameter steel monopile would lead to a maximum scour depth of 6.7 m (1.9D) at defined preconditions. Observations of scour were undertaken for Christchurch Bay Tower, U.K. The pile diameter was 2.8 m with a gravity base of 10.5 m diameter. Scour occurred at 0.5 to 1 m around the periphery of the base, extending a distance of between 12 and 20 m from the base (COOPER & BEIBOER 2002). According to METOC Plc (2000), the area around a structure prone to local scour is usually expected to be approximately ten times the diameter of the structure. BAKER (2003) reports the extent of scour to be between 24 and 50 m for monopile foundations of 4-5 m in diameter. The distance between the turbines in a wind farm area makes it unlikely that the so-called “wake” effects generated by each pile will interact with each other. The extent of scour can be reduced by placing scour protection at the base of the foundations. Typically, scour protection materials are placed around a tower having a radius of 25 m (BAKER 2003). BAKER (2003) also attempts to calculate the areas of impact, and finds that the percentage of area scoured at both 1000 m and 700 m spacing is less than 0.1 % of the overall wind farm area. The impact of scour is concluded to be localised, and hence the impact is considered low.

Scour pits are described by HISCOCK ET AL. (2002) as areas where fine sediments are removed, leaving large shells and coarse sediment often colonised by fast-growing species such as tube-worms and barnacles. The scour pits are reported to attract some mobile seabed species and crabs and lobster together with fish. KNUST ET AL. (2003) raise the issue of the establishment of benthic communities atypical for the undisturbed area and different from the resident communities. Such local changes of the benthic community structure and composition due to the presence of wind turbines could also bring changes in the surrounding infaunal community (see Chapter 5.4.3; CRIPPS & ABEL 2002).

## CONTAMINATION

If sediments have historically been used for industrial, sewage or ammunition disposal, or acted as a natural sink for oil or chemical contamination, there is a potential that these substances, with the accumulated contaminants, will be redistributed (BAKER 2003). GOLDBERG & BERTINE (2000) report the apparent pauperisation of natural fauna in San Diego Bay due to the large number of socially, industrially and agriculturally introduced chemicals. SOTO ET AL. investigated changes in biometry and shell weight of the mussel *Mytilus galloprovincialis* on exposure to metals. The effects of clean and Zn-polluted environments and the exposure of Zn-polluted mussels to sublethal concentrations of Zn, Cu and Cd were studied. Zn-polluted mussel shell weights increased significantly after a 51-day depuration period, whereas exposure to Zn or Cd caused a slightly reduced shell growth, while with depurating mussels, Cu-exposures did not cause any reduction in growth. USSENKOW (1997) studied contamination of harbour sediments in the eastern Gulf of Finland (Neva Bay), in the Baltic Sea. The conclusion was that all investigated harbours showed significant sediment contamination due to industrial discharges. Deposits in the port of Kronstadt contained particularly high concentrations of oil products and Hg, Pb, and Cu. Species composition and biomass analyses were also conducted at this site for the macrozoobenthos. The biomass of Chironomidae was found to be the best indicator for sediment contamination (inverse correlation). The total biomass of macrobenthos as well as the biomass of Oligochaeta were not regarded as informative indicators.

Contamination of sediments is also known from areas where oil platforms have been established. As is known from the U.K. or the Netherlands, oil and gas industrial areas (drilling/exploration sites, platforms) and proposed offshore wind farm areas are not too far from each other (see <http://www.windopzee.nl/kaart.asp> for the Netherlands or [http://www.og.dti.gov.uk/upstream/licensing/23\\_rnd/23\\_wfla.pdf](http://www.og.dti.gov.uk/upstream/licensing/23_rnd/23_wfla.pdf) for the U.K.). Many oil platforms have large piles of cuttings lying beneath them, which probably present the greatest potential hazard to the environment (GRANT & BRIGGS 2002, KINGSTON 1992). There is also increasing evidence to suggest that for areas of intensive drilling or production activity, there has been a significant rise in hydrocarbon levels in the sediment at distances between 5 and 10 km from installations (KINGSTON 1992). OLSGARD & GRAY (1995), studying contamination of sediments in areas of offshore oil and gas exploration on the Norwegian shelf, report that after a period of six to nine years contamination, had spread to areas 6 km away from the platform.

Adverse ecological impacts of discharges from oil and gas platforms on the benthos of the adjacent sea floor are well known. The strongest effects on zoobenthic communities can be observed at locations where oil-based drilling muds are discharged. In general, in worst affected areas, the fauna is of low diversity and dominated by opportunistic species. KINGSTON (1992) gives a distance of 2000 m for attaining preoperational levels of species richness. The author also reports that low abundances of macrozoobenthic species in the vicinity of platforms represents the typical phenology. Further away, faunal diversity may be similar, but with a detectably different species composition (GRANT & BRIGGS 2002). Multivariate methods indicated changes in faunal composition within a 2-3 km radius from Ekofisk and 1.5 km from Eldfisk oilfields in the North Sea (GRAY ET AL. 1990). According to OLSGARD & GRAY (1995), analysis of the initial effects on the benthic fauna showed that there were no consistent patterns in changes in species composition over fields or time, and thus the authors suggest the search for universally sensitive indicator species does not seem to be rewarding. However, under gross effects of pollution, they found consistent patterns with the same species dominating.

DAAN ET AL. (1994) and DAAN & MULDER (1996) published results of a research programme on the effects of drill-cutting discharges on the benthic communities around platforms on the Dutch continental shelf. Elevated total hydrocarbon concentrations in the sediment occurred up to 750 - 1000 m from well sites during the first year after discharges had stopped. Though concentrations tended to decrease during the following years, they remained far higher than natural background levels, even after eight years, within a few hundred meters from the platform. Biological effects were detectable at distances of up to  $\geq 1000$  m. A few very sensitive species, particularly *Echinocardium cordatum*, *Harpinia antennaria* and *Montacuta ferruginosa*, showed reduced abundances. Closer to the well sites, increasing numbers of species experienced adverse effects. After eight years, the macrofauna was still affected at distances  $\leq 500$  m.

GRANT & BRIGGS (2002) report data on the toxicity of sediments from around the North West Hutton platform to the amphipod *Corophium volutator* and the polychaete *Arenicola marina*. Sediment was acutely toxic to *C. volutator* out as far as 600 m from the platform. A 10 % dilution of contaminated sediment from 100 m from the platform with clean sediment inhibited *Arenicola* feeding almost completely. GÓMEZ GESTEIRA & DAUVIN (2000) identified amphipods of the genus *Ampelisca* to be good indicators of the impacts of oil spill on soft bottom communities in the western English Channel and off the north-western Iberian peninsula.

CRANFORD ET AL. (1999) exposed adult sea scallops from Georges Bank, *Placopecten magellanicus*, to different types and concentrations of operational drilling fluids and their major constituents under laboratory conditions. Chronic exposure to oil-based drillings muds caused high mortalities at concentrations as low as 1.0 mg/l. Also effects on growth and reproductive success could be documented in this study.

DAAN & MULDER (1996) also investigated discharge sites of water-based drilling muds. Biological surveys were carried out within two months to one year after discharges were terminated. Adverse effects on the benthic community were not detected, even within the immediate vicinity (25 m) of the discharge site.

For further information on the environmental impacts of offshore oil and gas developments see <http://www.offshore-environment.com/description.html>.

#### 5.4.1.3 Habitat Destruction

If excavated sediment is deposited on the seabed, changes in the morphology of the area and changes to the substrate available to marine organisms could result (METOC Plc 2000). SÖKER ET AL. (2000) estimate that cable laying may disturb a two meter wide sector on the ground on both sides, and water will be disturbed some meters around the construction site. The same authors expect the effect on water to be diminished after some hours, whereas effects on the sea floor will be observable for some weeks. At the Nysted offshore wind farm in Denmark, a backhoe was used to excavate a 1.3 m wide, 1.3 m deep and 10,300 m long cable trench. Excavation work took one month (BIRKLUND 2003). The excavated sediment was placed alongside the trench and later used for the back filling which took place in January and February 2003. The total volume of seabed material excavated was approximately 17,000 m<sup>3</sup>. The sediment spill was estimated to be 0.5 – 1 % of the amount excavated. Inspection of the trench after the back filling showed that the surface of the trench was below the surrounding seabed, due to inadequate filling of the trench. In addition, the lowered seabed acted as a trap, and the trench was filled with detached macrophytes.

Monitoring accompanying the cable laying revealed that shoot density of eelgrass and the biomass of rhizomes were reduced close to the trench as a combined effect of sediment spill during excavation and back filling and temporary burial below sediment deposited alongside the cable trench. Change in the overall composition of the surface sediment was not detected. However, at some stations close to the trench, the silt/clay content of the sediment was higher after the earthwork and this increase was probably caused by local sedimentation of fine sediment spilled during dredging and back filling. The structure of the benthic fauna had changed significantly at the impact stations close to the trench. Whereas the abundance of the benthic fauna was reduced by 10 % at the control stations, abundance at the impacted stations decreased to 50 %. According to the author, all effects were confined to a narrow zone close to the cable trench (BIRKLUND 2003). Fast recovery of the benthic community was expected at the stations close to the cable trench. Within the trench, the accumulation of macroalgae was assumed to delay or prevent re-colonisation of the sediment by the local fauna. However, in regard to the area affected, the impact on the offshore environment was considered negligible.

Habitat destruction is anticipated to be most severe when biogenic habitat structures like mussel beds, *Sabellaria* reefs or maerl beds are affected. HALL-SPENCER & MOORE (2000) have published an article on the impacts of scallop dredging on maerl habitats. "Maerl" is a collective term for several species of calcified red seaweed. Maerl beds are mixed sediments built by a surface layer of slow-growing, unattached coralline algae, creating a habitat for rich fauna. Results of the study showed a 70 % reduction of life maerl in a formerly unfished maerl bed after scallop dredging, with no sign of recovery in the subsequent four years. The high sensitivity of maerl beds is explained by the slow growth and poor recruitment of maerl species. Sabellarian reefs (*Sabellaria spinulosa*) are considered to be less prone to destruction by physical damage (e.g. due to shrimp fishery gear). Provided that the worms are not killed or removed from their tubes, the natural growth and capacity for repair is such that they can rebuild destroyed parts of their dwellings within a few days (GRUET 1971 in VORBERG 2000).

Discussion of destruction of biogenic habitat structures might in any case be of low relevance in connection with offshore wind farm developments. Most likely such areas fall under protection of the EC Habitat Directive, as Special Areas of Conservation. In such cases, wind farm development would be precluded.

#### **5.4.2 Physical Disturbance and Damage to Benthic Organisms**

Installation of foundations (piling, seabed preparation and other activities) may cloud the water around the site of construction activities. Comparable effects must be expected when removing the foundations after service life (SÖKER ET AL. 2000). The area affected by plumes and smothering depends on the amount of excavated and dumped sediment, on the depth of the seabed, and the dispersal in the water column; finer particulates remain in suspension longer than larger particulates and can potentially disperse over a wider area (HISCOCK ET AL. 2002). For a wind farm development site in Great Britain, the Inner Dowsing offshore wind farm (Greater Wash Strategic Area), it has been predicted that 90 % of resuspended sediments from cable laying has settled out within 1 km of the construction corridor (OFFSHORE WIND POWER LTD. 2002 in BAKER 2003). The amount of resuspended material was regarded as insignificant in comparison with baseline conditions. As pointed out by BAKER (2003), the relative impact of sediment redistribution will be controlled by the amount of redistribution (the thickness of the layer of resettled sediment), its variance from the existing material (introduction of mud onto a

sand sediment is expected to have a more substantial effect than mud settling on mud), and the sensitivity of the species or community. Benthic fauna and flora in a wider range will be covered with mud and sand (SÖKER ET AL. 2000). Their mechanisms of filtration will be at least temporarily obstructed. Possible turbidity of the seawater could affect the growth of the macrobenthos for a certain period. Coverage with soil may have a lethal effect on some macrobenthos species.

ANDRULEWICZ ET AL. (2003) published an article on the environmental effects of the installation and functioning of the submarine *SwePol*/Link HVDC transmission line in the Polish area of the Baltic Sea. One part of the study included investigations of the bottom macrofauna in regard to mechanical disturbances due to cable installation. Significant changes in zoobenthic species composition, abundance or biomass which could have been clearly related to cable installation were not observed. Contrary findings were arrived at by KNUST (1997): Benthic studies accompanying the construction of the EUROPIPE gas pipeline in the German Wadden Sea from 1993-1995 revealed effects on benthic organisms during the construction phase.

KÖNNECKER (1977), in an article on epibenthic assemblages as indicators of environmental conditions, presumes that water turbidity and sediment precipitation exert a major control on epifaunal distribution patterns, especially in organisms particularly prone to clogging of their incurrent canals. The author reports tunicates to be immune to sedimentation, whilst hydroids and bryozoans seem to be able to cope. MAURER ET AL. (1986) reported that epifaunal or deep-burrowing siphonate suspension feeders were unable to escape burial by more than 1 cm of sediment, whereas infaunal non-siphonate feeders tolerated burial by 5 cm, but less than 10 cm (in HISCOCK ET AL. 2002). According to the author, many species are adapted to burrowing through specific types of sediment; hence effects were worsened if the sediment differed from their native sediment.

There are quite a number of articles which investigate the physical disturbance of benthic organisms and communities due to fishing activity. Conclusions from these studies seem relevant for assessment of possible impacts on benthic organisms due to physical disturbance during construction activity at wind farm development sites. FRID ET AL. (2000) reported significant differences in benthic communities of selected fishing grounds in the North Sea between the early 1920s and the late 1980s. These differences were found to be the result of changes in abundance of many taxa rather than large-scale losses of sensitive organisms. Reduced abundances in the field attributed to high frequencies of disturbance may be explained by direct mortality of organisms, mortality due to destruction of tubes and exposure to predators, relocation of species and loss of individuals from the increasingly unstable sediment via water currents (COWIE ET AL. 2000).

BRADSHAW ET AL. (2002) investigated long-term changes in Irish Sea benthic communities in relation to disturbance caused by scallop-dredging. The authors state that species are most likely to survive physical disturbance which a) are able to avoid damage (e.g. by swimming out of the way or burrowing deep into the sediment); b) are able to physically withstand impact (either by having a robust body or protective shell, or by being able to repair or regenerate damaged parts); or c) have life-history characteristics that enable rapid colonisation of empty spaces, an extended reproductive season or high fecundity to ensure a large supply of young. On the other hand sessile and fragile species with poor abilities of regeneration are likely to be affected or even eradicated from the area of disturbance (Tab. 4). Taxa regarded sensitive towards disturbance in the Irish Sea are: the brittlestars *Ophiotrix fragilis* and *Ophiopholis aculeata*, the hydroids *Lafoe dumosa*, *Sertularella* spp. and

Campanulariidae, the bryozoans *Crisia* spp. and *Scrupocellaria* spp., and several incrusting calcareous species like serpulids and spirobid worms (Polychaeta), and of barnacles and encrusting bryozoans.

Tab. 4 Scoring of benthic taxa according to their life history in regard to sensitivity towards scallop-dredge disturbance (from BRADSHAW ET AL. 2002).

Criteria used in scoring animal life histories			
Characteristic	Score		
	1	2	3
mobility	sessile	slow moving	very mobile
habitat	shallow burrower/nest builder	surface dweller	deep burrower
dominant feeding method	suspension/filter feeder	deposit feeder/grazer	scavenger
preferred Sediment	shell/stones	sand/gravel	mud/sand
fragility	fragile	intermediate	robust
powers of regeneration/recolonisation	poor	intermediate	good

High scores indicate characteristics that would theoretically be advantageous to surviving dredge disturbance, low scores those that would make them vulnerable.

BERGMAN & VON SANTBRINK (2000) investigated mortality in megafaunal benthic populations caused by trawl fisheries on the Dutch continental shelf in the North Sea. Regarding the sensitivity of different species towards physical disturbance, they found most of the larger-sized robust species or species able to burrow deep into the sediment to be more resistant. Such species included the sea star *Astropecten irregularis*, the brittle star *Ophiura textura* and the bivalves *Chamelea gallina*, *Corbula gibba* and *Ensis* spp. Species most sensitive either populated the uppermost sediment layer or are fragile. As sensitive species identified included the sea urchin *Echinocardium cordatum* and the bivalves *Phaxas pellucidus*, *Mactra corallina* and *Spisula* spp. Among Baltic Sea species, the genera *Corbula* and *Astarte* are considered to possess high mechanical resistance (RUMOHR & KROST 1991).

Other species may benefit from fishing activity. RUMOHR & KUJAWSKI (2000), comparing historical and recent data, found an increase in the frequency of occurrence of scavenging and predatory species (crustaceans, gastropods, sea stars). The authors attributed this observation to the large amounts of discards and moribund benthos generated by trawling. The goal of a study by GROENEWOLD & FONDS (2000) was to identify epibenthic species which showed scavenging behaviour, and to detect their food preferences. The decapods *Liocarcinus holsatus* and *Pagurus bernhardus* as well as the sea star *Asterias rubens*, ophiurids, and small gadoids were the main active scavengers feeding on different kinds of food, while lysianid amphipods (*Orchomene nanus*, *Scopelocheirus hopei*) fed mainly on crustacean carrion. It is estimated that after a single beam trawl, 6% to 13% of the annual secondary production of macrozoobenthos per unit area would suddenly become available to scavengers and to the detritus food chain.

Other publications with reviews of the long and short-term effects of bottom fisheries on benthic invertebrates include PHILLIPPART (1989), ELEFThERIOU (2000), LINDEBOOM (1995), BALL ET AL. (2000) and MORTON (1996). The majority of studies considered alteration of benthic communities due to disturbance. One investigation not revealing long-term effects of mussel dredging on the distribution of fish and epibenthic invertebrates was by HOFFMANN & DOLMER (2000). FRID ET AL. (1999) compared benthic communities of *Nephrops norvegicus* fishing grounds and benthic communities outside fishing areas off the northeast coast of England. At this heavily fished station, the

increase in fishing activity did not alter the abundance of taxa predicted to decline. The authors impute this observation to the long history of fishing at the site already having caused declines in sensitive taxa.

BONSDORFF ET AL. (1995) tested in a set of field and laboratory experiments the impact of combined biotic and physical (environmental) mechanisms on the organisation of zoobenthic communities. In an aquarium experiment, the authors found that although direct predation by the isopod *Saduria entomon* or physical sediment disturbance alone had little effects on juvenile (< 3 mm) *Macoma balthica*, the combined effects of these factors were significant, and more important than the sum of the two single factors, demonstrating synergistic negative effects.

The recovery of a community from a localised disturbance event will depend on its original composition and the species pool present on a regional scale (COWIE ET AL. 2000). BOSSELMANN (1988) presents the results of a colonisation experiment conducted in a subtidal area of the North Sea. The study site was the research platform Nordsee located in the Helgoland Bight at about 25 m water depth. Substrate containers were held in position by a crane on the base of the platform 6 m above the seafloor, and the settlement and succession of benthic animals in the containers was followed over a period of about 1.5 years. A large seasonal and annual variability of settlement and early succession was observed, with the greatest potential for colonisation in spring and summer. A preliminary stabilisation of the community was reached after eight months. Succession up to the stage of a mature benthic community could not be observed during the course of the 1.5 year-long study. KENNY & REES (1996) investigated recolonisation of a marine gravel extraction site off North Norfolk (U.K.). Results indicated that whilst the dominant species recolonised quickly, many rarer species did not. The authors emphasise that the presence of certain k-selected species (like *Modiolus modiolus* and *Flustra* sp.) may be required to "condition" the environment before the full range of species which were present before aggregate extraction can again become fully established. During benthic studies accompanying the construction of the EUROPIPE gas pipeline in the German Wadden Sea from 1993-1995, conditions approximated those prior to construction activity after two years (KNUST 1997). Full recovery of the benthic community was gained here after about two to three years. METOC PLC (2000) reported that recolonisation after anthropogenic disturbance may take three to five years, provided seabed substrate is not contaminated and that it does not differ substantially before and after disturbance.

GÜNTHER (1992) investigated dispersal modes of benthic organisms contributing to the recovery of disturbed areas. She concluded that settlement of planktonic larvae predominates if the disturbed area is large. In smaller affected plots, postlarval transport as well as immigration of adults plays a more significant role. LU & WU (2000), in a study from Hong Kong, concluded that recolonisation of defaunated sediments was predominantly contributed by larval settlement rather than adult migration. By contrast, at an intertidal site in upper Old Tampa Bay, Florida, adult dispersal was shown to be a significant factor in the establishment of benthic populations (DAUER & SIMON 1976). Larval settlement was regarded as being more significant for the maintenance of populations. According to SMITH & BRUMSICKLE (1989), interaction occurs between dispersal mode, patch size, and colonisation rate for nonsessile macrofauna with planktonic larvae. They concluded that postlarval immigration may be a major mode of colonisation in soft bottoms generally. BONSDORFF (1983) found recovery potential of benthic communities in a shallow brackish water environment to be high. Some polychaetes (e.g. *Nereis diversicolor*) were found to colonise a defaunated area rapidly by active adult immigration, whereas others (e.g. *Manayunkia aestuarina*) are slow

colonisers, due to their entirely tubicolous life cycle. Bivalves are expected to mainly colonise by settling larvae, and migrations among the post-settled. The author found that the crustaceans *Corophium volutator* and *Bathyporeia pilosa* showed opportunistic behaviour.

In conclusion, the literature indicates that a general idea as to response by different species to physical disturbance and damage exists. Special attention should be paid if endangered species inhabit a proposed development area. Recolonisation of areas heavily affected or defaunated in the course of wind farm construction/installation will occur. However, full recovery of the site might take up to several years.

#### 5.4.3 Introduction of New Faunal Components and “Reef Effects”

Introduction of artificial hard bottoms along with the so-called “reef effect” was believed to have the greatest impact on ecosystem levels in a recently published study reviewing processes taking place in the course of wind farm development (BIOWIND 2005). Also HISCOCK ET AL. (2002) see the wind farm structures themselves and any scour protection that is introduced as likely to create the greatest changes to the communities and species present in an area. Several studies have been undertaken to follow and document the succession of epibenthic colonisation on artificial hard bottoms in the marine environment. HISCOCK ET AL. (2002) describe marine growth on structures closer than 10 km to the coast of the British Isles as typically commencing with colonisation by species that produce large numbers of planktonic larvae for extended periods and are fast growing once settled. In intertidal areas, the authors expect species like *Porphyra* spp., barnacles (*Semibalanus balanoides*) and mussels (*Mytilus edulis*) to be among the first colonisers. In subtidal areas, such species could be the tubeworm *Pomatoceros triqueter* and the barnacle *Balanus crenatus*. Green algae like *Enteromorpha* sp. and *Ulva lactuca* are also expected to grow on the artificial surfaces. Where sand is in suspension, the establishment of the rosette worm *Sabellaria spinulosa* is possible. In a second step, about a year after initial colonisation, solitary sea squirts (*Asciidiella* spp.), barnacles (*Balanus crenatus* and *B. balanus*) and mussels (*Mytilus edulis*) may overgrow the first colonisers. The establishment of a rich community of “soft” fouling organisms might be observed within a period of about three years. Species belonging to such a fouling community in shallow areas may include a variety of red algae and kelp species; in deeper waters hydroids (e.g. *Tubularia* spp., *Obelia* spp.), anemones (e.g. *Metridium senile*, *Sagartia elegans*, *Actinothoe sphyrodeta*, *Alcyonium digitatum*), bryozoans (e.g. *Bugula* sp.), feather stars (e.g. *Antedon bifida*), sea squirts (e.g. *Asciidiella* spp., *Ciona intestinalis*, *Clavelina lepadiformis*, *Botryllus schlosseri* etc.) and various sponges (e.g. *Esperiopsis fucorum*). Another scenario anticipated by the authors is the coverage of the artificial hard bottom by tube-building jassid amphipods *Parajassa pelagica* or *Jassa falcata* (HISCOCK ET AL. 2002).

The fouling community on turbine towers and scour protection was investigated as part of the monitoring programme at Horns Rev wind farm on the North Sea coast of Denmark. The latest results are from May and September 2004, approximately two years after construction of the wind farm (LEONHARD & PEDERSEN 2005). A total of seventy invertebrate taxa was reported. The amphipods *Jassa marmorata* and *Caprella linearis* clearly dominated the epifouling community at water depths, just beneath the surface, and at the sea floor. Abundances of > 650,000 ind./m<sup>2</sup> and > 90,000 ind./m<sup>2</sup>, respectively, were recorded in September 2004. Regarding other species occurring on the piles a distinct vertical zonation was observed. The splash zone was almost exclusively populated by the giant midge *Telmatogeton japonicus*. Just beneath the



surface, larger individuals of *Mytilus edulis* were attached to the piles. Starting about 1 m beneath the surface, individuals of *Cancer pagurus* were frequently found on the piles (300 to >900 Indl/m<sup>2</sup>). The barnacle *Balanus crenatus* reached its highest abundance levels at depths of 3 to 5 m. The calcareous bristle worm *Pomatoceros triqueter* was also more abundant in the lower zone than in the upper zone on the monopiles. The starfish *Asterias rubens* was identified as the key predator controlling the vertical and horizontal distribution of its prey species. Sea anemones (*Metridium senile*, *Sargartia elegans*, *Sargartiogeton laceratus*) were found in each depth zone in relatively high coverage and numbers. More mobile species like the common whelk *Buccinum undatum*, the netted dog whelk *Hinia pygmaea*, the common shore crab *Carcinus maenas* as well as the long clawed porcelain crab *Pisidia longicornis* were occasionally found on the monopiles. Taxa most abundant on the monopiles were congruent with those most abundant on the scour protection (LEONHARD & PEDERSEN 2005). Horizontal zonation was found in the communities inhabiting the scour protection area. One distinct zone covered the distance from the monopiles to 10 m from the turbines, the second zone extended from 6 m to 12 m, and a third zone from 10 m to 16 m from the monopile. The coverage and frequency of *Jassa marmorata* decreased towards the edge of the scour protection. The polychaete *Lanice conchilega* and the hermit crab *Eupagurus bernhardus* were more commonly recorded at greater distances from the turbines. Other typical epifaunal species such as *Pomatoceros triqueter* and the slipper limpet *Crepidula fornicata* showed a more even distribution throughout the zones. Various algae were also found on the monopiles and the scour protection. Microscopic green algae and diatoms coated the splash zone on the piles. Just beneath the surface, down to about 2 m, seaweed species of the genus *Petalonia* and the brown algae *Ectocarpus* sp. were recorded. In greater depths on the piles and also on the scour protection *Enteromorpha* spp. occurred.

Initial colonisation at the FINO 1 platform in the German Bight was by Hydrozoa and Bryozoa (JOSCHKO ET AL. 2004). After four to six weeks, an amphipod species and anemones started to colonise the artificial hard bottom and at the same time abundance of the early colonisers began to decrease. After about eight months, the tube-building amphipods covered the piles densely. SCHROEDER (1995) investigated the epifauna of a sunken oil platform in about 43 m water depth in the German Bight. Because of the size of the structure, the uppermost parts of the platform reached up to about 13 m water depth. SCHROEDER (1995) found the top of the platform almost completely covered by *Metridium senile* and *Alcyonium digitatum*. The occurrence of echinoderms such as *Asterias rubens*, *Psammechinus miliaris* and *Echinus esculentus* was also reported. With increasing depth, sponges and the polychaete *Pomatoceros triqueter* became more abundant. Starting at 30 m depth, the fauna consisted almost exclusively of *P. triqueter* and Echinoidea. Parts of the platform supposedly treated with antifouling paint did not show a generally different species composition, but the density of settling organisms was considerably reduced. At Poole Bay Artificial Reef, installed in 1989 off Dorset, U.K., the initial barnacle and serpulid polychaete dominated community developed into an ascidian-polyzoan turf on the slab bases and into an algal-hydroid turf at the tops (HATCHER 1998). The number of species as well as the biomass was greater on the slab bases than the tops. Encrusting bryozoans, ascidians and hydroids were generally better competitors for space than were serpulids and barnacles. Porcelain crabs (Porcellanidae) and scale worms (Polynoidae) constituted the major share of the mobile invertebrate community. Results of studies from the Yttre Stengrund and Utgrunden wind farms in Sweden (Baltic Sea), undertaken in 2003, report on two layers of filtrating organisms covering the turbine towers. barnacles (*Balanus improvisus*) were identified as the primary colonisers. They were covered by a layer of loosely attached

blue mussels (*Mytilus edulis*). Comparison of body size revealed that mussels collected from the piles were considerably larger than specimens collected from the bottom around the piles.

Surveys of sessile and mobile invertebrates and attached macroalgae on turbine foundations and scour protection were conducted at Nysted offshore wind farm (Denmark, Baltic Sea). Installation of the turbines and foundation structures started in 2002. In October 2003, the zone just beneath the water surface was dominated by barnacles (BIRKLUND & PETERSEN 2004). A dense layer of blue mussels (*Mytilus edulis*) covered the shafts (the vertical cylindrical and smooth concrete surfaces of the foundations). The specimens were of small size with shell lengths < 10 mm. Bivalves were growing on top of barnacles (*Balanus improvisus*), supposedly the initial colonisers of the artificial hard bottom at Nysted. With increasing depth, mobile species such as *Corophium insidiosum* and *Microdeutopus* sp. occurred more frequently. The authors suggested that a reduction in wave action and a simultaneous increase of macroalgae and deposit of silt may have contributed to the observed changes. The scour protection (stones) was reported to be covered by macroalgae by up to 50 % or more. Brown algae dominated, while red algae were of larger size; green algae were scarce. A few shrimp (*Palaemon elegans*) were observed in tufts of macroalgae. The crab *Carcinus maenas* was common on the scour protection, and more specimens were assumed to be hiding in the mosaic of stones.

Differences in the sessile biota among five artificial reefs located off South Carolina and Georgia in 22 – 31 m depth were related to the proximity of natural hard-bottom habitat, and to the possible treatment of the surfaces with antifouling paint (WENDT ET AL. 1989). WENNER ET AL. (1983), investigating hard bottom habitats in the South Atlantic Bight, reported species composition to noticeably change with depth and season. WOODHEAD & JACOBSON (1985), carrying out comparative studies on both artificial coal waste and concrete reefs, found that concrete tended to be overgrown more quickly, although both materials appeared suitable substrates for development and growth of epifaunal communities. BUCKLEY & HUECKEL (1985) reported an increasing algal and invertebrate species diversity following starfish and nudibranch predation of the space domination barnacles at an artificial reef in Puget Sound, Washington. Algae colonisation was observed as a major contributor to the physical structure of reefs, and increased colonisation by small crustaceans was also observed. REIMERS & BRANDEN (1994) investigated the relationship between time of placement of artificial reefs and rate of colonisation. They observed algal colonisation to be greatest during late spring and summer, and recommended that future (tire) reefs be installed at that time of year. Data from artificial and natural reefs in southern California indicated that algal, invertebrate and fish communities were generally similar on artificial and natural reefs (AMBROSE 1994).

A few authors also addressed the aspect of productivity of the epifouling communities on the artificial hard bottom. BLOWIND (2005) reported the living biomass per mussel (*Mytilus edulis*) attached to the piles in both the Yttre Stengrunden and Utgrunden wind farms to be several times larger than those collected from the seafloor. From the Nysted offshore wind farm, it was reported that the biomass of mussels and barnacles on the turbine piles was about ten times higher than that of those on the stones (scour protection) (BIRKLUND & PETERSEN 2004). A thick and dense layer of mussels covered a monitoring mast deployed several years earlier in this development area. The biomass of common mussels on the mast was about four times higher than the maximum biomass of mussels on the shafts of the turbines in 2003. HATCHER (1994) calculated for the Poole Bay artificial reef that production (per unit area) of the sessile reef epifauna

and sand macrobenthos was similar, whilst the bases of the freestanding slabs were at least twice as productive as any face of the reef blocks. FOSTER ET AL. (1994) investigated the mitigation potential of a concrete artificial reef in Delaware Bay. It was found that the artificial reef complex enhanced gross benthic biomass at the reef site about 147 to 895 fold over the benthic infauna in the study area, based on a standard area of Bay bottom, the reef module "footprint". BURTON ET AL. (2002) mention great variation in production of the same artificial reef in Delaware Bay due to the large annual differences in blue mussel (*Mytilus edulis*) biomass. The authors conclude that the artificial reef provides enhanced benthic secondary production per unit area over the lost habitat, but that total production did not equal what had been lost.

In connection with artificial reefs, the benefit to certain species is discussed. LEONHARD & PEDERSEN (2005) found evidence that artificial hard bottom at Horns Rev wind farm served as a habitat and nursery ground for *Cancer pagurus*., Endangered species, both *Sabellaria spinulosa* and *Sertularia cupressina*, were also recorded on the newly introduced artificial substrate. HISCOCK ET AL. (2002) note that well-planned scour protection may provide a significant habitat for crustacean shellfish, especially lobsters, *Homarus gammarus*, but also brown crabs, *Cancer pagurus*, velvet swimming crabs, *Necora puber*, and various species of squat lobster. A survey of artificial reefs has revealed that lobsters were reported in only a small proportion of the projects or in smaller numbers than expected (SPANIER 1994, SCARRATT 1968). It was concluded that the majority of reefs did not fit the behavioural-ecological preferences of lobsters for shelter. On the other hand, JENSEN ET AL. (1994) reported that lobsters quickly colonised an experimental artificial reef in Poole Bay on the English south coast, and that many individuals exhibited considerable long-term site loyalty. PAGE ET AL. (1999), in a study on large, highly mobile crab species in the Santa Barbara Channel (California, USA), found distribution and abundance in relation to an offshore oil platform of such species to fit into the following scenarios: (1) "recruitment/emigration", a platform provides recruitment habitat and individuals that recruit at the platform emigrate at some point to the surrounding environment; (2) "recruitment/resident", a platform provides recruitment habitat, but individuals remain in the vicinity of the structure; (3) "attraction", individuals recruited elsewhere are attracted to and aggregate at the platform; and (4) "visitor", individuals recruited elsewhere occur temporarily at the platform without aggregation. These results were concluded to illustrate the need to consider the responses of individual species to artificial structures (PAGE ET AL. 1999).

The so-called "reef effect" involves all changes of faunal communities in the vicinity of reef-like structures (e.g. wrecks, platforms, any kind of natural or artificial reef). Physical changes associated with the presence of the reef are changes in grain size composition and organic content of the sediment (SCHROEDER 1995). AMBROSE & ANDERSON (1990) for example, recorded an altered grain-size distribution of sediments around Pendelton Artificial Reef in Southern California. Sediments close to the modules were coarser than those 10 or 20 m away from the modules. Accumulation of faecal matters produced by reef organisms, of detached dead or live epifouling organisms, or of shells may attract and support certain faunal components (e.g. SCHROEDER 1995). HALL ET AL. (1993) suggest that it is food availability rather than particle size primarily determining community structure around a wreck in the northern North Sea. POSEY & AMBROSE (1994) provide support for a trophic link between the rock ledge and the adjacent soft-bottom communities. The result of their study indicate potentially important indirect effects of predator-prey interaction among the rock ledge-associated predators and soft-bottom prey. However, changes of surrounding infaunal communities appear to be limited to a small area around reefs or structures. Documentation of such changes has

only been carried out on a few occasions. The effects of an artificial reef in the central Adriatic Sea on the surrounding soft-bottom community were studied by FABI ET AL. (2002). An increasing proportion of sandy-bottom mollusc species was recorded with increasing distance from the structures. The effect was more pronounced in spring and autumn. AMBROSE & ANDERSON (1990) reported lower densities of one of the most common infaunal species, the polychaete *Prionospio pygmaeus*, in close vicinity of Pendleton Artificial Reef (Southern California). This observation was attributed to foraging by reef-associated predators, or decrease of habitat suitability near the reef. In general, the authors found no evidence that foraging by reef-associated fishes caused any widespread reduction in infaunal densities near the reef. In contrary, the other most common taxon, *Spiophanes* spp., exhibited higher densities near the reef. Also, the tube-dwelling worm *Diopatra ornata* only occurred in close association with the modules. Total infaunal density and densities of decapods, echinoderms and sipunculids were higher within *D. ornata* beds than outside the beds. An increase in the density of *Diopatra* spp (Polychaeta, Onuphidae) in the immediate vicinity of artificial reefs in shallow waters of San Diego County, southern California, was observed by DAVIS ET AL. (1982).

In the same article, the authors report that foraging by reef-associated fishes led to profound alterations in the population of the sea pen *Stylatula elongata*. Whereas 4-10 ind/m<sup>2</sup> were found prior reef deployment, the species was eliminated within 5 months from an area within 200 m around the reef. In a study at experimental artificial reefs located off the central Florida east coast, small infauna was significantly reduced within 1 m of the reef 3 months after reef deployment; the authors suggested that this was probably due to disturbance or feeding by fish (NELSON ET AL. 1988). LINDQUIST ET AL. (1994) investigated reef fish stomach contents and prey abundance on reef and sand substrata associated with adjacent artificial and natural reefs in Onslow Bay, North Carolina, USA. The results of their study implied that sand substrata organisms around reefs should be carefully considered as potentially important prey supporting reef fishes. DANOVARO ET AL. (2002) focused their studies on changes in the meiofauna. Spatial distribution of meiofaunal assemblages was investigated at two localities along transects running from within the reef to well outside its direct sphere of influence. Highest densities of meiofauna were recorded within 2-20 m from the reef area; lowest densities were found among the reef blocks. MONTAGNA ET AL. (2002) also concluded the occurrence of reef effects in meiofaunal communities near offshore hydrocarbon platforms in the Gulf of Mexico.

## 6 Conclusions and Recommendations

Reviewing the information compiled in this report, it seems obvious that detailed predictions about the impact of wind farms on benthic communities cannot be made. There is a lack of studies explicitly addressing wind farm issues. Most results are conclusions by analogy. The sources of information expected to be most valuable for an assessment of impacts, surveys undertaken in the course of wind farm development, is very limited in the literature published to date.

The general assumption found in many EIA reports is that there will be local changes due to construction activities and later, due to the presence and colonisation of the turbines (including foundation structures and, if present, scour protection). The impact sources "noise and vibration" and "electromagnetic fields" are not considered as of great significance. As to heat emission from power cables, the discussion is controversial.

The main focus is on the “reef effect”, although there is no agreement on how to judge the benefit for certain species against the alteration of the character of the habitat. The definition of threshold values for both impacts on benthic habitats and communities is impossible on the basis of current knowledge.

An improvement of the situation can be gained only by conducting fundamental research and by the application of effective monitoring programs to on-going wind farm developments. Apart from comprehensive monitoring during the post-construction phase, studies documenting all changes caused by wind farm operation should also accompany construction activities. A specific concept considering natural conditions at sites, technical specifications and the kind of construction activity must be developed. A monitoring concept in a generalised form applying to the operational phase is proposed in the next chapter.

## 6.1 Effect Monitoring

Offshore wind farms may cause a wide range of small-scale and large-scale changes to the current status of the local benthic environment. The main purpose of effect monitoring for the construction and operational phase is to provide necessary information for assessing the extent of spatial and temporal changes in seabed conditions and biological community structure due to the construction or presence of a wind farm.

For several parameters the effective range of change is likely to vary, depending on such parameters as local oceanography, the substrate of the sea floor, the number of wind turbines in the area etc. Thus, when planning an effect monitoring programme, local and regional differences must be taken into account. Monitoring programmes will need to maintain a flexibility of approach.

### 6.1.1 Existing Concepts

For **German** developers the monitoring concept outlined in the **Standards for Environmental Impact Assessments** (StUK – *Standarduntersuchungskonzept*) for Offshore Wind Turbines in the Marine Environment issued by German Federal Maritime and Hydrographic Agency (*Bundesamt für Seeschifffahrt und Hydrographie*/ BSH) (BSH 2003) is mandatory (Tab. 5). Based on these standards, the status of the respective development area prior to construction is documented in baseline studies. They comprise investigations of the substrate and habitat structure, investigations of epifaunal and infaunal communities, as well as of the macrophytobenthos, if present in the area investigated. Studies of sediment structure and dynamics apply to the entire project area during the baseline studies, but are confined to an area of single installations scheduled for biological studies. Studies on epifauna, infauna and macrophytobenthos include the complete project area during both baseline studies and effect monitoring though additional installation-oriented sampling is designated at two turbine sites during the monitoring phase. Also, in the construction phase and during operation of the wind farm, the surveys are extended by studies of the fouling communities which populate the piles and foundations. Sediment and habitat structure are investigated using side scan sonar (SSS) and sediment sampling (analysis in the laboratory), epifauna is studied by video and beam-trawling. Infauna samples are obtained with a Van Veen grab. Samples of the fouling communities are to be taken by divers.

Tab. 5 Excerpt from the German Standards for Environmental Impact Assessments (StUK – Standarduntersuchungskonzept) for Offshore Wind Turbines in the Marine Environment issued by German Federal Maritime and Hydrographic Agency (Bundesamt für Seeschifffahrt und Hydrographie BSH).

<b>German Standard (StUK; BSH 2003)</b>		
	<b>Baseline studies</b>	<b>Effect Monitoring</b>
<b>Sediment</b>	SSS survey covering the entire project and reference areas if possible (with a track spacing of 500 m as a minimum)	Surveys in the area of the single installations scheduled for biological studies Running of SSS transect lines
<b>Epifauna (Video)</b>	Video transects in the area of all beam trawl surveys (small beam trawl) and/or dredge surveys. The minimum number of video transects and/or photo stations is 10. Video surveys must be carried out together with the epifauna sampling.	
<b>Epifauna (beam trawl)</b>	Random distribution of stations taking into account the entire habitat pattern determined in the side scan sonar and video surveys.	
		An installation oriented sampling design according to the OSPAR Guidelines for Monitoring the Environmental Impact of Offshore Oil and Gas Activities (OSPAR Commission 2001) must be carried out additionally at two wind turbines as a minimum.
<b>Fouling community on piles and foundations</b>		Survey of the piles / foundations of at least two installations at three different water depths each (near surface, medium level, near bottom) Taking of scratch samples by divers, and photo/video documentation
<b>Infauna</b>	Coarse station grids (spacing should not exceed 1 nautical mile) in the project and reference areas. At least 20 stations in small areas (< 20 square nautical miles).	
		An installation oriented sampling design according to the OSPAR Guidelines for Monitoring the Environmental Impact of Offshore Oil and Gas Activities (OSPAR Commission 2001) must be carried out additionally at two wind turbines as a minimum
<b>Macrophytobenthos</b>	At least 3 transects in each habitat type occurring in the project area	

During the post-construction monitoring at the **Horns Rev wind farm** in the North Sea in Denmark, both the infaunal community and the hard bottom fauna were studied. The wind farm area was described as relatively uniform in regard to bottom conditions. The sediment was characterised as medium-grained sand with no organic matter. Particle size ranges from 228 µm to 426 µm.

The survey in September 2004, in the second year after operation of the wind farm had started, included collection of core samples at six selected turbine sites and at six stations in a designated reference area outside the wind farm area. The samples taken in the vicinity of the turbine sites were collected at three stations located 5 m, 25 m and 100 m from the scour protection of each turbine tower along transects in the lee of the

prevailing current. Additional samples were collected for analysis of sediment parameters. Sampling was conducted by SCUBA divers.

The hard bottom fauna populating monopile foundations and scour protection was studied at six different turbine sites selected according to depth regime and location in the wind park. Samples were collected by SCUBA divers along a transect in the direction of the main current. Three stations at distances 0.5 m, 2 m and 5 m from the monopiles were selected along the transects. As a reference, one station was sampled additionally at a distance 5 m upstream from the mono-pile. At each station, three replicate samples of fouling organisms were scraped off the stone blocks within a frame of defined size, using a scraping tool and an underwater air-lift device. At three locations, samples were also obtained from both the current-ward and the leeward side of the monopile at depth intervals of 2 m. In addition to visual studies and photographic documentation, the studies on the monopiles included the collection of quantitative samples by SCUBA divers to determine the composition of species, abundance, and biomass.

Effect monitoring conducted at the **Nysted wind farm** (Baltic Sea, Denmark) mainly focused on the fouling communities populating foundations (shafts), stone fillings inside the cells of the foundations and scour protection at the turbine sites and the transformer station. A limited sampling programme with regard to infauna organisms was realised in the vicinity of a power cable trench.

Sampling methods for the fouling community studies included underwater video recording, photography of images of a defined area, and quantitative sampling. In addition to the transformer platform, the foundations of seven turbines were investigated. Foundations were picked according to water depth and location within the wind farm area. Sampling and observation was conducted along four transects in northward, eastward, westward and southward direction from each turbine such that both horizontal and vertical distribution of epifaunal organisms could be documented. A square steel frame of defined size with an attached plankton net was used for the quantitative sampling. SCUBA divers scraped off all organisms and collected them in the net bag. A total of twenty photos and fifteen quantitative samples was taken at each turbine site.

Methods during the survey along the cable trench included underwater photography and underwater video ("photosampling") as well as collection of quantitative samples of benthic flora and fauna. Infauna samples were obtained using a Van Veen grab. Samples of the marine flora were collected by SCUBA divers. Photos were taken with a so-called "photosampler", consisting of a Nikon reflex camera in an Aquatica underwater box mounted on a steel frame of defined size, together with two strong flashlights and a video camera connected to a monitor and a video recorder onboard the ship. The surveys included "impact stations" located in the trench line and "control" or reference stations located 100 m, 200 m and 500 m east and west of the trench line.

---

All monitoring concepts discussed above require critical revision. For example, both the Danish concepts are very much focused on what happens around the turbine sites. Although it is important to document what species inhabit the new biotope and what the structure of the community is like, the impact on the fauna at a larger scale, means the fauna of the wind farm area as such, cannot be assessed. Also, the first step of any

kind of before/after comparisons should be to document possible changes in the marine environment (presence of scour pits, changes of sediment structure etc.). The sampling design should then be adjusted for all following studies to these findings.

The German Standard presents a general approach. A more detailed definition of targets would be helpful, and would enhance the survey structure. Also, there might be a problem regarding the methods of investigation. At a number of proposed wind farm sites in the German Exclusive Economic Zone, scuba diving will be very difficult (depth > 30 m, strong tidal currents) and hence, cost-intensive. Sampling of epifauna by dredging/trawling might also not be an option in the wind farm area, for safety reasons (damage to cable connections etc.).

### **6.1.2 Proposal for a Monitoring Concept for the Operational Phase of Offshore Wind Farms in the German EEZ -Benthos and Habitat Structure-**

In general, a distinction should be made between large and small-scale effects. The term large-scale effects here refers to effects involving the entire wind farm area. Small-scale effects are considered to be those detectable in the vicinity of turbine sites or other technical structures (e.g. transformer platforms, monitoring masts) in the wind farm. Documentation of large and small-scale effects must be approached differently. However, the results of the different practical approaches must be combined in the discussion, since they could, in synthesis, provide an explanation for what has been observed.

Measurements of salinity, temperature and oxygen levels should be mandatory during all field studies, so as to obtain a representative picture of the hydrographic situation in the area.

#### **A) Documentation of Large-Scale Effects**

In regard to large-scale effects, the relevant question is: What changes can be observed in comparison to the results of baseline studies? As a result of the baseline studies, habitat structure, sediment characteristics and presence and spatial distribution of various benthic communities in the wind farm area, are known. These findings should be compared to those from the operational phase. Also, investigation of a reference area has been included in baseline studies. The reference area serves for documentation of the development of the environmental features in the project area without the impact of wind turbines. Both the wind farm and the reference area should be studied in an analogous manner during the operational phase according to the proposed concept (Tab. 6).



Tab. 6 Proposal for a monitoring concept for the operational phase of offshore wind farms in the German EEZ to document large-scale effects regarding changes of both habitat structure and benthic communities.

<b>Documentation of Large-Scale Effects</b>	
<b>Sediment characteristics – habitat structure</b>	
Background/Targets	Comparison of current state of bottom morphology and sediment distribution with results from baseline studies
Methods	Hydro-acoustical techniques (Side Scan Sonar, echo sounder); Determination of sediment parameters (laboratory analysis of sediment samples) Video recordings with ROV (remotely operated vehicle)
Sampling Design	The entire project and reference area should be covered for SSS (or echo sounder) studies Sediment samples should be obtained together with infauna (grab) samples (see under infauna for sampling design) Video recordings should be supplementary supporting interpretation of the results of hydro-acoustical studies
Frequency and time of survey	Once a year, sediment samples annually together with macrobenthos samples in spring
Presentation of result	Maps of bottom morphology and substratum type covering the entire wind farm area plus the reference area Video; photos
<b>Infauna</b>	
Background/Targets	Comparison of current state of both presence and spatial distribution of different types of infaunal benthic communities with results from baseline studies
Methods	Grab sampling (Van Veen Grab)
Sampling Design	Single samples in a representative number for each identified habitat and substrate type in the wind farm and reference area
Frequency and time of survey	Once a year in spring
Presentation of result	Descriptive parameters for communities present (species lists, dominance structure, abundance, biomass) Spatial distribution of communities present Comparison with <i>status quo ante</i> (relevant statistical analyses)

## B) Documentation of Small-Scale Effects

As regards small-scale effects, the relevant question is: What changes can be observed in the vicinity of the turbines? Investigations of the fauna associated with the artificial hard bottom are crucial for understanding the reasons for potential changes in the local benthic community. There are various aspects to consider for the monitoring: fouling organisms covering the piles, the turbine foundations and the scour protection (if present); vagile organisms, such as various crab species or little amphipods retreating to the crevices between the stones or hiding among fouling organisms, and marine flora attached to the hard bottom; and possibly, a distinctive epifaunal community established in the vicinity of the turbine sites, attracted by the “reef”, and providing e.g. food and protection. For the fouling communities, both quantitative and qualitative sampling can be realised. An experimental approach even allows an assessment of production rates.

For other fauna associated with the turbines only qualitative and semi-quantitative studies can be conducted in the scope of a routine monitoring. Again, detailed studies of sediment characteristics and habitat structure are the essential precondition for interpreting the results of the faunal studies.

Tab. 7 Proposal for a monitoring concept for the operational phase of offshore wind farms in the German EEZ to document small-scale effects regarding changes of both habitat structure and benthic communities.

<b>Documentation of Small-Scale Effects</b>	
<b>Sediment characteristics – habitat structure</b>	
Background/Targets	Description of the current state of bottom morphology and sediment distribution in the close vicinity of at least 3 selected wind turbines (documentation of scour pits, sediment transfer etc.) The same for other introduced structures (transformer platform etc.)
Methods	Hydro-acoustical techniques (Side Scan Sonar, echo sounder) in close vicinity to either the turbine foundations or, if present, the scour protection Video recordings with ROV (remotely operated vehicle)
Sampling Design	Selection of turbine sites according to depth, sediment and hydrographic regime as well as the location of the turbine within the wind farm area A circular area with $r \geq 50$ m and the wind turbine (or the introduced structure) in the center should be covered by hydro-acoustical studies Scour pits, if present, have to be documented completely, the same applies to other potential changes in sediment distribution related to the presence of the wind turbine/artificial structure in general Supplementary video recordings supporting interpretation of the results of hydro-acoustical studies
Frequency and time of survey	Once a year
Presentation of result	Maps of bottom morphology and substratum type covering the area studied Video; photos
<b>Infauna (conditionally) in the vicinity of the introduced structures</b>	
Background/Targets	For obtaining additional data if unusual observations/circumstances justify the service of SCUBA divers
Methods	Core sampling techniques
Sampling Design Frequency and time Presentation of result	Dependent on the study background
<b>Epifauna in the vicinity of the introduced structures</b>	
Background/Targets	Description of the epifaunal communities established on the local substrate in the vicinity of at least 3 selected wind turbines The same for other introduced structures (transformer platform etc.) Documentation of potential “reef effect”
continues next page	
Methods	Video recordings with ROV in close vicinity to either the turbine foundations (introduced structure) or, if present, the scour protection “Photosampling” (photography of areas of defined sizes)
Sampling Design	Selection of study sites: the same as turbines/structures studied regarding changes of sediment characteristics and habitat structure

	<p>A circular area with <math>r \geq 50</math> m and the wind turbine (or the introduced structure) in the center should be investigated</p> <p>Area of scour pits, if present, must be considered in its complete extension, the same applies to other potential changes in sediment distribution related to the presence of the wind turbine/artificial structure in general</p> <p>Video recording time approx. 30 min</p> <p>Representative number of photosamples for semi-quantitative analyses (dependent on conditions at the study site)</p>
Frequency and time of survey	Twice a year (early spring and late summer/beginning of autumn)
Presentation of result	<p>Descriptive parameters (species lists, dominance structure)</p> <p>Spatial distribution of epifaunal organisms</p> <p>Comparison with <i>status quo ante</i> (baseline studies)</p>
<b>Fouling communities and other fauna associated with the artificial hard bottom</b>	
Background/Targets	<p>Study of the fouling communities populating both the wind turbine piles and the scour protection at not less than 3 selected turbine sites</p> <p>Study of fauna associated with the artificial hard bottom</p> <p>The same for other introduced structures (transformer platform etc.)</p>
Methods	<p>Video recordings with ROV of fouling communities (of the turbine piles, of the turbine foundations and of the scour protection) and other fauna present on the artificial hard bottom</p> <p>“Photosampling” (photography of areas of defined sizes)</p> <p>Experimental approach: installation of plates for measurements of the productivity of the sessile fouling community</p>
Sampling Design	<p>Selection of study sites: the same as turbines/structures studied regarding changes of sediment characteristics and habitat structure</p> <p>Video recording time approx. 30 min (qualitative assessment of fauna associated with the artificial hard bottom)</p> <p>Representative number of photosamples for documentation of vertical zonation of fouling communities on the turbine piles</p> <p>Representative number of photosamples for qualitative/semi-quantitative analyses of fouling communities on the turbine foundations</p> <p>Representative number of photosamples for qualitative analyses of fouling communities on the scour protection</p> <p>Representative number of photosamples for qualitative analyses of fouling communities on the scour protection</p> <p>Exposition of (movable) plates at three depths (3 plates per depth)</p>
Frequency and time of survey	<p>Twice a year (early spring and late summer/early autumn)</p> <p>Plate sampling for productivity measurements at monthly intervals during the first year and biannually during following years</p> <p>Some of the plates should not be sampled before the second or third year (to follow succession)</p>
Presentation of result	<p>Descriptive parameters for fauna present in the different habitats investigated (turbine piles, turbine foundations, scour protection, area in the vicinity of turbine site) - species lists, dominance structure, abundance, biomass (as far as possible with respect to sampling design)</p> <p>Description of spatial distribution</p> <p>Estimation of secondary production of the sessile fouling community</p>

### C) Additional Studies

One of the major problems assessing possible effects on organisms in the marine environment is the lack of field data. For example, heat emission from cables transmitting electrical power within the wind park and from the offshore wind farm to the coast has been calculated based on physical models, but calculation results comparing the different reports are not really incongruous. Moreover, heat dissipation into the sediment and temperature rise depend on such parameters as sediment type, ambient temperature conditions, water currents, water depth, power production of the wind farm etc. That makes it difficult to realistically predict any impacts on the marine fauna and flora. Greatest effects might occur in coastal tidal soft-sediments, where several cables run next to each other. The opportunity to gather field data of sediment temperature around underwater power cables as part of the monitoring should be taken. Measurements should be undertaken at two localities: 1) at the cable connection to the shore; and 2) at the park-internal cable net where highest transmission rates are anticipated (most likely close to the transformer station). Also, it is important to obtain reference data of sediment temperature from an undisturbed locality.

The aspect of heat emission from power cables should also be studied in the scope of research projects. It is necessary to choose a holistic approach, including aspects of sediment chemistry, microbiology, microphytobenthos, meiofauna and macrofauna. That would reveal functional relationships, and provide a basis for understanding potential effects and how to handle them.

### D) Recommendations for the Monitoring Reports

For the monitoring reports, it does not seem appropriate to address only selected aspects of the field studies (e.g. a report exclusively on the fauna of the turbines etc.), since that might make it difficult to assess potential effects or to shed light on the background of observed changes. These reports should elaborate what changes in comparison to the baseline studies could be observed. Relevant questions to be answered include:

1. What changes regarding sediment regime and habitat structure could be observed?
2. Has the infauna community populating the wind farm area changed, and to what extend?
3. Are there records of new species? Have species disappeared from the area?
4. What is the community associated with the artificial hard bottom like?
5. Does excretion/death of sessile hard-bottom fauna affect the food supply of endobenthic invertebrates in the vicinity of the wind turbines?
6. Does an increase in the biomass of epibenthic predators (crabs, fishes) affect the community structure of endobenthic invertebrates in the vicinity of the wind turbines? Can a "reef effect" be postulated?
7. Can the observed changes be related to the presence of the wind farm?

Results should be presented in an appropriate form; data analyses must be carried out according to the relevant statistical methods.

## 7 References

- ACHITUV Y, COOK P. A. (1984): The influence of temperature variations and thermal pollution on various aspects of the biology of the prawn *Palaemon pacificus* (Stimpson). *Journal of Experimental Marine Biology and Ecology* 74: 291-302.
- AMBROSE, R. F. & ANDERSON, T. W. (1990): Influence of an artificial reef on the surrounding infaunal community. *Marine Biology* 107: 41-52.
- AMBROSE, R. F. (1994): Mitigating the effects of a coastal power-plant on a kelp forest community - rationale and requirements for an artificial reef. *Bulletin of Marine Science* 55: 694-708.
- ANDRULEWICZ, E., NAPIERSKA, D. & OTREMBA, Z. (2003): The environmental effects of the installation and functioning of the submarine SwePol Link HVDC transmission line: a case study of the Polish Marine Area of the Baltic Sea. *Journal of Sea Research* 49: 337-345.
- ARENDSE, M. C. & BARENDREGT, A. (1981): Magnetic orientation in the semi-terrestrial amphipod *Orchestria cavimana*, and its interrelationship with photo-orientation and water loss. *Physiol. Entomol.* 6: 333-342.
- ARENDSE, M. C. (1978): Magnetic field detection is distinct from light detection in the invertebrates *Tenebrio* and *Talitrus*. *Nature* 274: 358-362.
- BAKER, T. (2003): Offshore wind energy generation: phase 1 proposals and environmental report – for consideration by the Department of Trade and Industry. Report by BMT Cordah Limited, [www.og.dti.gov.uk/offshore-wind-sea/process/envreport.htm](http://www.og.dti.gov.uk/offshore-wind-sea/process/envreport.htm)
- BALL, B.J., FOX, G. & MUNDAY, B.W. (2000): Long- and short-term consequences of a *Nephrops* trawl fishery on the benthos and environment of the Irish Sea. *Ices Journal of Marine Science* 57: 1315-1320.
- BAMBER, R. N. & SPENCER, J. F. (1984): The benthos of a coastal power station thermal discharge canal. *Journal of the Marine Biological Association of the United Kingdom* 64: 603-623.
- BERGMAN, M.J.N. & VAN SANDBBRINK, J.W. (2000): Mortality in megafaunal benthic populations caused by trawl fisheries on the Dutch continental shelf in the North Sea in 1994. *Ices Journal of Marine Science* 57: 1321-1331.
- BIOWIND (2005): Wind power plants in the sea – A method to locally increase the biodiversity in the Baltic Sea. Report to the National Energy Agency, Wind research program, 12 pp.
- BIRKLUND, J. (2003): Marine Biological Surveys Along the Cable Trench in the Lagoon of Rødsand in September 2002 and March 2003. Report by the DHI Water & Environment commissioned by SEAS Distribution A.m.b.A., Hørsholm (Denmark), 37 pp.
- BIRKLUND, J. & PETERSEN, A. H. (2004): Development of the fouling community on turbine foundations and scour protections in Nysted Offshore wind farm, 2003. Report by Energi E2 A/S, 42 pp.
- BOCHERT, R. & ZETTLER, M. L. (2004): Long-term exposure of several marine benthic animals to static magnetic fields. *Bioelectromagnetics* 25: 498 – 502.
- BONSDORFF, E. (1983): Recovery potential of macrozoobenthos from dredging in shallow brackish waters. *Oceanologica Acta, Proceedings 17<sup>th</sup> European Marine Biology Symposium, Brest, France, 27-32.*
- BONSDORFF, E., NORKKO, A. & SANDBERG, E. (1995): Structuring zoobenthos: the importance of predation, siphon cropping and physical disturbance. *Journal of Experimental Marine Biology and Ecology* 192: 125-144.
- BOSSELMANN, A. (1988): Settlement and succession of benthic animals - a subtidal experiment in the German Bight compared with the "Benthosgarten" experiment in Kiel Bay. *Kieler Meeresforschungen* 6: 375-388.
- BRADSHAW, C., VEALE, L.O. & BRAND, A.R. (2002): The role of scallop-dredge disturbance in long-term changes in Irish Sea benthic communities: a re-analysis of an historical dataset. *Journal of Sea Research* 47: 161-184.
- BRAKELMANN, H. (2005): Kabelverbindung der Offshore-Windfarmen Kriegers Flak und Baltic I zum Netzanschlusspunkt. Report commissioned by the Offshore Ostsee Wind AG, 71 pp.
- BUCKLEY, R. M. & HUECKEL, G. J. (1985): Biological processes and ecological development on an artificial reef in Puget-Sound, Washington. *Bulletin of Marine Science* 37: 50-69.
- BURTON, W.H., FARRAR, J. S., STEIMLE, F. & CONLIN, B. (2002): Assessment of out-of-kind mitigation success of an artificial reef deployed in Delaware Bay, USA. *Ices Journal of Marine Science* 59: 106-110.

- CAEM (2002): Chips, hits, bits & bytes: tools for transmission. Available [http://www.caem.org/website/pdf/Grid\\_Final.pdf](http://www.caem.org/website/pdf/Grid_Final.pdf)
- CHAPMAN, P. M., POWER, E. A., DEXTER, R. N. & ANDERSEN, H. B. (1991): Evaluation of effects associated with an oil platform, using the sediment quality triad. *Environmental Toxicology and Chemistry* 10, 407-424
- CMACS (2003): A baseline assessment of electromagnetic fields generated by offshore wind farm cables. COWRIE Report EMF - 01-2002 66. Available [http://www.thecrownstate.co.uk/print/1351\\_emf\\_research\\_report\\_04\\_05\\_06.pdf](http://www.thecrownstate.co.uk/print/1351_emf_research_report_04_05_06.pdf)
- COOPER, B. & BEIBOER, F. (2002): Potential effects of offshore wind developments on coastal processes. ETSU W/35/00596/00/REP, URN 02/1336. Report by ABP Marine Environmental Research Ltd and Metoc plc. on behalf of the Department of Trade and Industry, Energy Technology Support Unit, [www.abpmer.co.uk](http://www.abpmer.co.uk)
- COWIE, P.R., WIDDICOMBE, S. & AUSTEN, M.C. (2000): Effects of physical disturbance on an estuarine intertidal community: field and mesocosm results compared. *Marine Biology* 136: 485-494.
- CREMA, R. & BONVICINI PAGLIAI, A. M. (1980): The structure of benthic communities in an area of thermal discharge from a coastal power station. *Marine Pollution Bulletin* 11: 221-224.
- CRIPPS, S. J. & AABEL, J. P. (2002): Environmental and socio-economic impact assessment of Ekoreef, a multiple platform rigs-to-reef development. *ICES Journal of Marine Science* 59: 300-308.
- CURRIE, D. R. & ISAACS, L. R. (2005): Impact of exploratory offshore drilling on benthic communities in the Minerva gas field, Port Campbell, Australia. *Marine Environmental Research* 59: 217-233
- DAAN, R., Mulder, M. & Vanleeuwen, A. (1994): Differential sensitivity of macrozoobenthic species to discharges of oil-contaminated drill cuttings in the North Sea. *Netherlands Journal of Sea Research* 33: 113-127
- DAAN, R. & MULDER, M. (1996): On the short-term and long-term impact of drilling activities in the Dutch sector of the North Sea. *Ices Journal of Marine Science* 53: 1036-1044.
- DANISH WIND INDUSTRY ASSOCIATION (2003): Annual Report. [www.windpower.org/composite-46.htm](http://www.windpower.org/composite-46.htm)
- DANOVARO, R., GAMBI, C., MAZZOLA, A. & MIRTO, S. (2002): Influence of artificial reefs on the surrounding infauna: analysis of meiofauna. *Ices Journal of Marine Science* 59: 356-362.
- DAUER, M. D. & SIMON, J. L. (1976): Repopulation of the polychaete fauna of an intertidal habitat following natural defaunation: species equilibrium. *Oecologia* 22: 99-117.
- DAVIS, N., VAN BLARICOM, G. R., DAYTON, P. K. (1982): Man-made structures on marine sediments: effects on adjacent benthic communities. *Marine Biology* 70: 295-303.
- DE VOOYS, C. G. N. (1990): Expected biological effects of long-term changes in temperatures on benthic ecosystems in coastal waters around the Netherlands. In: J. J. Beukema & J.J. W. M. Brouns (Eds.) *Expected effects of climatic change on marine coastal ecosystems*, Kluwer Academic Publishers, Netherlands, 77-82.
- DINET, A., NODOT, C., VITIELLO, P. & VIVIER, M. H. (1982): Impact of a thermal effluent on benthic harpacticoid copepod community. *Tethys* 10: 355-363.
- DWI (2004): Standardverfahren zur Ermittlung und Bewertung der Belastung der Meeresumwelt durch die Schallimmission von Offshore-Windenergieanlagen. Final report No. 0327528 A, commissioned by and submitted to the BMU, Available <http://www.erneuerbare-energien.de/files/pdfs/allgemein/>
- ELEFThERIOU, A. (2000): Marine Benthos Dynamics: Environmental and Fisheries Impacts - Introduction and Overview. *Ices Journal of Marine Science* 57: 1299-1302.
- EOS OFFSHORE AG (2003): Parkinterne Verkabelung - Berechnung der Temperaturverteilung im Meeresboden. Report EOS Offshore AG, Varel, 10 pp.
- FABI, G., LUCCARINI, F., PANFILI, M., SOLUSTRI, C. & SPAGNOLO, A. (2002): Effects of an artificial reef on the surrounding soft-bottom community (central Adriatic Sea). *Ices Journal of Marine Science* 59: 343-349.
- Foster, K. R. (2000): Thermal and nonthermal mechanisms of interaction of radiofrequency energy with biological systems. *IEEE Trans Plasma Science* 28:17-23.
- FOSTER, K. L., STEIMLE, F. W., MUIR, W. C., KROPP, R. K. & CONLIN, B. E. (1994): Mitigation potential of habitat replacement concrete artificial reef in Delaware Bay - preliminary results. *Bulletin of Marine Science* 55: 783-795,
- FOSTER, K. R. & REPACHOLI, M. H. (year of publication unknown): Environmental Impacts of Electromagnetic Fields From Major Electrical Technologies. EMF Project report. Available <http://www.who.int/peh-emf/publications/reports/en>

- FRID., CLARK, R. A. & HALL, J. A. (1999): Long-term changes in the benthos on a heavily fished ground off the NE coast of England. *Marine Ecology Progress Series* 188: 13-20.
- FRID, C. L. J., HARWOOD, K. G., HALL, S. J. & HALL, J. A. (2000): Long-term changes in the benthic communities on the North Sea fishing grounds. *Ices Journal of Marine Science* 57: 1303-1309.
- GERASCH, W.-J & UHL, A. (2003): Schallabstrahlung und –ausbreitung. In: Bau- und umwelttechnische Aspekte von Off-shore Windenergieanlagen. Final report No. 0329894 A, commissioned by and submitted to the BMWi and BMU, Available <http://www.gigawind.de>
- GIGAWIND (2004): Bau- und umwelttechnische Aspekte von Off-shore Windenergieanlagen Final project report 2000 – 2003, 0329894A. AVAILABLE [www.gigawind.de](http://www.gigawind.de)
- GOLDBERG, E. D. & BERTINE, K. K. (2000): Beyond the mussel watch – new directions for monitoring marine pollution. *The Science of the Total Environment* 247: 165-174.
- GÓMEZ GESTEIRA, J. L. & DAUVIN, J. C. (2000): Amphipods are good bioindicators of the impact of oil spills on soft-bottom macrobenthic communities. *Marine Pollution Bulletin* 40: 1017-1027.
- GRANT, A. & BRIGGS, A. D. (2002): Toxicity of sediments from around a North Sea oil platform: are metals or hydrocarbons responsible for ecological impacts? *Marine Environmental Research* 53: 95-116.
- GRAY, J. S, CLARKE, K. R, WARWICK R. M. & HOBBS, G. (1990): Detection of initial effects of pollution on marine benthos: an example from the Ekofisk and Eldfisk oilfields, North Sea. *Marine Ecology Progress Series* 66: 285-299.
- GROENEWOLD, S. & FONDS, M. (2000): Effects on benthic scavengers of discards and damaged benthos produced by the beam-trawl fishery in the southern North Sea. *Ices Journal of Marine Science* 57: 1395-1406.
- GRUET, Y. (1971): Morphologie, croissance et faune associée des récifs de *Sabellaria alveolata* (Linné). Thèse doctorat, Université de Nantes, 238 pp.
- GÜNTHER, C. P. (1992): Dispersal of intertidal invertebrates: a strategy to react to disturbances of different scales? *Netherlands Journal of Sea Research* 30: 45-56.
- HALL, S. J., ROBERTSON, M. R., BASFORD, D. J. & HEANEY, S. D. (1993): The possible effects of fishing disturbance in the northern North Sea: an analysis of spatial patterns in community structure around a wreck. *Netherlands Journal of Sea Research* 31: 201-208.
- HALL-SPENCER, J. M. & MOORE, P. G. (2000): Scallop dredging has profound, long-term impacts on maerl habitats. *ICES Journal of Marine Science* 57: 1407-1415.
- HATCHER, A. M. (1994): Epifaunal development on an artificial reef. *Bulletin of Marine Science* 55: 1336-1337.
- HATCHER, A. M. (1998): Epibenthic colonisation patterns on slabs of stabilised coal-waste in Pools Bay, UK. *Hydrobiologia* 367: 153-162.
- HISCOCK, K., SOUTHWARD, A., TITTLE, I. & HAWKINS, S. (2004): Effects of changing temperature on benthic marine life in Britain and Ireland. *Aquatic Conservation: Marine and Freshwater Ecosystems* 14: 333-362.
- HISCOCK, K., SOUTHWARD, A., TITTLE, I., JORY, A. & HAWKINS, S. (2001): The impact of climate change on subtidal and intertidal benthic species in Scotland. Edinburgh, Scottish Natural Heritage (Survey and Monitoring Series).
- HISCOCK, K., TYLER-WALTERS, H. & JONES, H. (2002): High level environmental screening study for offshore wind farm developments – marine habitats and species project. Report from the Marine Biological Association to DTI New & Renewable Energy Programme. AEA Technology, Environment contract: W/35/00632/00/00.
- HOFFMANN, E. & DOLMER, P. (2000): Effect of closed areas on distribution of fish and epibenthos. *Ices Journal of Marine Science* 57, 1310-1314.
- JENSEN, A. C., COLLINS, K. J., FREE, E. K. & BANNISTER, R. C. A. (1994): Lobster (*Homarus gammarus*) movement on an artificial reef - the potential use of artificial reefs for stock enhancement. *Crustaceana* 67: 198-211.
- JOSCHKO, T., OREJAS, C., SCHRÖDER, A. & KNUST, R. (2004): Dokumentation der Ansiedlungsprozesse an künstlichen Hartsubstraten in der Nordsee. *DEWI Magazin* 25: 43-44.
- KAILASAM, M. & SIVAKAMI, S. (2004): Effect of thermal discharge on benthic fauna off Tuticorin Bay, south east coast of India. *Indian Journal of Marine Sciences* 32(2):194-201.
- KENNY, A. J. & REES, H. L. (1996): The Effects of Marine Gravel Extraction on the Macrobenthos: Results 2 Years Post-Dredging. *Marine Pollution Bulletin* 32: 615-622.

- KESER, M., SWENARTON, J. T., VOZARIK, J. M. & FOERTCH, J. F. (2003): Decline in eelgrass (*Zostera marina* L.) in Long Island Sound near Millstone Point, Connecticut (USA) unrelated to thermal input. *Journal of Sea Research* 49:11-26.
- KINGSTON, P. F. (1992): Impact of offshore oil production installations on the benthos of the North Sea. *ICES Journal of Marine Science* 49: 45-53.
- KNUST, R. (1997): Ökologische Begleituntersuchungen zum Projekt EUROPIPE, Teilprojekt Fische und Krebse. Final report by the Alfred-Wegener Institut für Polar- und Meeresforschung, Bremerhaven, Nationalparkverwaltung Niedersächsisches Wattenmeer, Wilhelmshaven, 57 pp.
- KNUST, R., DAHLHOFF, P., GABRIEL, J., HEUERS, J., HÜPPOP, O., WENDELN, H. (2003): Untersuchungen zur Vermeidung und Verminderung von Belastungen der Meeresumwelt durch Offshore - Windenergieanlagen im küstenfernen Bereich der Nord- und Ostsee. UBA-Text 62/03, 453 pp.
- KÖNNECKER, G. (1977): Epibenthic assemblages as indicators of environmental conditions. In *Proceedings of the 11<sup>th</sup> Symposium on Marine Biology, Galway, October 1976. Biology of Benthic Organisms* (ed. B. F. Keegan, P. O. Ceidigh & P. J. S. Boaden), pp. 391-395. Oxford Pergamon Press
- KOOPS, F. B. J. (2000): Electric and magnetic fields in consequence of undersea power cables. In: *ICNIRP: Effects of Electromagnetic Fields on the Living Environment*, pp. 189 - 210
- KRAMER, K. (2000): Kabelbauarten sowie Verlegemethoden und ihre Auswirkungen auf magnetische und elektrische Felder im Meer. In: Merck T, von Nordheim H (Eds) *Technische Eingriffe in Marine Lebensräume, BfN-Skripten 29: 77 – 87*.
- KULLNICK, U. & MARHOLD, S. (2000): Direkte oder indirekte biologische Wirkungen durch magnetische und/oder elektrische Felder im marinen (aquatischen) Lebensraum: Überblick über den derzeitigen Erkenntnisstand. Teil I. In: Merck T, von Nordheim H (Eds) *Technische Eingriffe in Marine Lebensräume, BfN-Skripten 29: 4 – 18*.
- LAGARDÈRE, J. P. (1982): Effects of noise on growth and reproduction of *Crangon crangon* in rearing tanks. *Marine Biology* 71: 177-185.
- LARDICCI, C., ROSSI, F. & MALTAGLIATI, F. (1999): Detection of thermal pollution: variability of benthic communities at two different spatial scales in an area influenced by a coastal power station. *Marine Pollution Bulletin* 38 (4): 296-303.
- LEDER, A. (2003): Gutachterliche Stellungnahme zur Thematik: Beeinflussung der Wasserströmung durch einen Offshore-Windpark im Arkonabecken Südost. 20 pp.
- LEONHARD, S. B. & PEDERSEN, J. (2005): Hard bottom substrate monitoring Horns Rev Offshore Wind Farm - annual status report 2004. ELSAM Engineering, 79 pp.
- LINDEBOOM, H. J. (1995): Protected areas in the North Sea: an absolute need for future marine research. *Helgoländer Meeresuntersuchungen* 49: 591-602.
- LINDQUIST, D. G., CAHOON, L. B., CLAVIJO, I. E., POSEY, M. H., BOLDEN, S. K., PIKE, L. A., BURK, S. W. & CARDULLO, P. A. (1994): Reef fish stomach contents and prey abundance on reef and sand substrata associated with adjacent artificial and natural reefs in Onslow Bay, North Carolina. *Bulletin of Marine Science* 55: 308-318.
- LOHMANN, K. J. AND WILLOWS, A. O. D. (1987): Lunar-modulated geomagnetic orientation by a marine mollusk. *Science* 235, 331-334.
- LOHMANN, K. J., PENTCHEFF, N. D., NEVITT, G. A., STETTEN, G. D., ZIMMER-FAUST, R. K., JARRARD, H. E. & BOLES, L. C. (1995): Magnetic orientation of spiny lobsters in the ocean: experiments with undersea coil systems. *The Journal of Experimental Biology* 198: 2041–2048.
- LU, L. & WU, R. S. S. (2000): An experimental study on recolonization and succession of marine macrobenthos in defaunated sediment. *Marine Biology* 136: 291-302.
- MATTHÄUS, W. (1995): Ecological effects and technical aspects of the sea cable Germany – Sweden. German Scientific Commission for Marine Research, working group: Sea Cable Germany – Sweden. 11 pp. Available <http://members.iinet.net.au/~emfacts/basslink/ecological.html>
- MAURER, D., KECK, R. T., TINSMAN, J. C., LEATHAM, W. A., WETHE, C., LORD, C. & CHURCH, T. M. (1986): Vertical migration and mortality of marine benthos in dredged material: a synthesis. *Internationale Revue der Gesamten Hydrobiologie* 71: 49-63.
- MCCAULEY, R. D. (1994): Seismic surveys. In: Swan, J. M., Neff, J. M., Young, P.C. (Eds.) *Environmental implications of offshore oil and gas development in Australia – The findings of an independent Scientific Review*. APEA, Sydney



- METOC Plc (2000): An assessment of the environmental effects of offshore wind farms. ETSU W/35/00543/REP, submitted to DTI, Available <http://www.dti.gov.uk/energy/renewables/publications/pdfs/35-00543.pdf>
- MITTENDORF, K. & ZIELKE, W. (2002): Untersuchung der Wirkung von Offshore-Windenergie-Parks auf die Meeresströmung. Available [www.gigawind.de](http://www.gigawind.de)
- MONTAGNA, P., JARVIS, S. C. & KENNICUT, M. C. (2002): Distinguishing between contaminant and reef effects on meiofauna near offshore hydrocarbon platforms in the Gulf of Mexico. *Canadian Journal of Fisheries and Aquatic Sciences* 59: 1584-1592.
- MOORE, A. & COBB, J. L. S. (1986): Neurophysiological studies on the detection of mechanical stimuli in *Ophiura ophiura*. *Journal of Experimental Marine Biology and Ecology* 104: 125-141.
- MORTON, B. (1996): The subsidiary impacts of dredging (and trawling) on a subtidal benthic molluscan community in the southern waters of Hong Kong. *Marine Pollution Bulletin* 32: 701-710.
- NEDWELL, J. & HOWELL, D. (2004): A review of offshore wind farm related underwater noise sources. Report No. 544 R 0308, submitted to The Crown Estate, commissioned by COWRIE, Available <http://www.thecrownestate.co.uk/>
- NEDWELL, J., LANGWORTHY, J. & HOWELL, D. (2003): Assessment of sub-sea acoustic noise and vibration from offshore wind turbines and its impact on marine wildlife; initial measurements of underwater noise during construction of offshore wind farms, and comparison with background noise. Report No. 544 R 0424 submitted to The Crown Estate, commissioned by COWRIE, Available <http://www.thecrownestate.co.uk/>
- NELSON, W. G., NAVRATIL, P. M., SAVERCOOL, D. M. & VOSE, F. E. (1988): Short-term effects of stabilized oil ash reefs on the marine benthos. *Marine Pollution Bulletin* 19: 623-627.
- OFFSHORE WIND POWER LTD. (2002): Inner Dowsing Offshore Wind Farm. Volume 1 non-technical summary, 32 pp.
- OFFSHORE WIND TECHNOLOGIE GMBH (2004): Wärmeausbreitung im Meeresboden infolge Verlustwärme der Netzanbindung des Windparks "Borkum West" (Windnet I): Report commissioned by PROKON Nord Energiesysteme GmbH.
- OFFUT, G. C. (1970): Acoustic stimulus perception by the American Lobster *Homarus americanus*. *Experientia* 26: 1276-1278.
- OLSGARD, F. & GRAY, J. S. (1995): A comprehensive analysis of the effects of offshore oil and gas exploration and production on the benthic communities of the Norwegian continental shelf. *Marine Ecology Progress Series* 122: 277-306
- OWEN (2000): Structure and foundations design of offshore wind installations. EPSRC. 1 March 2000. Available [http://www.owen.org.uk/workshop\\_3/ws3\\_final.pdf](http://www.owen.org.uk/workshop_3/ws3_final.pdf)
- PACKARD, A., KALSEN, H. E. & SAND, O. (1990): Low frequency hearing in cephalopods. *Journal of Comparative Physiology* 166: 501-505.
- PAGE, H. M., DUGAN, J. E., DUGAN, D. S., RICHARDS, J. B. & HUBBARD, D. M. (1999): Effects of an offshore oil platform on the distribution and abundance of commercially important crab species. *Marine Ecology-Progress Series* 185: 47-57.
- PARDI, L., ERCOLINI, A., FERRARA, F. & SCAPINI, F. (1985): Orientamento zonale solare e magnetico in Crostacei Antipodi litorali di regioni equatoriali. *Att. Accad. Lincei Rend. Sci. Fis. Mat. Nat.* 76: 312-320.
- PHILLIPPART, C. J. M. (1989): Long-term impact of bottom fisheries on several by-catch species of demersal fish and benthic invertebrates in the south-eastern North Sea. *Ices Journal of Marine Science* 55: 342-352.
- POSEY, M. H. & AMBROSE, W. G. (1994): Effects of proximity to an offshore hard-bottom reef on infaunal abundances. *Marine Biology* 118: 745-753.
- REIMERS, H. & BRANDEN, K. (1994): Algal colonization of a tire reef - influence of placement date. *Bulletin of Marine Science* 55: 460-469.
- RUMOHR, H. & KROST, P. (1991): Experimental evidence of damage to benthos by bottom trawling with special reference to *Arctica islandica*. *Meeresforschung* 33: 340-345.
- RUMOHR, H. & KUJAWSKI, T. (2000): The impact of trawl fishery on the epifauna of the southern North Sea. *Ices Journal of Marine Science* 57: 1389-1394.
- SCARPINI, F. & QUOCHI, G. (1992): Orientation in sandhoppers from Italian populations – have they magnetic orientation ability? *Bull. Zool.* 59: 437-442.

- SCARRATT, D. J. (1968): An artificial reef for lobsters (*Homarus americanus*). Journal of the Fisheries Research Board of Canada 25: 2683-2690.
- SCHROEDER, A. (1995): Das Makrozoobenthos am West-Gamma-Wrack in der äußeren Deutschen Bucht – Zum Fischereieinfluss auf eine Bodenfaunagemeinschaft der Nordsee. Diplomarbeit Rheinische Friedrich-Wilhelm Universität, Bonn, 116 pp.
- SMITH, C. R. & BRUMSICKLE, S. J. (1989): The effects of patch size and substrate isolation on colonization modes and rates in an intertidal sediment. Limnol. Oceanogr. 34 (7): 1263-1277.
- SNOEIJIS, P. J. M. (1991): Monitoring Pollution Effects by Diatom Community Composition - A Comparison of Sampling Methods. Archiv für Hydrobiologie 121: 497-510.
- SÖKER, H. REHFELDT, K., SANTJER, F., STRACK, M. & SCHREIBER, M. (2000): Offshore Wind Energy in the North Sea. Technical Possibilities and Ecological Considerations - A Study for Greenpeace. <http://archive.greenpeace.org/climate/climatecountdown/dewifinal10.pdf>
- SOTO, M., IRELAND, M. P. & MARIGÓMEZ, I. (2000): Changes in mussel biometry on exposure to metals: implications in estimation of metal bioavailability in 'Mussel-Watch' programmes. The Science of the Total Environment 247: 175-187.
- SPANIER, E. (1994): What are the characteristics of a good artificial reef for lobsters. Crustaceana 67: 173-186.
- SUMER, B. M. & FREDSE, J. (1998): Wave scour around group of vertical piles. ASCE Journal of Waterway, Port, Coastal, and Ocean Engineering 123(5): 248-256.
- SUMER, B. M. & FREDSE, J. (2001): Scour around pile in combined waves and currents. Journal of Hydraulic Engineering 127(5): 403-411.
- SUMER, B. M., FREDSE, J., JENSEN, B. L. & CHRISTIANSEN, N. (2001): Forces on vibrating cylinder near wall in current and waves. ASCE Journal of Waterway, Port, Coastal, and Ocean Engineering 120(3): 233-250.
- SURESH, K., AHAMED, M. S., DURAIRAJ, G. & NAIR, K. V. K. (1993): Impact of power plant heated effluent on the abundance of sedentary organism, off Kalpakkam, east coast of India. Hydrobiologia 268: 109-114.
- UGOLINI, A. & PEZZANI, A. (1992): Learned solar orientation in *Idotea baltica*. Mesogee (Bull. Mus. Hist. Nat., Marseille) 52: 77.
- UNGRUH, G. & ZIELKE, W. (2003): Kolkberechnungen an Offshore-Bauwerken: a state of the art review. Available [www.gigawind.de](http://www.gigawind.de)
- USSENKOW, S. M. (1997): Contamination of harbor sediments in the eastern Gulf of Finland (Neva Bay), Baltic Sea. Environmental Geology 32 (4): 274-280.
- VELLA, G. (2002): The Environmental Implications of Offshore Wind Generation. Available <http://www.utilitiesproject.com>
- VELLA, G., RUSHFORTH, I., MASON, E., HOUGH, A., ENGLAND, R., STYLES, P., HOLT, T. & THORNE, P. (2001): Assessment of the effects of noise and vibration from offshore wind farms on marine wildlife. ETSU W/13/00566/REP DTI/Pub URN 01/1341 submitted to DTI, commissioned by DTI Sustainable Energy Programmes, Available <http://test.netgates.co.uk/nre/pdf.html>
- VERLAQUE, M., GIRAUD, G. & BOUDOURESQUE, C. F. (1981): Effects of a thermal power plant on the Mediterranean marine phytobenthos: the area of high frequency temperature changes. Botanica Marina 24: 69-87.
- VORBERG, R. (2000): Effects of shrimp fisheries on reefs of *Sabellaria spinulosa* (Polychaeta). ICES Journal of Marine Science 57: 1416-1420.
- WALPERSDORF, E., WERNER, U., POLERECKY, L., FRANKE, U., BIRD, P. & DE BEER, D. (2003): Tidal dynamics of O<sub>2</sub>, H<sub>2</sub>S and pH in permeable sands. Berichte – Forschungszentrum Terramare 12: 118-121.
- WANG, J. H., CAIN, S. D. & LOHMANN, K. J. (2003): Identification of magnetically responsive neurons in the marine mollusc *Tritonia diomedea*. The Journal of Experimental Biology 206: 381-388.
- WENDT, P. H., KNOTT, D. M. & VAN DOLAH, R. F. (1989): Community structure of the sessile biota on five artificial reefs of different ages. Bulletin of Marine Science 44: 1106-1122.
- WENNER, E. L., KNOTT, D. M., VAN DOLAH, R. F. & BURRELL, JR., V. G. (1983): Invertebrate communities associated with hard bottom habitats in the South Atlantic Bight. Estuarine Coastal and Shelf Science 17: 143-158.
- WHITEHOUSE, R. J. S. (1998): Scour at Marine Structures. Thomas Telford, 216 p.

- 
- WHO (2005): Electromagnetic fields and public health - Effects of EMF on the Environment *International EMF Project Information Sheet*. Available [http://www.who.int/docstore/peh-emf/publications/facts\\_press/fact\\_english.htm](http://www.who.int/docstore/peh-emf/publications/facts_press/fact_english.htm)
- WILLOWS, A. O. D. (1999): Shoreward orientation involving geomagnetic cues in the nudibranch mollusc *Tritonia diomedea*. *Mar. Fresh. Behav. Physiol.* 32: 181-192.
- WONG C. K., HWANG J. S. & CHEN Q. C. (1998): Taxonomic composition and grazing impact of calanoid copepods in coastal waters near nuclear power plants in northern Taiwan. *Zoological Studies* 37: 330-339
- WOODHEAD, P. M. J. & JACOBSON, M. E. (1985): Epifaunal settlement, the processes of community development and succession over 2 years on an artificial reef in the New York Bight. *Bulletin of Marine Science* 37: 364-376.
- WORZYK, T. & BÖNGELER, R. (2003): Abschätzung der Sedimenterwärmung durch das parkinterne Kabelnetz im Offshore Windpark GlobalTech1. Report by ABB Power Technology Products AB, Karlskrona (Schweden) and Enveco GmbH, Münster commissioned by Nordsee Windpower GmbH & Co. KG, Sulingen, 28 pp.



# Literature Review of Offshore Wind Farms with Regard to Fish Fauna

Oliver Keller, Karin Lüdemann & Rudolf Kafemann

Institute of Applied Fish Biology GmbH

Alter Teichweg 33

22081 Hamburg

[info@fischbiologie.de](mailto:info@fischbiologie.de)

## Contents

<b>1</b>	<b>Summary .....</b>	<b>48</b>
<b>2</b>	<b>Zusammenfassung .....</b>	<b>51</b>
<b>3</b>	<b>Introduction.....</b>	<b>55</b>
<b>4</b>	<b>Topic and Structure of the Report.....</b>	<b>55</b>
<b>5</b>	<b>Review of the Literature of Selected Impact Complexes.....</b>	<b>58</b>
	<b>5.1 Sound and Vibration .....</b>	<b>58</b>
	<b>5.1.1 Construction Phase .....</b>	<b>64</b>
	5.1.1.1 Offshore Wind Farms .....	65
	5.1.1.2 Oil and Gas Exploitation.....	69
	<b>5.1.2 Operational Phase.....</b>	<b>72</b>
	5.1.2.1 Offshore Wind Farms .....	72
	5.1.2.2 Oil and Gas Exploitation.....	77
	5.1.2.3 Sand and Gravel Extraction .....	78
	<b>5.2 Sediment Disturbance.....</b>	<b>78</b>
	<b>5.2.1 Sediment Re-suspension and Turbidity Plumes .....</b>	<b>78</b>
	5.2.1.1 Offshore Wind Farms .....	82
	5.2.1.2 Sand and Gravel Extraction .....	84
	5.2.1.3 Oil and Gas Exploitation.....	86
	<b>5.2.2 Sediment Composition .....</b>	<b>87</b>
	5.2.2.1 Offshore Wind Farms .....	89
	5.2.2.2 Sand and Gravel Extraction .....	89
	5.2.2.3 Oil and Gas Exploitation.....	93
	<b>5.3 Introduction of Hard Substrates .....</b>	<b>93</b>
	<b>5.3.1 Offshore Wind Farms.....</b>	<b>97</b>
	<b>5.3.2 Oil and Gas Exploitation.....</b>	<b>101</b>
	<b>5.4 Electromagnetic Fields .....</b>	<b>105</b>
	<b>5.4.1 Electric Fields.....</b>	<b>106</b>
	5.4.1.1 Offshore Wind Farms .....	107
	5.4.1.2 Magnetic Fields	107
	5.4.1.3 Offshore Wind Farms .....	109
<b>6</b>	<b>Discussion.....</b>	<b>110</b>
<b>7</b>	<b>Conclusions .....</b>	<b>116</b>
<b>8</b>	<b>References .....</b>	<b>118</b>

## 1 Summary

This report comprises a review of the literature on the effects of offshore wind farms on fish. It documents the present state of knowledge by summarising the available results on offshore activities and their impacts on marine fish. Reports of field investigations, conclusions by analogy (fundamental research), and specific research are evaluated. The focus of the literature review is on the North and Baltic Seas, but where necessary also other marine waters are included. Up to now, only few direct investigations on existing wind farms are available. Therefore, other offshore utilisations are also discussed. These are mainly oil and gas exploitation, and sand and gravel extraction. To a certain extent, conclusions by analogy are possible. Four impact complexes are regarded as relevant for fish fauna: (1.) sound and vibration, (2.) sediment disturbance, (3.) introduction of hard substrates, and (4.) electromagnetic fields.

### (1.) Sound and Vibration

The oceans are characterised by a permanent level of **background noise**, caused by wind, waves, currents, precipitation, and such anthropogenic utilisations as shipping. Frequencies below 200 Hz are dominated by shipping noise. Frequencies from about 200 Hz to 10 kHz result from sea surface effects. Background levels in shallow waters are higher than in the open sea.

**Fish hear** in a relatively restricted low frequency range. Many species hear in the range from about 30 Hz to 1 kHz. Additional sensitivities in the infrasonic (<20 Hz) and ultrasonic range (> 20 kHz) are known in some species. Hearing thresholds are frequency-dependant. In marine fish species, threshold values are known between 63 and 103 dB re 1  $\mu$ Pa.

Sound measurements during the **construction** of offshore turbines and other marine structures revealed the highest energies in the low frequency range (about 30 Hz - 2 kHz). This corresponds with the hearing range of fish. From various measurements of piling activities, source levels at a distance of 1 m from the sound source were calculated between 227 and 260 dB re 1  $\mu$ Pa (peak level).

Few investigations deal directly with the **impact of offshore piling noise** on fish. During piling in a British harbour, no behavioural changes or injuries in caged fish were observed. Piling for a bridge in California caused injuries and mortalities in fish.

As a **conclusion by analogy** from related investigations (fundamental research, investigations of seismic shooting), physiological and behavioural effects are considered possible due to the noise of offshore pile driving. Because of the comparable sound levels and the impulsive nature of sound, parallels can be drawn from seismic shooting to piling noise. The risk of mortalities is considered to be low. Injuries (tissue disruption, swim bladder damage, damage to blood cells, inner bleedings, eye injuries), deafness (TTS), or damage to the sensoric epithelium of the inner ear are possible. Other potential effects include stress responses. The probability of behavioural reactions is considered highest among all possible effects. Avoidance and flight reactions, alarm response, and changes of shoaling behaviour are the possible results, further impacts on distribution, local abundance and catch rates. Masking of intraspecific communication is possible in tonal species, such as the gadoids.

The **emissions of wind turbines during the operational phase** are known for single turbines with capacities of between 500 kW and 2 MW. Relevant emissions occur in the low-frequency range (about 20 Hz to 1 kHz). Considerable variations were observed.  $L_{eq}$ -levels in  $1/3$  octave bands were registered between 102 and 125 dB re 1  $\mu$ Pa. For

the future wind turbines of approx. 5 MW, extrapolations predict continuous sound levels of up to 150 dB re 1  $\mu$ Pa.

The only investigation to date to deal directly with the **impact of wind turbines** on fish suffers from a lack of reference studies. Therefore, possible avoidance reaction has not been satisfactorily demonstrated. No other investigations of the effects of long term continuous sound emissions on fish exist. Thus, predictions for the operational phase are prone to more uncertainties than for the construction period.

On the basis of **conclusions by analogy**, it is assumed that the operational noise of offshore wind farms might cause behavioural reactions (avoidance) in fish. Masking of intraspecific communication is considered especially severe during the spawning season. An important issue for future investigations is to establish whether fish habituate to the operational sound of wind turbines.

## (2.) Sediment disturbance

The sensitivity of fish to **suspended sediment** is species and life stage specific, and depends on abiotic factors of the sediment, sediment concentration, and duration of exposure. Fish larvae are more sensitive to suspended sediments than eggs, juvenile or adult fish. Planktonic larvae react with reduced growth rates up to mortalities. Suspended sediment may make pelagic eggs sink to the bottom. Demersal eggs may also be affected. Increased mortality rates and reduced breeding success are possible effects. Visual feeders, especially planktonic feeders, may be affected. Avoidance and flight behaviour have been observed. Coarse particles may lead to skin injuries. Fine sediments can clog the gills and cause suffocation. Light limitation caused by suspended fine particles may affect phytoplankton growth, and thus organisms higher in the food web. Fish species that depend on certain characteristics of the bottom substrate might be affected by changes in sediment composition. Possible effects are a decrease in reproductive success, or food limitation for benthic feeders.

**Specific Investigations** at Horns Rev revealed that the sediment composition was unchanged after the construction of the wind farm. No increase in the fine corn fraction was observed. No decrease in the sandeel abundance was found.

An indirect approach by means of a **computer simulation** revealed that high gravity foundations and monopile ramming cause fewer sediment plumes, thus minor disturbance is assumed, compared to low gravity foundations. Drilling and sluicing of a monopile will cause larger sediment plumes, but for a shorter duration. Construction works of a low gravitation foundation will cause sediment concentrations of more than 10 - 15 mg/l only in the direct vicinity of the digging area. No lethal impacts on fish were expected. Temporary effects on pelagic eggs and larvae were predicted in the immediate vicinity of construction activities, together with smaller effects on demersal eggs and larvae. For juvenile or adult fish, flight or avoidance behaviour is assumed.

**Sand and gravel extraction** cause higher sediment loads of up to 5000 mg/l in the direct vicinity of the dredger, therefore a higher effect level is to be expected. Thus, results from those investigations are not fully transferable to the construction of wind turbine foundations. Sediment concentrations rapidly decrease with increasing distance from the source. Only the smaller fractions are transported over longer distances.

Tolerance thresholds for demersal fish were assumed to be > 10 mg/l. Short term effects of the construction of a **gas pipeline** were predicted during the construction phase for fish species using the area as spawning or breeding habitat. Effects on demersal fish eggs and larvae were considered possible. No effects on adult specimens

were expected. Effects of sediment changes by oil platforms and bridge foundations on the benthic community were documented, along with changes of grain size distribution. No specific investigations on the impact on fish were undertaken.

### **(3.) Introduction of Hard Substrates**

Artificial reefs are highly attractive to fish and cause significant increases in catch rates. Fish populations on artificial reefs resemble those from natural hard substrates. Fish biomass consists mainly of migrating species. Colonisation is affected by the substrate, shape, size, and height of a reef. The attraction effect increases with the reef size. The greater its complexity, the more effective it is for fish. Reef height is important to migrating pelagic species at water depths of > 40 m. The horizontal spread of a reef is important for stationary demersal species. Typical ranges of influence of artificial reefs were determined in the range of hundreds of meters.

**Specific investigations at offshore wind farms** state that steel monopile foundations lead to higher diversities and abundances in the direct vicinity of the turbines. However, significantly less attraction was assumed for the monopile structure than for scour protection. The vertical dimension of the foundation would attract gadoid fish, while the attraction of flatfish would stem from the scour protection. Higher densities in connection with turbine foundation were found in one of four transects. Fish were attracted by the wind farm beyond a distance of 500 m.

**Conclusions by analogy** from investigations of oil and gas platforms lead to the assumption that the reef effect is greater in shallow homogeneous environments than in more heterogeneous regions. Steel structures with high complexity are more attractive than concrete foundations. The highest densities were often observed in the range of some hundreds of metres from the platform. The vertical profile of the platform was of varying importance for the different developmental stages of fish.

### **(4.) Electromagnetic Fields**

Electric fields are used by electro-sensitive species for prey detection, spatial orientation, and probably for navigation. The lowest thresholds for electric fields have been found for elasmobranchs and lampreys. Possible reactions are behavioural responses. Magnetic fields are used by fish for navigation during migration. Possible effects of electric fields are disturbance of orientation, scaring reaction, redirection and torpidity. Threshold values of fish depend on field strength, specific sensitivity of the species, and size of the individual. Definite reactions of changes in the magnetic field were only proven for very high field strengths. Tagging experiments showed no permanent barrier effect due to cables.

Preliminary **specific investigations for offshore wind farms** resulted in avoidance behaviour as well as attraction in elasmobranchs, depending on field strength. Simulations of the field strengths of typical sea cables resulted in values in a range in which elasmobranchs are both attracted and scared off. Field investigations showed no definite changes in the behaviour of silver eels, but disturbance within a distance of less than 500 m could not be excluded. Danish investigations found no significant differences between the pre-operational and operational phases, when the distribution of selected fish species was observed in relation to a cable of the power grid connection.



## 2 Zusammenfassung

Die vorliegende Literaturstudie stellt den gegenwärtigen Kenntnisstand über die Effekte von Offshore Windenergieanlagen (WEA) auf die marine Fischfauna zusammen. Die verfügbaren Ergebnisse zu Auswirkungen verschiedener Offshore-Aktivitäten auf die Fischfauna werden dokumentiert. In die Studie einbezogen wurden Berichte über Felduntersuchungen, Analogieschlüsse (basierend auf Ergebnissen der Grundlagenforschung) und spezifische Untersuchungen. Der räumliche Schwerpunkt der Zusammenstellung liegt auf der Nord- und Ostsee, wird aber durch Ergebnisse aus anderen Gewässern ergänzt. Bislang wurden nur wenige Untersuchungen an bereits bestehenden Windparks durchgeführt. Daher werden im vorliegenden Bericht auch Auswirkungen anderer Offshore-Nutzungen dargestellt. Dies sind im Wesentlichen die Öl- und Gasförderung sowie der Sand- und Kiesabbau. In einem gewissen Ausmaß sind Analogieschlüsse auf Offshore Windparks möglich. Vier Wirkkomplexe wurden identifiziert, die als relevant für die Fischfauna erachtet werden: (1.) Schall und Vibrationen, (2.) Sedimenteingriffe, (3.) Künstliches Hartsubstrat und (4.) Elektromagnetische Felder.

### (1.) Schall und Vibrationen

Im Meer herrscht durch die Wirkung von Wind, Wellen, Strömung, Niederschläge und anthropogene Nutzungen wie z.B. Schifffahrt ein permanenter **Hintergrundschall**. Der Frequenzbereich unterhalb von 200 Hz wird von Schiffsgeräuschen dominiert. Die Frequenzen etwa zwischen 200 Hz und 1 kHz werden von Effekten der Meeresoberfläche verursacht. Die Hintergrundwerte sind in flachen Küstengewässern höher als im offenen Meer.

**Fische hören** in einem relativ schmalen niederfrequenten Bereich. Viele Fischarten hören im Bereich etwa zwischen 30 Hz und 1 kHz. Empfindlichkeiten im Infraschall (<20 Hz) und Ultraschallbereich (>20 kHz) sind für einige Arten nachgewiesen. Frequenzabhängig sind Hörschwellen bei marinen Fischen zwischen 63 und 103 dB re 1  $\mu$ Pa bekannt.

Schallmessungen in der **Konstruktionsphase von Offshore WEA** und anderen marinen Bauwerken zeigten die Emission höchster Energien im niederfrequenten Bereich (etwa 30 Hz - 2 kHz). Dieser Frequenzbereich überschneidet sich mit dem Hörspektrum von Fischen. Aus Messungen bei Rammarbeiten zu verschiedenen Offshore Fundamenten wurden Quellschallpegel in einer Entfernung von 1 m von der Schallquelle zwischen 227 und 260 dB re 1  $\mu$ Pa (peak-Level) errechnet.

Nur wenige **Untersuchungen** haben sich **direkt** mit den Auswirkungen des Schalls von Offshore Rammarbeiten auf Fische beschäftigt. Während der Rammarbeiten in einem englischen Hafen wurden keine Verhaltensreaktionen oder Verletzungen bei Fischen beobachtet. Rammarbeiten für eine Brücke in Kalifornien verursachten Verletzungen und Mortalitäten bei Fischen.

**Analogieschlüsse** aus sachverwandten Untersuchungen (Grundlagenforschung, seismische Erkundungen) lassen physiologische und Verhaltensreaktionen auf die Geräuscheinträge bei Offshore Rammarbeiten erwarten. Bedingt durch den vergleichbaren Schallpegel und den ebenfalls impulsartigen Charakter des Schalls lassen sich Rückschlüsse von seismischen Erkundungen auf Rammschall ziehen. Das Risiko von Mortalitäten wird als gering eingeschätzt. Verletzungen (Geweberisse, Verletzungen der Schwimmblase, der Blutzellen, innere Blutungen oder Blutungen im Auge), Schwerhörigkeit (Temporäre Hörschwellenverschiebung) oder Schädigungen des sensorischen Epithels des Innenohrs können auftreten. Als weitere Effekte können

Stressreaktionen auftreten. Von allen möglichen Effekten wird die Wahrscheinlichkeit des Auftretens von Verhaltensreaktionen am höchsten eingeschätzt. Vermeidungs- und Fluchtreaktionen, Alarmreaktionen und Änderungen des Schwarmverhaltens können eintreten, mit weiteren Folgen für das Vorkommen, die lokale Verteilung und die Fangraten. Weiterhin kann es bei Arten mit Lautäußerungen, wie z.B. den Gadiden, zur Maskierung der zwischenartlichen Kommunikation kommen.

Die **Emissionen von WEA im Betriebszustand** wurden für einzelne Anlagen mit Kapazitäten zwischen 500 kW und 2 MW ermittelt. Relevante Schallanteile liegen im niederfrequenten Bereich (20 Hz bis 1 kHz). Es wurden erhebliche Variationen beobachtet. Äquivalente Dauerschallpegel ( $L_{eq}$ ) im 1/3 Oktav Spektrum wurden zwischen 102 und 125 dB re 1  $\mu$ Pa bestimmt. Für die Schallabstrahlung der zukünftigen Generation von WEA mit Kapazitäten um 5 MW sagen Extrapolationen gemittelte Dauerschallpegel von bis zu 150 dB re 1  $\mu$ Pa vorher.

In der bislang einzigen Untersuchung, die direkt die **Auswirkung von WEA** auf Fische untersucht hat, konnte aufgrund der fehlenden Erfassung des Referenzzustandes eine mögliche Vermeidungsreaktion nicht sicher nachgewiesen werden. Es liegen keine anderen Untersuchungen der Auswirkung langfristiger Dauerschallemissionen auf Fische vor. Daher unterliegt die Auswirkungsprognose für die Betriebsphase größeren Unsicherheiten als die der Bauphase.

Auf der Grundlage von Analogieschlüssen wird vermutet, dass die Betriebsgeräusche von Offshore WEA Verhaltensreaktionen (Vermeidung) auslösen können. Die Maskierung der zwischenartlichen Kommunikation stellt insbesondere in der Laichzeit einen weiteren potenziellen Effekt dar. Ein wichtiger Gesichtspunkt in zukünftigen Untersuchungen ist die Frage, ob eine Gewöhnung (Habituation) an die Geräusche während des WEA Betriebs stattfindet.

## **(2.) Sedimenteingriffe**

Die Sensibilität von Fischen gegenüber suspendiertem Sediment ist artspezifisch und abhängig von der jeweiligen Lebensphase. Sie wird von abiotischen Eigenschaften des Sediments, der Konzentration und der Expositionszeit beeinflusst. Fischlarven reagieren empfindlicher gegenüber suspendiertem Material als Eier, juvenile oder adulte Fische. Planktische Larven zeigen Reaktionen von vermindertem Wachstum bis zur Mortalität. Suspendiertes Material kann sich auf pelagischen Eiern ablagern und dazu führen, dass sie zu Boden sinken. Auch demersale Fischeier können beeinträchtigt werden. Mögliche Auswirkungen sind erhöhte Mortalitätsraten oder ein reduzierter Bruterfolg. Effekte können bei visuellen Futtersuchern, insbesondere mit planktischer Ernährung, auftreten. Auch Vermeidungs- und Fluchtreaktionen wurden beobachtet. Grobkörnige Partikel können sogar zu Hautverletzungen führen. Feinkörnige Sedimente verkleben die Kiemen und führen zur Erstickung. Lichtlimitierung, die durch suspendierte Sedimente in der Wassersäule verursacht wird, kann das Wachstum des Phytoplanktons beeinträchtigen und so auch Auswirkungen auf Organismen haben, die höher im Nahrungsnetz stehen. Fischarten, die auf bestimmte Sedimenteigenschaften des Bodensubstrates angewiesen sind, können durch eine Veränderung der Sedimentzusammensetzung geschädigt werden. Mögliche Effekte sind eine Verminderung des Reproduktionserfolges oder eine Nahrungs-limitierung für Arten, die sich benthisch ernähren.

**Spezifische Untersuchungen** im Windpark Horns Rev zeigten, dass sich die Sedimentzusammensetzung nach Errichtung der Anlagen nicht verändert hatte. Es wurde keine Erhöhung der Feinkornfraktion beobachtet. Auch die Dichten von Sandaalen waren unverändert.

Ein indirekter Ansatz über eine Computersimulation ergab, dass die Errichtung hoher Schwergewichtsfundamente und das Rammen von Monopiles für Offshore Windparks zu geringeren Auswirkungen führt als die Errichtung niedriger Schwergewichtsfundamente. Das Bohren oder Einspülen von Monopiles verursacht größere Trübungsfahnen, jedoch für einen Zeitraum. Die Konstruktionsarbeiten für ein niedriges Schwergewichtsfundament verursachen Sedimentkonzentrationen von mehr als 10 - 15 mg/l nur in der direkten Umgebung der Bohrarbeiten. Es werden keine tödlichen Folgen für Fische erwartet. Zeitweilige Auswirkungen auf pelagische Eier und Larven werden voraussichtlich in der direkten Umgebung der Konstruktionsarbeiten eintreten, einhergehend mit geringeren Auswirkungen auf demersale Eier und Larven. Für juvenile und adulte Fische muss mit Flucht oder anderen Verhaltensreaktionen gerechnet werden.

Bei der **Sand- und Kiesgewinnung** werden höhere Sedimentfrachten von bis zu 5000 mg/l in der direkten Umgebung der Dredge erzeugt, so dass insgesamt stärkere Auswirkungen zu erwarten sind. Daher besteht nur eine eingeschränkte Übertragbarkeit auf die Auswirkungen von Konstruktionsarbeiten für Offshore Windparks. Die Sedimentkonzentrationen sinken mit zunehmender Entfernung zur Quelle. Nur die Feinkornfraktion wird über größere Entfernungen transportiert.

Grenzwerte wurden für demersale Arten mit <10 mg/l angenommen. Kurzzeitige Auswirkungen wurden während der Konstruktionsphase einer Gas-Pipeline für Fischarten vorhergesagt, die das Gebiet als Laichplatz oder Nahrungsgrund nutzen. Auswirkungen auf demersale Eier und Larven wurden für möglich gehalten, wohingegen keine Effekte auf adulte Individuen erwartet wurden.

Auswirkungen von Sedimentveränderungen als Folge der Konstruktion von Ölplattformen und Brückenfundamenten auf die benthische Fauna dokumentiert, ebenso wie Änderungen der Korngrößenzusammensetzung. Eigene Untersuchungen der Auswirkungen auf die Fischfauna wurden jedoch nicht durchgeführt.

### **(3.) Künstliches Hartsubstrat**

Künstliche Riffe weisen eine hohe Attraktivität auf Fische auf und führen zu signifikant erhöhten Fangquoten. Die Fischgemeinschaften künstlicher Riffe gleichen denen natürlicher Hartsubstrate. Die Fischbiomasse besteht vor allem aus wandernden Arten. Die Besiedlung wird von dem Substrat, der Form, der Größe und der Höhe eines Riffs beeinflusst. Die Attraktionswirkung steigt mit zunehmender Riffgröße. Je höher die Komplexität der Struktur, desto effektiver ist sie für Fische. Die Riffhöhe ist in Wassertiefen von > 40 m bedeutend für pelagische Arten. Die horizontale Ausdehnung des Riffs ist wichtig für stationäre demersale Arten. Die Ausdehnung typischer Einflusszonen künstlicher Riffe wurde im Bereich einiger Hundert Meter ermittelt.

**Spezifische Untersuchungen** an Offshore Windparks ergaben höhere Diversitäten und Abundanzen in der direkten Umgebung von Monopile Fundamenten aus Stahl. Eine höhere Attraktionswirkung wurde von den Steinschüttungen zum Kolkschutz verursacht. Die vertikale Ausdehnung würde anziehend auf dorschartige Fische (Gadiden) wirken, wohingegen die Kolkschutz Plattfische anziehen. Höhere Dichten im Bereich der WEA Fundamente wurden in einem von vier Transekten nachgewiesen. Fische wurden von dem Windpark in einem Bereich von über 500 m angezogen.

Analogieschlüsse aus Untersuchungen von Öl- und Gasförderplattformen führen zu der Annahme, dass der Riffeffekt in flachen einheitlichen Gebieten größer ist als in heterogenen Umgebungen. Komplexe Stahlstrukturen lösen einen höheren Attraktionseffekt aus als Schwergewichtsfundamente. Hohe Dichten wurden oft im Bereich von mehreren Hundert Metern von der Plattform gefunden. Das Vertikalprofil der Plattform weist unterschiedliche Bedeutung für die verschiedenen Lebensstadien von Fischen auf.

#### **(4.) Elektromagnetische Felder**

Elektrische Felder werden von elektro-sensiblen Arten zum Beuteerwerb, zur räumlichen Orientierung und möglicherweise zur Navigation genutzt. Die niedrigsten Schwellenwerte wurden bei Haien und Rochen sowie Neunaugen gefunden. Als mögliche Auswirkungen treten Verhaltenreaktionen auf. Magnetfelder werden von Fischen für die Navigation während ihrer Wanderbewegung verwendet. Potenzielle Auswirkungen von elektrischen Feldern auf Fische bestehen in Störungen der Orientierung, Abschreckung, Ablenkung und Umlenkung sowie Betäubung. Die Schwellenwerte sind abhängig von der Feldstärke, der artspezifischen Empfindlichkeit und der Größe des Individuums. Eindeutige Reaktionen auf Veränderungen des Magnetfeldes wurden nur für sehr hohe Feldstärken nachgewiesen. Markierungsexperimente ergaben keinen dauerhaften Barriereeffekt als Folge eines elektrischen Kabels.

Vorläufige **spezifische Untersuchungen an Offshore Windparks** zeigten in Abhängigkeit von der Feldstärke sowohl Vermeidungsreaktionen als auch anlockende Effekte bei Haien und Rochen. Simulationen der Feldstärke typischer Seekabel ergaben Werte, die sowohl zur Anlockung als auch zur Abschreckung führen. Felduntersuchungen zeigten keine eindeutige Verhaltensänderung bei Blankaalen, jedoch konnten Störungen im Bereich von 500 m um die Anlage nicht ausgeschlossen werden. Dänische Untersuchungen zeigten keinen Einfluss des Kabels zur Netzanbindung auf die Verteilung ausgewählter Arten im Vergleich der Phase vor dem Betrieb mit der Betriebsphase.

### 3 Introduction

The development of concepts for offshore wind farms in the North and Baltic Seas has increased significantly in recent years. This has been accompanied by new insights into the ecological impacts which offshore wind farms could have on the marine environment. Contributions to this knowledge have been made by investigations carried out by project applicants in order to obtain the necessary licenses, and by publicly funded research projects. Particularly concomitant research on ecological aspects of offshore wind farms which have since been installed in northern European coastal waters has extended the knowledge base. However, these insights are still few compared to those available for on-shore sites (ZUCCO & MERCK 2004). This applies especially to project induced effects on fish fauna and benthic biocoenosis, because these have drawn less attention from scientific researchers than birds or marine mammals (ZUCCO & MERCK 2004).

Against this background, the available results of offshore activities and their impacts on the marine fish fauna are summarised and thematically processed. The report is based on an evaluation of international and national articles, reports and other sources of information. An important base is the evaluation of general fish biological as well as species specific knowledge of sensitivities to disturbances.

An important objective of this report is the documentation of the present state of knowledge regarding the effects of anthropogenic activities in the North and Baltic Seas on the marine fish fauna. A further important objective is to point out future needs for research based on the identified gaps in knowledge. This will ultimately lead to a better evaluation of wind farm induced impacts on fish fauna.

### 4 Topic and Structure of the Report

The basis of information on impacts of offshore wind farms on fish is still very limited. To date, no systematic review of the direct effects of offshore wind farms on fish has been carried out. The planning and construction of offshore wind farms is still a relatively young branch of industry. Most of the projects applied for have not yet been realised, but are still in the planning phase. Thus, only few direct investigations at wind farms exist. The available studies are partly limited to investigations on single turbines, which are much smaller than the ones currently planned (SMITH & WESTERBERG 2003). To date, concomitant research has focused in particular on organism groups such as birds or marine mammals, whereby the amount of existing fish faunistic investigations is still limited. In addition, the available information can only partially be generalised or transferred to other projects. This is due to different location-specific or technological conditions of turbines, which always have to be taken into account when conducting field investigations. Often the survey results are not comprehensive enough, because they suffer from a lack of comparative studies on adequate reference areas, or from the absence of basic investigations made before the construction or operation of the turbines.

This report does not claim completeness. This is due to the fact that much information and experience in the innovative and dynamic field of research regarding effects that offshore projects may have on the marine environment is either not yet published or available only in the form of "grey literature". Therefore, the information cannot be found in literature databases or any other conventional tracing file. In order to keep information

deficits as small as possible, the attempt has been made to complete the investigation via personal contacts with various scientists or scientific institutions. Figure 1 gives an overview of the sources of information used for the present literature review.

The review summarises sources of different levels of expressiveness regarding the evaluation of wind farm induced effects on fish. It is necessary to distinguish between:

- Reports of field investigations which contain specific information on the impacts of various utilisations on fish (without conclusion by analogy).
- Sources which forecast impacts various utilisations will have on fish, on the basis of conclusions by analogy.
- Sources which provide information on physiological, ethological and ecological parameters or sensitivities of particular species (fundamental research), and can thus be used for the forecast of possible impacts.

The sources compiled in the present literature review were filed in a database system (Reference Manager<sup>®</sup> version 11; Figure 1). Besides the literature cited in this report, the database includes a comprehensive summary of other publications which, by title or abstract (if mentioned), were regarded as possibly helpful for evaluating the impacts of offshore projects on fish. This involves primarily basic research containing information on biological and ecological characteristics of particular species, but has not been cited in the project specific sources.

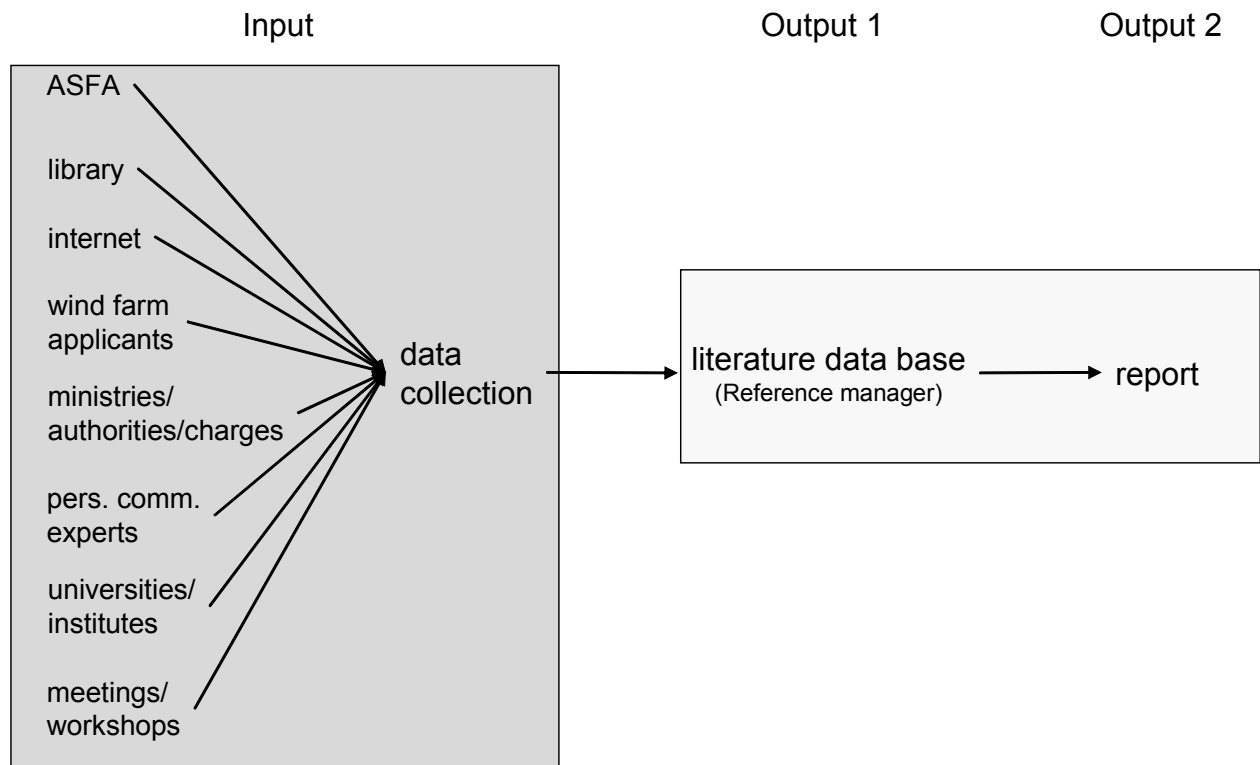

Figure 1: Schematic overview of literature study and data processing

The geographic and species specific focus of the literature review is on the North and Baltic Seas. As a result of the low density of information, those sources which refer to other waters and their inherent species have also been evaluated. In the present report, impact complexes are investigated which are regarded as relevant for fish fauna. These include:

- Sound and vibration (Chapter 5.1)
- Sediment disturbance (Chapter 5.2)
- Introduction of hard substrates (Chapter 5.3)
- Electromagnetic fields (Chapter 5.4)

The literature evaluation is not limited to offshore wind farms, but includes other types of utilisation in the North and Baltic Seas, as they might contribute to a better understanding of wind farm induced effects on fish fauna. The focus is on:

- Offshore wind farms
- Oil and gas exploitation
- Sand and Gravel extraction.

Subsequently, this report deals with each of the impact complexes listed above in a separate chapter. In the first instance, the question of whether the impact complexes discussed are reasonably broken down into separate subdivisions (e.g. acoustic disturbance, distinguished by construction noise and operational noise), or whether they are to be addressed as unities, is to be analysed. Subsequently, the biological information on the reaction of fish upon the impact complex discussed which have been demonstrated in the corresponding literature is given in an introductory manner.

The available project-specific information on the particular types of utilisation has been textually processed, based on the background information given above. In cases with information deficits, parallels to other relevant investigations have been established in order to refer to the possibility of conclusions by analogy. Negative as well as positive effects on fish fauna have been discussed.

## 5 Review of the Literature of Selected Impact Complexes

### 5.1 Sound and Vibration

Usually, literature dealing with the impacts of sound on fish covers a broad range of topics. Besides an introduction to the basics of sound physics, this usually covers definitions and formulas on the spreading and attenuation of sound waves in water (KNUST et al. 2003, DEWI 2004, NEDWELL & HOWELL 2004, WAHLBERG & WESTERBERG 2005). For further information on these topics, we refer to those studies.

#### Ambient noise

In the sea there is a permanent level of ambient background noise caused by wind, waves, and currents. Towards the low-frequency range, the background values increase considerably, rising with increasing wind speeds and wave heights (Figure 2, Figure 3). While this correlation is widely observed, NEDWELL et al. (2003) found higher background levels along with lower wind speeds in typical shallow wind farm areas. It was not possible to unequivocally determine the reason for this unexpected feature, but the authors considered it possible that in shallow waters, rolling waves at the higher wind speeds drive bubbles into the water. These have a well documented action in attenuating the propagation of noise, and would hence tend to reduce the background noise.

In describing wind farm locations, the term “shallow water” is frequently used. However, this is a subjective term. For instance, references to shallow water noise in the underwater acoustics literature typically result from military interest and refer to water depths in the order of 200 m. Therefore, NEDWELL et al. (2003) sought a description of the typical location of wind farms, and proposed the term “shoals” to describe such locations.

The ambient noise is not only caused by wind, waves, or currents, but also by precipitation and such anthropogenic utilisations as shipping. Ships often produce sounds with local maxima of 20 Hz to 100 Hz (WENZ 1962, URICK 1983, COLLIER, 1997 in: DEWI 2004). Measurements at Scroby Sands and North Hoyle, GB (NEDWELL et al. 2003) revealed significantly greater variations during daytime, attributable to the higher number of short, local ship movements in coastal waters on working days. Frequencies below 200 Hz were dominated by shipping noise, whereas frequencies from about 200 Hz to 10 kHz resulted from sea surface effects and showed little variability (NEDWELL et al. 2003). Near the North Hoyle wind farm, a high source level (SL) of 195 dB re 1  $\mu$ Pa at 1 m was caused by a nearby oil and gas platform (NEDWELL et al. 2003).

Compared to the open sea, background levels in shallow waters are about 10 dB higher (URICK 1983 in: DEWI 2004, NEDWELL et al. 2003). The acoustic background level in the North Sea is approx. 80 dB re 1  $\mu$ Pa. Under the effects of local shipping noise, levels up to 100 dB re 1  $\mu$ Pa are observable (THIELE 2002, DEWI 2004). Background noise in the North Sea tends to be higher than in the Baltic Sea. The difference amounts to 10 - 20 dB, depending on frequency (DEWI 2004).

Due to increasing anthropogenic utilisation, the oceans are louder now than they were some decades ago. In the Pacific Ocean (Point Sur, California) between the 1960s and the 1990s, an increase in ocean ambient sound of about 10 dB was registered in the low frequency range (80 Hz to 100 Hz). The authors attributed this to ship traffic



(ANDREWS et al. 2002). Other anthropogenic sources of noise include sonar, fishery, oil drilling, seismic explorations, and also wind farms.

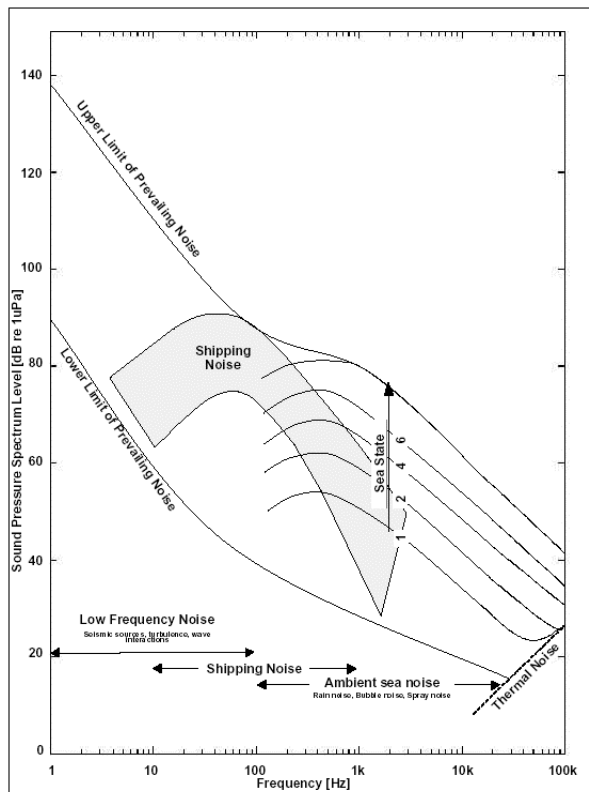

Figure 2: Background noise (from NEDWELL & HOWELL 2004, adapted from WENZ 1962).

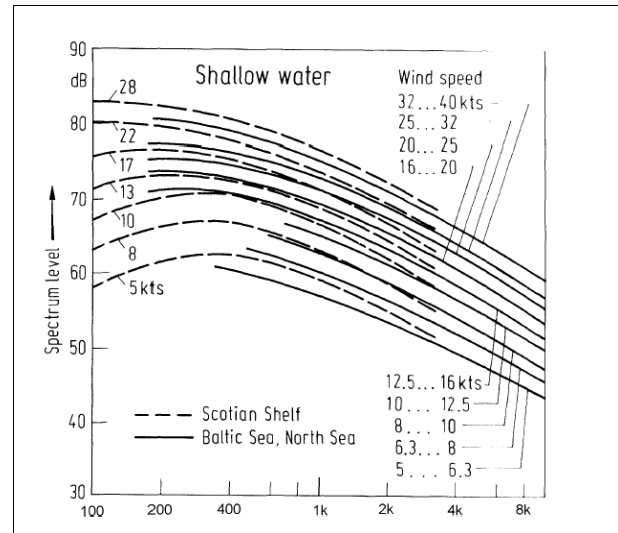

Figure 3: Background noise in relation to wind speed (unit: dB re  $1\mu\text{Pa}$ ) (from THIELE 2002).

### Sound perception by fish

Fish perceive sound in different ways. The lateral line organ reacts to particle displacement of the water. The receptors (neuromasts) are connected directly to the outside environment by canal pores. They respond to very low-frequency oscillations of less than 200 Hz. In a pressure gradient, they react by comparing the reactions of different hair cells (BONE & MARSHALL 1985). The lateral line organ serves primarily to perceive water movements relative to the fish's body (SAND 1984, ENGER et al. 1989). Higher frequencies are perceived by the inner ears. Each otolith organ consists of a small calcareous stone which is located on a sensory epithelium, surrounded by endolymph. Sound pressure waves induce deflections of the sensory hair cells by means of shear stress between the otolith and the sensory epithelium. The deflections are deduced in the form of receptor potentials. Fish with a close association between the swim bladder and the ear are primarily sensitive to sound pressure, while those lacking gas filled cavities are sensitive to particle motion (ICES 2005).

Generally, the distinction is between hearing generalists and hearing specialists (FAY & POPPER 1998). Hearing generalists react insensitively to frequencies of more than 1 kHz, but they hear well in a narrow low-frequency range. They have lower sensitivities than hearing specialists. There are generalists with a swim bladder as well as without. It is assumed that the presence of a swim bladder increases the hearing capacity. The gas-filled swim bladder is more compressible than water and acts as a "pressure

fluctuation transducer” that transmits the sound-induced pressure fluctuation via the endolymph to the otoliths. There, deflections of the hair cells are eventually induced (BONE & MARSHALL 1985). The hearing capacity of hearing generalists decreases rapidly above 100 Hz because these frequencies hardly cause any movement in the otoliths, so that species without a swim bladder are practically deaf to frequencies above 250 Hz (WESTERBERG 1993 in: ENGELL-SØRENSEN & SKYT 2002). Species with a swim bladder, but with no other specialisations for sound conduction, can hear in a range up to about 500 Hz (WESTERBERG 1993 in: ENGELL-SØRENSEN & SKYT 2002). Hearing specialists have specialisations for linking the swim bladder to the inner ear (e.g. Weberian ossicles of the ostariophysi, bulla auditoria of the clupeidae) and basically react to pressure fluctuations. Experiments have also shown that fish can distinguish sounds coming from different directions (ENGER et al. 1973, HAWKINS 1973), although the auditory mechanisms that permit this are poorly understood (ICES 2005).

Fish hear in a lower frequency range than marine mammals (NEDWELL & HOWELL 2004). Fish are sensitive to a rather restricted range of frequencies compared with terrestrial animals (ICES 2005). While many fish species hear in the range of about 30 Hz to 1 kHz (Figure 4), some investigations have proven species specific hearing abilities in the infrasonic range of less than 20 Hz (KARLSEN 1992, KNUDSEN 1997, SAND et al. 2000), and in the ultrasonic range of about 20 kHz (MANN et al. 1998, POPPER et al. 2004). Sensitivities in the ultrasonic range have possibly been developed in the course of evolution as an adaptation to the echo-location of whales and dolphins as predators of that fish species (ASTRUP & MØHL 1993, MANN et al. 1998). Recent investigations reveal that not all herring-like species (Clupeidae) are able to hear in the ultrasonic range. This capacity is probably restricted to the subfamily Alosinae (shads). However, the hearing range of the herring-like species which cannot perceive ultrasound reaches frequency ranges of about 4 kHz, which justifies their classification as hearing specialists (MANN et al. 2001).

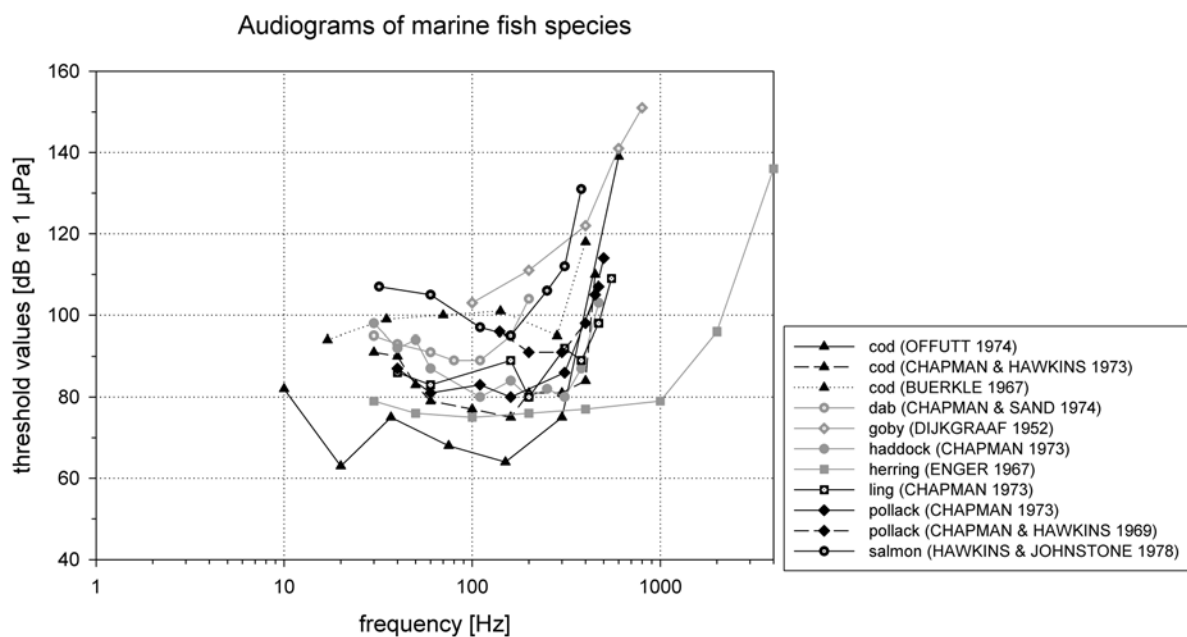

Figure 4: Audiograms of marine fish species (from NEDWELL et al. (2004), adapted)

Results regarding the hearing threshold and hearing range are available for the following marine fish: plaice and dab (CHAPMAN & SAND 1974, KARLSEN 1992), cod (BUERKLE 1967, CHAPMAN & HAWKINS 1973, OFFUTT 1974, SAND & KARLSEN 1986, ATRUP & MØHL 1993), salmon (HAWKINS & JOHNSTONE 1978), black goby (DIJKGRAAF 1952), herring (ENGER 1967), and pollack and ling (CHAPMAN 1973) (Figure 4). NEDWELL et al. (2004) summarise a great number of fish and mammal audiograms and present them in a standardised form.

Fish audiograms are obtained in various ways. By means of classical conditioning technique, the test animal is taught a certain behavioural reaction (e.g. change of body position) as a response to a sound stimulus. ECG measurements of the electrical potentials produced by perceiving the sound stimulus is done via subcutaneously or cutaneously placed electrodes (NEDWELL et al. 2004). Another common procedure to determine the hearing curve of fish is the measurement of conditioned changes of heartbeat frequency (e.g. CHAPMAN & SAND 1974, KARLSEN 1992). Recently, the ABR technique (Auditory Brainstem Response) has been adapted to fish. Reactions to sound are recorded with cutaneous electrodes (KENYON et al. 1998, CASPERS et al. 2003). By using the ABR method, the time required for testing can be reduced from several months (in behavioural testing) to some days, and no invasive surgery is necessary. However, the knowledge of the audiogram does not allow any conclusion regarding the impact the sound stimulus will have on the behaviour of the fish.

### Types of effect

Underwater noise may have effects on fish when the frequency and sound level of the sound overlap with the hearing ability of the fish species in question, and when the sound level exceeds the ambient background noise. In addition, the audibility of a signal is influenced by the signal to noise ratio (S/N ratio).

The neural perception of acoustic signals is integrated in concrete frequency bands ("critical bands"), which play the role of a frequency filter. In mammals, sounds within one critical band are represented on the same region on the basilar membrane. The band width of the critical bands depends on the species as well as on the frequency under consideration. Investigations of critical bands and critical ratios (ratio of signal intensity to noise intensity [dB]) exist e.g. for cod (*Gadus morhua*). Summarised, the critical ratio is in the range of 19 - 24 dB in the "good hearing range" of cod (BUERKLE 1968, CHAPMAN & HAWKINS 1973). With a slightly different method, BUERKLE (1969) calculated the critical ratio at 35 Hz as 20.6 dB. and at 70.7 Hz as 22.8 dB. In other words, in order to be audible, pure tones of 35.3 Hz resp. 70.7 Hz have to be 20.6 dB resp. 22.8 dB louder than the background noise in the critical band. TAVOLGA (1974) raises the question of whether the concept of critical bands, which is adapted from mammalian hearing, is applicable to fish. As a result of the variety of hearing systems in fish, the ability for frequency discrimination might be restricted to some taxonomic groups.

After NEDWELL et al. (2003), the effects of noise on fish can include:

- **primary effects**, such as immediate or delayed fatal injury of animals near powerful sources
- **secondary effects**, such as injury or deafness, which may have long-term implications for survival
- **tertiary (behavioural) effects**, such as avoidance of the area.

Threshold values of 180 to 220 dB re 1  $\mu$ Pa for physical damage in fish are given by EVANS (1998) in a study of marine mammals. The same author specifies threshold values for avoidance behaviour as 160 to 180 dB re 1  $\mu$ Pa. However, these values can only be taken as indications because a possible harmful effect depends on the species-specific hearing capacity. This fact is taken into account by the  $\text{dB}_{\text{ht}}(\text{species})$  theory (ht = hearing threshold) (NEDWELL et al. 2003, NEDWELL & HOWELL 2004). Sounds are filtered in a way that corresponds to the respective hearing ability. The sound level filtered corresponds to the degree of sound perception in the species under consideration (NEDWELL et al. 2003). Derived from human hearing, it was assumed that sound levels of 90 dB above the hearing threshold lead to significant avoidance reactions, with mild behavioural reactions occurring at 70 dB above the threshold (NEDWELL & HOWELL 2004).

### Physiological effects

The impact of acoustic disturbance depends not only on the mean sound level (effective value  $p_{\text{eff}}$ , usually measured as root mean square, rms), but also on other factors such as the maximum level of sound pressure, rise and decay time of the sound impulse, duration of the procedure, the number of sound impulses, and the number of sound impulses per minute (DEWI 2004). Mortalities, according to LARSEN (1985 in: TURNPENNY & NEDWELL 1994, and in: GAUSLAND 2003), can occur when the sound pressure impulse exceeds 229 dB re 1  $\mu$ Pa, and the rise and decay time is less than 1 ms. Whereas higher sound levels may be caused e.g. by airguns (chapter 5.2.1.3), these short rise and decay times are only reached by explosions.

In fish, sound can cause temporary threshold shifts (POPPER & CLARK 1976, SCHOLIK & YAN 2001), which are usually reversible. Physical damage can occur by the destruction of hair cells in the sensoric epithelium of the inner ear (HASTINGS et al. 1996, MCCAULY et al. 2003). Possible physiological effects to sound are typical primary and secondary stress responses with increased levels of e.g. cortisol and glucose (SANTULLI et al. 1999, SMITH et al. 2004).

Similar sound exposures cause different effects in different fish species. While a 24-hour white noise exposure (0.3 - 4.0 kHz, 142 dB re 1  $\mu$ Pa) led to a significant threshold shift in a hearing specialist (the fat headed minnow, *Pimephalus promelas*) (SCHOLIK & YAN 2001), the same treatment did not significantly decrease the hearing threshold of a hearing generalist (the bluegill sunfish, *Lepomis macrochirus*) (SCHOLIK & YAN 2002a).

### Behavioural effects: Avoidance

All impacts mentioned above were observed in fish exposed to a predefined sound level, mostly in special test equipment (pipes or cages), which they could not avoid. In the open sea however, animals have the possibility to escape noise by flight or avoidance. Impacts of sound are to be expected if the emitted sound overlaps in frequency and sound pressure level with the audiogram of the fish species in question.

Various studies have dealt with the impact that various sound stimuli have on certain fish species (i.a. ANRAKU et al. 1998, LEE et al. 1998). Deterring effects of high-frequency sound have been proved for alewives (*Alosa pseudoharengus*) (DUNNING et al. 1992, ROSS et al. 1993, 1996) and blueback herrings (*Alosa aestivalis*) (NESTLER et al. 1992). The twait shad (*Alosa fallax fallax*) also showed strong avoidance reactions to a high-frequency sound of 200 kHz (GREGORY & CLABBURN 2003). DUNNING et al. (1992) found stronger reactions to broad-band stimuli than to pure tones. For infrasound, a deterring effect on juvenile salmon-like fish (*Oncorhynchus tshawytscha*, *O. mykiss*) has

been proved (KNUDSEN et al. 1992, 1994, 1997). Startle responses in herring shoals were size-dependently caused by frequencies between 70 Hz und 200 Hz (BLAXTER et al. 19981, BLAXTER & HOSS 1981).

### **Behavioural effects: Attraction**

Several investigations have demonstrated an attracting effect of low-frequency sound on fish. RICHARD (1968) produced pulsated sounds in the range of 25 Hz to 50 Hz resembling the hydrodynamically produced sounds of hunting fishes. These sounds attracted various carnivorous bony fishes and some shark species, but not herbivorous reef fish. MYRBERG et al. (1972) found that with decreasing sound frequency, sharks were increasingly attracted by sound. CHAPMAN et al. (1974) observed that fish were attracted by the sound produced by the breathing of divers. Play-back tests with recorded respiration sounds led to significantly higher numbers of fishes in the vicinity of the loudspeaker. This was attributed to a conditioning effect which caused the fish to associate the sound with increased food supply by sediment plumes.

### **Masking**

It is known that many species communicate by sound. LUGLI et al. (2003) found that the communication frequencies of two freshwater gobies fall within a “quiet window” of the ambient noise. The mating male cod (*Gadus morhua*) produces low-frequency grunts in the frequency range of 50 Hz during the spawning period (BRAWN 1961). These grunts play an important role in the courtship display of the male. They attract the female, and remove competing males (BRAWN 1961). The importance of sound production among gadoid fish is further emphasised for haddock (*Melanogrammus aeglefinus*) by HAWKINS & AMORIM (2000), who state that the sound serves to bring the male and female fish together, and that sound plays a role in synchronising their reproductive behaviour. Studies by HAWKINS & RASMUSSEN (1978) proved that of nine northern European Gadidae species, four produced sounds. Besides the cod, these were the haddock (*Melanogrammus aeglefinus*), the lythe (*Pollachius pollachius*), and the tadpole fish (*Raniceps ranius*). It was observed that only larger individuals of cod (larger than 37 cm, BRAWN 1961), and in comparison between gadoid species only the larger species (HAWKINS & RASMUSSEN 1978) produce sounds.

In order to determine whether the operational noise of windmills reduces the distance over which fish communicate, WAHLBERG & WESTERBERG (2005) calculate the detection distance of haddock for intraspecific calls to be at a maximum 4 m. Within the distances at which the operational noise of wind turbines is louder than the ambient noise (up to 25 km) (WAHLBERG & WESTERBERG 2005), the detection range of the haddock calls is reduced. This could, in a worst case scenario, make spawning impossible. In their calculation, the authors do not allow for the temporal characteristics of the sounds. HAWKINS & RASMUSSEN (1978) cite unpublished work by A.D. Hawkins and Kathleen Horner which proves that the shorter a sound, the higher its amplitude must be to be detected by the cod. A short tone pulse at 160 Hz of 100 ms duration must be 10 dB higher in amplitude than a pulse of 1 s to be detected against a random background. The calls of all gadoid species are very short in their characteristics (haddock: knocks 7.5 - 100 ms, grunts 25 - 150 ms, cod: grunt 75 - 200 ms, lythe: grunt up to 100 ms, tadpole fish: grunt about 100 ms), which might serve the purpose of being difficult for other fish to detect at a great distance (HAWKINS & RASMUSSEN 1978). As a consequence of the short duration of the sound communication among gadoid fish, the effect of masking background noise produced by the construction of offshore wind farms might be even more severe.

It has to be stated that no sound evaluation is possible based on the current knowledge if such a masking would pose a significant problem for the reproductive behaviour of fish. Neither long term effects upon individuals nor upon populations are predictable. However, masking as well as the generation of signals similar to those produced by the fish themselves have the potential of interfering with communication by means of sound in fish. As sounds are used by fish during important activities as spawning, such noise may disrupt their lives significantly (ICES 2005).

## Habituation

Habituation to sound stimuli was observed by KNUDSEN et al. (1997) in salmon (*Oncorhynchus tshawytscha*) and rainbow trout (*O. mykiss*) for low-frequency sounds (10 Hz) and the initial flight response. However, the general avoidance response to the sound stimulus did not habituate even after twenty trials. A quick habituation to sounds > 20 Hz is quoted by WESTERBERG (1994) from repeatedly failed attempts by LARSSON (1992) to keep fish away from the intake of a power turbine by the use of sound. In contrast, salmon could be successfully deterred by 10 Hz tones, i.e. there was no habituation in the infrasonic range (ENGER et al. 1993). The possibility of the occurrence of a habituation effect might be indicated by the fact that fish perceive sound in a similar manner as humans do, i.e. they form an acoustic image of their surroundings from the background noise (FAY 1998 in: WAHLBERG & WESTERBERG 2005). Thus, fish may be able to associate sounds induced by a wind farm with structures that do not mean any danger to them (WAHLBERG & WESTERBERG 2005).

### 5.1.1 Construction Phase

During the construction of anthropogenic structures at sea, piling causes very strong impulsive noise. An impulse can be compared to the mean pressure of the impulsive sound, multiplied by its duration (NEDWELL et al. 2003). Typical piling procedures during the construction of offshore wind farms consist of 30 to 50 impulses per minute over periods of one to various hours. For the auditory effect on the organism, the intensity of a single impulse can be decisive. The degree of injury caused by impulse-like underwater noise is not only dependent on its sound pressure, but also on its duration (NEDWELL et al. 2003). Thus, the relevant data in connection with construction noise is not the average continuous level, but the maximum level  $L_{peak}$  and the single event sound pressure level  $L_E$  (corresponds to SEL, sound exposure level) (DEWI 2004, Figure 5).

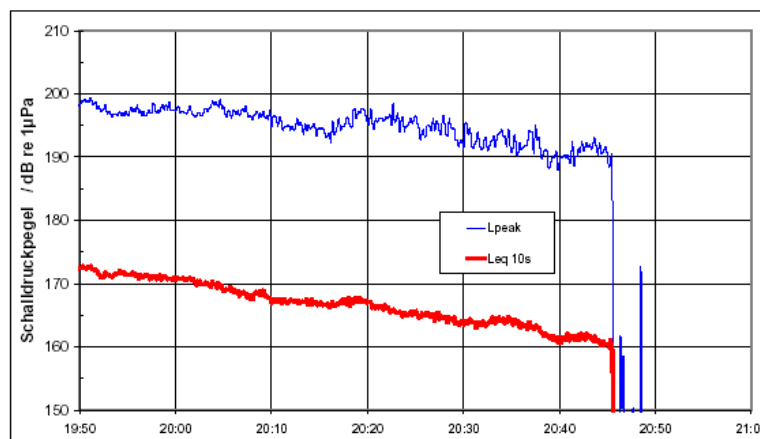

Figure 5: Piling at FINO I (D), pile 3: SPL in the course of the measurement (measurement of DEWI at anchor, distance to source about 350 m) (from: DEWI 2004).

### 5.1.1.1 Offshore Wind Farms

#### Sound emission

During the construction of offshore wind farms, noise is generated by the construction of the foundation (piling) as well as by construction and supply vessels.

The frequency range and the sound level of vessels depend on their size, their system of powering, and their operation. The frequencies emitted are between 20 Hz and 10 kHz with source levels (SL) of from 130 to more than 160 dB re 1  $\mu$ Pa at 1 m (RICHARDSON et al. 1995). This sound induction can last over extended periods. The construction work at the Horns Rev wind farm, DK, lasted from September 2001 to September 2002, with an interruption of several months during the winter. Some fifteen to twenty ships were present for construction and supply purposes (TECH-WISE/ELSAM 2003).

There is no common procedure for the foundation grounding of wind turbines at sea. Different types of foundations may be considered, depending on water depth, sediment and turbine type. The grounding of gravity foundations causes minor sound emissions. Monopiles are cylindrical large-bore steel tubes with thick walls which are hammered upright into the sea bed. Tripod and jacket foundations have various small (partly inclined) tubes which are hammered into the bottom. Piling can be done with impact or vibration hammers. At sea, impact hammers with a high maximum sound energy will probably be used (DEWI 2004). Sound emissions vary with seabed structure, water depth, type of foundation, type of piling, and mitigation measures adopted.

Results from measurements during piling have been published from Sweden (MCKENZIE MAXON 2000), Great Britain (NEDWELL et al. 2003), and Germany (DEWI 2004) (Table 1). The range of piling noise has its maximum in the low frequency range. Highest energies occurred in the range of 30 - 2.000 Hz (Table 1, Figure 6). This frequency range overlaps completely with the hearing range of many fish species.

Table 1: Sound emissions during construction of various offshore piles.

Author	MCKANZIE MAXON (2000)	NEDWELL et al. (2003)	NEDWELL et al. (2003)	DEWI (2004)	DEWI (2004)	DEWI (2004)
Location of Measurement	Utgrunden, Sweden	North Hoyle, GB	North Hoyle, GB	FINO I, Germany pile 3	FINO I, Germany pile 4	SKY 2000, D, research pile
Type of Foundation	monopile	monopile, 4 m diameter	monopile, 4.2 m diameter	jacket (four legs), 1.5 m diameter	jacket (four legs), 1.5 m diameter	monopile, 3 m diameter
Type of Piling	impact piling	impact piling + rock socket drilling	impact piling	impact piling	impact piling	
Number of turbines	7	30	30	-	-	
Capacity of turbines [MW]	1.5	2	2	-	-	
Seabed condition	sand	hard rocket & gravelly sand	sand	sand	sand	sand
Year of measurement	2000	2003	2003	2003	2003	2002
Water depth [m]	5 - 6	7 - 11	0.4 - 7.5			
Depth of measurement [m]	2 - 3	5 - 10	5 - 10	7 - 10		7
Distance of measurement [m]	30	250 - 6000	250 - 8000	350	400 m	40
Frequency of blows	max. 28/min	average 35/min		max. 60/min	0.9 - 0.7 Hz	
Duration of piling	1.5 h	5 months		2,5 h	2 h	
Number of blows	1320					
Frequencies with highest energies [hz]	100 - 2000	40 - 1000		125 - 1000	80 - 2.000	30 - 300
Maximum sound level of emissions [db re 1 $\mu$ pa]	$L_{peak} = 205$	$L_{p-p} = 198$		$L_{peak} = 199$	$L_{peak} = 193$	$L_{peak} = 204$
Calculated maximum source level in 1 m distance [db re 1 $\mu$ pa]	$L_{peak} = 227^*$	$L_{p-p} = 260$ (1 m depth)	$L_{p-p} = 297^{**}$	$L_{peak} = 238^*$	$L_{peak} = 232^*$	$L_{peak} = 228^*$

\*) calculated from original data, formula by THIELE (2002)

\*\*\*) SL is considered to be unrealistically high by the authors. This is due to the complex bathymetry of the site and very shallow water, leading to a very high transmission loss of about  $35 \log(R)$ .



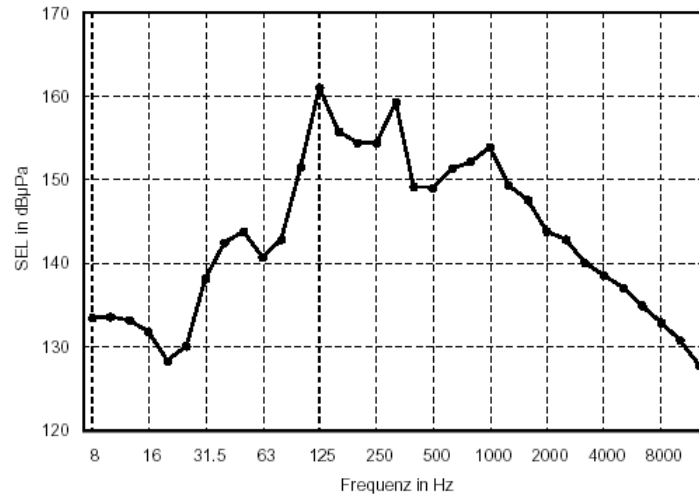

Figure 6: Third octave band of piling noise from piling at FINO I (D), pile 3 (from: DEWI 2004).

Measurements were undertaken at a certain distance from the source, in order to avoid the near field effect, and the source level (SL) at a distance of 1 m to the sound source is calculated. Often, SL is approx. 230 dB re 1  $\mu$ Pa (MCKENZIE MAXON 2000, DEWI 2004). High source levels of 260 dB re 1  $\mu$ Pa (peak-to-peak) were observed in North Hoyle, caused by the hard rock substrate. Top levels of SL = 297 dB re 1  $\mu$ Pa (peak-to-peak) were found in Scroby Sands, but these values are considered unrealistically high by the authors, and caused by the complex bathymetry of the site and the very shallow water (NEDWELL et al. 2003). By contrast, rock socket drilling was associated with relatively low noise level, and there is little likelihood of the noise from the drilling causing any environmental effect (NEDWELL et al. 2003).

DEWI (2004) observed decreasing sound levels during piling activity. With increasing bonding of the pile in the sea bed, sound levels dropped. This could be explained by the extension of the sound source, the pile, over the entire water column.

### Effect studies

Data on the effects of **research vessels** on fish were compiled by MITSON (1995). The focus was on cod (*Gadus morhua*) and herring (*Clupea harengus*), as these species seem to have the best hearing abilities among the commercially exploited species. The study concludes that positive avoidance reactions occur when the noise level of the ship exceeds the hearing threshold by 30 dB or more. Distances of reaction are given as 100 - 200 m for typical ship noise, and as 400 m for very loud vessels. In experimental studies, ENGAS et al. (1995) found avoidance reactions of cod and herring as a reaction to ship noise in the frequency range of 60 Hz to 3 kHz with a sound level of 118 dB re 1  $\mu$ Pa. By contrast, frequencies between 20 Hz and 60 Hz did not cause avoidance reactions. Another effect observed in a number of investigations was an impact on shoaling behaviour (VELLA et al. 2001). A threshold value of 120 - 130 dB (no further specification of level) for behavioural reactions of cod and herring is suggested by VELLA et al. (2001). SCHOLIK & YAN (2002b) caused a significant increase of hearing threshold (TTS) in the fat-headed minnow by experimental exposure to boat engine noise.

The knowledge of the effects of the sound of ships on fish, and especially that generated by ships using sonar systems, is summarised by ICES (2005). The authors note that it is difficult to draw definite conclusions. The data currently available on the

response of fish to sounds is not yet sufficient to develop scientifically supportable guidance on exposure to sound that will not harm fish. Therefore, precautions should be taken to minimise any damage. Effects on fish will be most severe when there is long lasting effect on the whole population and its ability to sustain itself. Deflection of migrating fish, displacement of fish from their feeding grounds, or disruption of spawning activities, especially when large numbers of fish are affected, may prove especially damaging. Precautionary mitigation measures would include not carrying out pile driving in confined areas in close proximity to migrating fish. If less noisy methods exist, these should be preferentially used (vibro-piling rather than percussive piling). Times of special sensitivity (migration peaks, spawning time) should be avoided. These measures apply to all sources of noise production.

**Wind farms:** Based on conclusions from the available basic literature on the hearing ability of fish and on studies of noise levels during piling, ENGELL-SØRENSEN & SKYT (2002) assume hearing damage for the fish resident in the Rødsand region, DK, to be unlikely. This assumption refers to the hearing generalists flounder (*Platichthys flesus*), plaice (*Pleuronectes platessa*), dab (*Limanda limada*), brill (*Scophthalmus rhombus*), sea scorpion (*Myoxocephalus scorpius*), eelpout (*Zoaraces viviparus*), sand eels and gobies (*Pomatoschistus* spp.). The authors believe that a certain degree of habituation of these species to the piling noise may occur. Resident hearing specialists are herring (*Clupea harengus*) and sprat (*Sprattus sprattus*). In their case, possible flight reactions are prognosticated. Moreover, damage to the auditory epithelia may occur, which is however temporary in most cases.

Studies of the impact of piling on fish were carried out in the harbour of Southampton during construction of the Red Funnel Terminal (NEDWELL et al. 2003). The authors noted no discernible increase of the signal when piling was taking place compared to when it was not. The vibropiling could not be discerned in the sound recordings. The background noise was dominated by other man-made noise, in particular by the movement of vessels, the passage of ferries into the terminal, and a dredger that was removing silt from the waterway by suction dredging. Background levels of up to 150 dB re 1  $\mu$ Pa occurred. The sound level of an impact driver employed at the same time was SL = 194 dB re 1  $\mu$ Pa. Cage tests on sea trout (*Salmo trutta*) revealed that neither kind of piling caused either startle responses (C-starts) in the animals nor increased levels of activity. No physical injuries were observed in the test animals within a radius of 400 m from the piling.

In the course of the San Francisco-Oakland Bay Bridge Demonstration Project in California, USA, sound levels between 160 und 196 dB rms [fast] re 1  $\mu$ Pa were measured during piling at a distance of 100 m to 200 m from the pile (PIDP 2001). Sonar observations during piling gave no sign of the disappearance of fish. In contrast, the animals seemed to drift passively by the tidal currents in areas of high sound intensity. Direct observations of seagulls preying on fish in general recorded few gulls in the area prior to pile-driving operations. After the beginning of pile-driving, the birds soon gathered in the project area. Fish were found dead primarily within a range of 50 m (n=13). The external and internal injuries which were observed gave reason to assume that, in addition to the direct deaths, there might be further mortalities, especially of species with swim bladders. The zone of direct mortality is about 10 - 12 m from piling, the zone of delayed mortality is assumed to extend out at least to 150 m (1.000 m) from piling. Cage tests on experimentally exposed fish revealed greater effects when using a larger hammer (1700 kJ, as compared with 500 kJ). The greatest effects were observed in a range of 30 m from piling. Preliminary results indicate increasing damage rates to the fish together with extended exposure times.

NEDWELL et al. (2003) calculate ranges for significant avoidance reactions of salmon (1400 m), cod (5500 m), and dab (1600) as a reaction to the piling noise of North Hoyle. The level of noise from the piling at North Hoyle is considered to be probably sufficient to cause local fish kill (NEDWELL et al. 2003).

Mitigation measures that reduce the possible effects to an acceptable level have to be taken in the following cases (NEDWELL et al. 2003):

1. Where species are displaced from a significant proportion of their feeding grounds;
2. Where there are endangered species, such that any affect is of unacceptable risk;
3. Where an affected species is an important foodstock for an endangered species, and the effect of the noise may be to make the foodstock less available to the endangered species;
4. Where the noise is in confined waters, a migratory route, or of sufficient duration that a significant proportion of the migratory period would be blocked;
5. Where the noise has an economic impact, for instance if whales were displaced from a whale watching area, or fish were displaced from fishing grounds.

### 5.1.1.2 Oil and Gas Exploitation

Seismic surveys at sea have the goal of finding geological structures that indicate hydrocarbon deposits. The functional principle of nearly every seismic source is the release of compressed air to produce an impulse-like signal and send it in the direction of the sea bottom. Today, pneumatically-driven impulsive underwater transducers, known as airguns, are usually used. The sound waves reflected by the underlying strata are received by hydrophones and then analyzed to determine the geological structure of the sea bed. Good echoes require repeated, momentary and high-energy pulses. Pulses are sent out by an array of airguns which are usually operated from observation vessels. A seismic survey can last between one day and several weeks, depending on the dimension of the investigation area. The sound levels emitted are typically on the order 226 dB re 1  $\mu$ Pa at 1 m for a single airgun, or 248 dB re 1  $\mu$ Pa at 1 m for an array (TURNPENNY & NEDWELL 1994). The fundamental frequencies fall within the range 0 to 120 Hz (TURNPENNY & NEDWELL 1994). The emitted frequencies correspond to the audiograms of many marine organisms and thus can affect their normal behaviour.

#### Effect studies

MCCAULY (1994) estimates the following zones of reaction for fish to sound emissions from seismic airguns (SL>200 dB):

- zone of physiological effects: 10 m - 200 m
- zone of avoidance: 10 m - 1 km
- zone of reaction: 10 m - 10 km
  - startle response:* 150 m - 300 m
  - alarm response:* 600 m - 1 km
  - minor reaction:* 2 km - 10 km
- zone of audibility: 10 m - 10 km

An earlier literature study on the impacts of seismic surveys on marine animals (TURNPENNY & NEDWELL 1994) concludes that serious injuries to fish (eggs to adults) only appear to occur at sound levels on the order of 220 dB re 1  $\mu$ Pa. Physical injuries occur in the form of tissue disruption, including swim bladder damage, damage to blood

cells, inner bleeding, or eye injury. Damage to the sensory epithelia of the inner ear is less severe. With increasing sound level, initially, damage to the inner ear will occur (from 180 dB re 1  $\mu$ Pa), followed by heart dysfunction (transient stunning; from 192 dB re 1  $\mu$ Pa) and internal injury (from 220 dB re 1  $\mu$ Pa). The experimental species were adult cod, plaice, anchovy and various whitefish (freshwater), and fish eggs and larvae of plaice, cod, red mullet, and anchovy (TURNPENNY & NEDWELL 1994). The reactions of eggs and larvae are more sensitive than those of adult fish. In addition to direct mortalities, eggs can show deformations of the chorion (outer egg membrane) or the vitelline membrane as well as spiral curling or displacement of the embryo. Larvae can react with reduced growth rates (TURNPENNY & NEDWELL 1994). However, the overall judgement of the authors is that the risk of injury to any life stage of fish due to normal seismic operational use is very low. Where injury has been demonstrated, it has been under experimental conditions which were either unrepresentative of normal operational use, or which would arise only under special circumstances (TURNPENNY & NEDWELL 1994).

Thresholds for avoidance reactions on airgun shootings typically range from 160 to 180 dB re 1  $\mu$ Pa (TURNPENNY & NEDWELL 1994). Flight reactions from the sound-intensive area have been described either by diving into deeper waters (demersal species) or by swimming horizontally away from the source (pelagic species). There is well-substantiated evidence to demonstrate that fish distribution and feeding behaviour can be affected by seismic operations.

A typical primary and secondary stress response, identified by variations in cortisol, lactat AMP, ADP, ATP and cAMP values, was reported by SANTULLI et al. (1999) from experimental seismic surveys on sea bass (*Dicentrarchus labrax*). The variations of biochemical parameters returned to within the physiological ranges within 72 h.

ENGAS et al. (1996) investigated the impacts of seismic surveys on fish. The study revealed that distribution, local abundance and catch rates of cod (*Gadus morhua*) and haddock (*Melanogrammus aeglefinus*) in the investigation area of 40 x 40 nmi were severely affected by seismic shooting. Trawl catches of both species and longline catches of haddock declined on average by about 50% (biomass), longline catches of cod were reduced by 21%. The most pronounced reduction occurred within the shooting area (3 x 6 airguns, 36 transects, each 10 nmi long, duration five days, maximum peak levels 249 dB re 1  $\mu$ Pa at 1m), where trawl catches of both species and longline catches of haddock were reduced by about 70%. However, reductions of catch rates were observed 18 nmi from the seismic shooting area. The effects on larger individuals (> 60 cm) were stronger than those on smaller fish. Abundance and catch rate did not return to pre-shooting levels during the five-day period after the shooting ended. The authors state the hypothesis that fish are scared by the sound generated by the air guns and leave the affected area.

Similar results were achieved by SKALSKI et al. (1992). They observed off California an average decline in catch per unit effort of rockfish (*Sebastes* spp.) hook-and-line fishery by about 50% at the use of a single airgun. PEARSON et al. (1992) determined threshold values for startle responses (200 - 205 dB re 1  $\mu$ Pa) as well as for alarm responses (180 dB re 1  $\mu$ Pa) in rockfish (*Sebastes* spp.) as a reaction to 10 min. exposures to sounds from a single airgun. LØKKEBORG & SOLDAL (1993 in: ENGAS et al. 1996) investigated catch data obtained from commercial vessels that happened to be operating on fishing grounds where seismic explorations were being conducted. The authors found a 55 - 80% reduction in longline catches of cod and a reduction of 80 - 85% in the by-catch of cod in shrimp-trawling. Especially in passive longline fishery, catch rates do not only depend on the local abundance, but also on the animals'

behaviour. Thus, reductions of catch rates may be a sign either of migration out of the area, or of a behavioural reaction that leads to a reduction of the bite reflex.

Some authors (KENCHINGTON 1999, GAUSLAND 2003) question the interpretation of the results by ENGAS et al. (1996). It seems to be generally accepted that the reduction of catch rates occurred as an effect of the seismic activities. However, the registration of continuously reduced catch rates over the whole further observation period of five days caused KENCHINGTON (1999) to propose the following interpretation: Probably the disturbance by seismic activity had caused the fish to continue their seasonal migration which had brought them to the survey area in the first place. Basically, this would be the continuation of a migration pattern that would have taken place in the near future anyway.

Different results were obtained by WARDLE & CARTER (1998). They undertook a field study in Loch Ewe, a coastal reef in Scottish waters. The authors investigated the behavioural response of wild fish using video cameras and tagging before, during and four days after airgun shootings (three airguns, peak levels of 218 dB re 1  $\mu$ Pa). The impacts of the airgun explosions were observed in the form of involuntary C-starts, after which the fish continued their previous activities. Continued flight reactions were observed only in cases when the airguns were sunk to the sea bed and the sound emission was accompanied by an optical stimulus in the form of a sand cloud. When the airguns were mid-water and outside the visible range, the fish exhibiting a C-start continued to swim towards the gun position, their intended swimming track apparently unaltered. The authors conclude that the seismic shooting did not cause direct behavioural effects in resident fish.

On the other hand, the observed absence of an alarm reaction might also be due to the experimental design with a maximum of one shooting per minute. This differs from the usual practice during seismic surveys (about one shooting every 5 to 15 seconds). The shot spacing may have been long enough for the fish to fully recover from the alarm response which initiated the C-turn. The sound source was stationary, by contrast to the usual method of using a moving ship. Therefore, it may not have constituted an approaching threat to the fish (MCCAULY et al. 2000).

Norwegian studies on the influence of seismic shooting (duration of 6 days in an area of 10 x 10 km, SPL 256 dB re 1  $\mu$ Pa) on the lesser sand eel (*Ammodytes marinus*) employed cage trials, ROV-operated video recordings, acoustic surveys as well as van Veen grabs of the buried animals (HASSEL et al. 2004). They could prove neither changes in population density nor direct cases of death. Behavioural reactions occurred in the form of C-like start reactions. The landings of Norwegian sandeel trawlers showed a temporary drop for a short period after the seismic experiment, which, however, might be attributed to other factors.

An Australian study (MCCAULY et al. 2000) registered a generic alarm response in various finfish at a distance of 2 to 5 km from the sound source (airgun). This went together with faster swimming at the bottom and/or a tightening shoal structure. The behavioural reactions observed also included startle response and habituation as well as a return to normal behavioural patterns 14 - 30 minutes after the airgun activity ended. General behavioural reactions occurred in periods of high airgun-exposure (156 dB re 1  $\mu$ Pa rms). Active avoidance reaction is expected at levels of 161 - 168 dB re 1  $\mu$ Pa rms. A compilation of threshold values for reactions to nearby airgun activities in various animal groups (whales, turtles, fish and squid) is given in MCCAULY et al. (2000) (Table 2). The authors register some agreement between the threshold values for the different animal groups.

Table 2: Summary of effects of nearby airgun operations on a range of marine fauna from the literature (from McCAULY et al. 2000, adapted). (\*: converted from mean peak to rms using -12 dB correction).

Source	Sound level [dB re 1 $\mu$ Pa rms]	Fish group	Effect
PEARSON et al. (1992)	149*	rockfish ( <i>Sebastes spp.</i> )	beginning behavioural reaction
PEARSON et al. (1992)	168*	rockfish ( <i>Sebastes spp.</i> )	pronounced alarm reaction
McCAULY et al. (2000)	182 - 195	<i>Pelates sexlineatus</i>	constant C-shaped startle response
PEARSON et al. (1992)	200 - 205*	selected rockfish species	C-shaped startle response provoked
WARDLE et al. (1998)	183 - 207*	various species	C-shaped startle response
McCAULY et al. (2000)	146 - 195	various species	no significant increase of physiological stress

A final assessment of the impacts of seismic surveys on fish is difficult. It seems certain that in the direct vicinity of a survey area and several kilometres beyond, the catch rates of commercial ground fish can decrease significantly (by 50% or more). On an individual level, behavioural effects were observed. The significance of those effects on the fish is difficult to estimate. The impacts of seismic surveys on spawning populations apparently have not yet been a distinct subject of investigation. However, it must be stated that there is no clear evidence of a damaging effect of seismic surveys on the spawning success, nor are there surveys that prove the opposite.

Because of comparable sound levels and frequency bands as well as the impulsive nature of both sound sources, the effects of seismic shooting on fish are to a certain degree comparable to those effects caused by piling noise for offshore wind farms.

### 5.1.2 Operational Phase

Constant sound emissions of anthropogenic structures are usually given as sound pressure level SPL (in decibel, dB). The formula  $SPL = 20 \log (P_{\text{eff}} / P_0)$  also includes the effective value  $P_{\text{eff}}$  (also rms-value = root mean square) and the reference value. The effective value is the sound pressure mean squared over a short period of time. In underwater acoustics the reference value usually is  $p_0 = 1 \mu\text{Pa}$  (DEWI 2004).

Moreover, in underwater acoustics the frequency spectra are usually specified as density spectra, which are standardised on a band width of 1 Hz. This results in the unit dB re 1  $\mu\text{Pa}^2/\text{Hz}$ . Referring to sound perception of mammals, the critical frequency band width in the range above 150 Hz is approximately  $1/3$  octave, thus, underwater sound is often displayed in  $1/3$  octave bands (DEWI 2004).

#### 5.1.2.1 Offshore Wind Farms

##### Sound emissions

Relevant emissions of offshore wind turbines are expected especially in the low-frequency range (WESTERBERG 1994, 2000b, DEGN 2000, HENRIKSEN 2002, BETKE et al. 2003, LINDELL 2003, DEWI 2004) (Table 3). Lowest frequencies were registered between

3 Hz (INGEMANSSONN 2003) and 63 Hz (DEGN 2000). The turbines also emit frequencies close to the infrasonic range and over about 1 kHz; however, those sound levels are usually below the level of background noise. Thus, the frequency range between 20 Hz and 1 kHz is of special importance for the assessment of sound emissions from wind turbines (DEWI 2004).

Sound pressure levels between 95 and 132 dB re 1  $\mu\text{Pa} / \text{Hz}^2$  were observed in spectral densities normalised to a bandwidth of 1 Hz (Table 3). Care has to be taken as these units cannot be directly compared to hearing thresholds of fish, which are usually computed as rms-units in  $1/3$  octave levels.

$L_{\text{eq}}$ -levels in  $1/3$  octave bands were registered between 102 and 125 dB re 1  $\mu\text{Pa}$  (Table 3). Measurements taken at Utgrunden wind farm (Kalmarsund, Sweden) registered two to three maxima between 39 Hz and 500 Hz in the  $1/3$  octave band, depending on the velocity of the rotor blades. The aggregated level in this range increased from 103 dB re 1  $\mu\text{Pa}$  at the lowest rotational speed to 117 dB re 1  $\mu\text{Pa}$  at rated output (DEWI 2004).

Based on the measurements from a single wind turbine, HENRIKSEN (2002) assumes that there will be no summation of the sound emissions from several turbines if the distance among them is in the range of about 800 m. This assumption is supported by calculations of DEWI (2004) for the sound emission of an entire wind farm with seventy turbines placed at intervals of 0.8 km. According to the model, no summation will occur.

Sound emissions of a turbine depend on a variety of factors. Fixed parameters are e.g. type and size of turbine, foundation, water depth, or sediment characteristic. In addition, variable parameters, especially wind speed, are of major importance. A comparison of the three available measurements from Utgrunden/Kalmarsund, as well as the data of WESTERBERG (1994, 2000b) and HENRIKSEN (2002) (Table 3), demonstrates the influence wind speed has on the level of sound emission. Higher wind speeds lead to higher sound levels because the rotation speed of the turbine increases (LINDELL 2003). Basic parts of the underwater sound are transmitted by the bending vibrations of the tower, whereas those parts transmitted through the air by rotor blades and the gondola can be neglected (DEGN 2000, BETKE et al. 2003, LINDELL 2003).

Extrapolations from 500 kW turbines to larger ones lead to the assumption that especially in the frequency range beneath 100 Hz sound emission will be higher (DEGN 2000). The forecast is that large turbines with a gravity foundation will be louder in the frequency range beneath 50 Hz, whereas monopiles will be noisier in the frequency range between 50 Hz and 500 Hz (DEGN 2000). However, it has not yet been proved that the prognosis is transferable to other locations. Modelling by DEWI (2004) referred to vibration measurements of an onshore turbine (E 112: rated output 4.5 MW, gondola mass 500 t, gearless). For the offshore turbine a monopile grounding and water depths of 30 m was assumed. Aggregate levels of 149 dB re 1  $\mu\text{Pa}$  were numerically determined with respective maxima in the individual frequencies of 139 and 140 dB re 1  $\mu\text{Pa}$ , respectively. At a distance of 20 m, the amplitudes were nearly half and reached values of 134 dB re 1  $\mu\text{Pa}$  at 130 Hz and 200 Hz (DEWI 2004).

The prevailing measurements do not allow reliable predictions concerning sound emissions of future wind farms. Most measurements were taken on single turbines, whereas the pilot phases of German wind farms are mostly planned with eighty wind turbines (DAHLKE 2002, SRU 2003). Furthermore, wind farms are planned with turbines in the size class of about 5 MW; to date however, published measurements only exist for turbines with a maximum capacity of 1.5 MW (WESTERBERG 1994, 2000b, BETKE et al. 2003, LINDELL 2003, DEWI 2004) or 2 MW (HENRIKSEN 2002).

Table 3: Sound emissions of various offshore wind turbines.

Author	WESTERBERG 1994	WESTERBERG 1994	DEGN 2000	DEGN 2000	DEGN 2000	DEGN 2000
Location of measurement	Svante, Sweden	Svante, Sweden	Vindeby, Denmark	Gotland, Sweden	Extra polation	Extra polation
Type and capacity of the wind turbine	Windworld As 220 kW	Windworld As 220 kW	Bonus 6E, 450 kW	Windworld No. 4, 550 kW	2 MW	2 MW
Type of foundation	Tripod	Tripod	Concrete gravity foundation	Steel monopile	Concrete gravity foundation	Monopile
Time of measurement	1991 - 1993		Feb. 2000	Jan. 2000	Extra polation	Extra polation
Water depth [m]	6	6	2.5	4		
Depth of measurement [m]	4	4	1,2	2		
Measuring gauge	SPL (averaging over 60 s)		<sup>1</sup> / <sub>3</sub> octave bands with linear averaging over 4-5 minutes, Values as power spectral density-units [dB re 1 $\mu$ Pa /Hz <sup>1/2</sup> ]			
Distance from measurement to source [m]	100	100	14	20	14	20
Wind velocity [m/S]	6	12	13	8	13	8
Frequency range in which turbine emissions exceed background level			10 Hz - 400 Hz	63 Hz - 630 Hz	10 Hz - 200 Hz	10 Hz - 500 Hz
Maximum sound level of emissions [dB re 1 $\mu$ Pa]	102 dB re 1 $\mu$ Pa at 16 Hz	113 dB re 1 $\mu$ Pa at 16 Hz	120 dB re 1 $\mu$ Pa /Hz <sup>1/2</sup> at 25 Hz	95 dB re 1 $\mu$ Pa /Hz <sup>1/2</sup> at 150 Hz	132 dB re 1 $\mu$ Pa /Hz <sup>1/2</sup> at 25 Hz	115 dB re 1 $\mu$ Pa /Hz <sup>1/2</sup> at 25 Hz



Table 3: (continued)

Author	DAMSGAARD (2002)	DAMSGAARD (2002)	DAMSGAARD (2002)	DAMSGAARD (2002)	DEWI 2004	LINDELL 2003
Location of measurement	Vindeby, Denmark	Gotland, Sweden	Middelgrunden, Denmark	Middelgrunden, Denmark	Utgrunden, Sweden	Utgrunden, Sweden
Type and capacity of the wind turbine	Bonus 450 kW	WindWorld 550 kW	Bonus 2 MW	Bonus 2 MW	GE 1.5s 1.5 MW	GE 1.5s 1.5 MW
Type of foundation	Concrete gravity foundation	Steel monopile	Concrete gravity foundation	Concrete gravity foundation	Monopile	Monopile
Time of measurement	n.a.	n.a.	n.a.	n.a.	Sept. 2003	Nov. 2002 bis Feb. 2003
Water depth [m]	n.a.	n.a.	n.a.	n.a.	Turbines 4-10	Turbines 4-10
Depth of measurement [m]	n.a.	n.a.	n.a.	n.a.	7	13 - 18
Measuring gauge	Measurement of sound level in a distance of 10 - 40 m from sound source. Calculation of source level in (1 m distance) (after 10 log r) Values as power spectral density-units [dB re 1 $\mu\text{Pa}^2/\text{Hz}$ ]				$L_{\text{eq}}$ (averaging over 64 s) 1/3 oktave bands	$L_{\text{eq}}$ (averaging over at least 3 minutes)
Distance from measurement to source [m]	1	1	1	1	110	83
Wind velocity [m/s]	13	8	6	13	17	14
Frequency range in which turbine emissions exceeds background level					30 Hz - 1 kHz	30 Hz - 800 Hz
Maximum sound level of emissions [db re 1 $\mu\text{Pa}$ ]	130 dB re 1 $\mu\text{Pa}/\text{Hz}^{1/2}$ at 25 Hz	108 dB re 1 $\mu\text{Pa}/\text{Hz}^{1/2}$ at 16 und 160 Hz	111 dB re 1 $\mu\text{Pa}/\text{Hz}^{1/2}$ at 25 Hz	115 dB re 1 $\mu\text{Pa}/\text{Hz}^{1/2}$ at 125 Hz	113 dB re 1 $\mu\text{Pa}$ at 50 and 200 Hz	125 dB re 1 $\mu\text{Pa}$ at 180 Hz

\*) : During the measurement period, the turbines only operated at 10% of rated output, thus the measured levels are probably not representative of all operating conditions.

## Effect studies

VELLA et al. (2001) compared the audiograms of fish (salmon *Salmo salar*, dab *Limanda limanda* and cod *Gadus morhua*) with the sound emissions of an existing wind turbine (Svante, Sweden). The hearing capacity overlapped with the emitted sound only for cod, whereas the hearing thresholds of salmon and dab were above the operational sound level of the turbine. Thus, impacts were forecast only for cod. However, the investigations were based on measurements of a 220 kW wind turbine (Windworld AS, 35 m high, tripod grounding). The offshore wind farms in the North and Baltic Seas are planned with much larger turbines of the 5 MW class, therefore higher sound levels are to be expected.

Before the construction work for the Horns Rev wind farm started, HOFFMANN et al. (2000; *Baggrundsrapport 24*) assumed that the effect of sound emission of the turbines on fish would be negligible. Effects were considered possible in the low-frequency range of less than 50 Hz. These frequencies basically occur in the immediate surrounding of a few hundred meters around the turbines. An impact on fish was not expected due to the small size of the low-frequency acoustic field. Furthermore, the authors assumed an ability of habituation. In the frequency range between 50 Hz and 2 kHz, little reaction was expected. In comparison with the overall sound level of other anthropogenic utilisations, the effect of wind turbines was considered small. Sound emissions of more than 2 kHz were only considered to be of minor significance.

To date, the only fish-biological survey to deal with the impact of wind farm induced sound on fish was conducted by WESTERBERG (1994, 2000b) at the Svante wind farm in Sweden. By means of ultrasonic telemetry and fishing it was shown that European eels (*Anguilla anguilla*) passing a single (220 kW) wind turbine at a distance of 0.5 km did not substantially change their swimming behaviour. When the rotor was stopped, the CPUE (catch per unit effort) of cod (*Gadus morhua*) and roach (*Rutilus rutilus*) was significantly higher in the vicinity of the turbine (100 m) than at distances between 200 and 800 m. These findings indicate an attraction for fish, possibly due to the reef effect. By contrast, during operation, the catch rate decreased by a factor of two within 100 m from the windmill under otherwise similar conditions. This could be interpreted as a displacement effect. However, no investigations of the variation in fish density were performed prior to construction, so the differences may be attributable to other factors.

Recently, WAHLBERG & WESTERBERG (2005) reviewed the hearing ability of fish in relation to offshore wind farms. By combining the results of direct measurements of turbine emissions and sound attenuation with the audiograms of fish, the authors reached the following conclusions: Depending on species, fish will perceive the operational noise of wind turbines at distances of approx. 0.4 km to 25 km. Within this zone, intraspecific communication may be restrained by masking. The operational noise will not physiologically damage the hearing ability. It is assumed that fish will permanently be displaced only within a range of 4 m from the wind turbine and only at high wind velocities ( $> 13 \text{ ms}^{-1}$ ). The authors state, however, that these conclusions have to be viewed with great caution, as the existing data are prone to major uncertainties.

### 5.1.2.2 Oil and Gas Exploitation

Noise is generated during all phases of oil and gas production. Noise sources may be continuous or impulsive and can be described as being either transient or permanent (SIMMONDS et al. 2004). Activities generating noise are many and varied, ranging from seismic surveys (exploration), through pile driving, pipe-laying (installation), drilling and platform operations (production), to explosive wellhead decommissioning (decommissioning). Most noise sources associated with oil and gas production can be broadly classified as noise generating from (1) machinery, (2) propellers (cavitation), (3) hydrodynamic excitation of structures (turbulent flow), or (4) impulsive sound sources (airguns or pile drivers) (Table 4).

Table 4: Summary of noise sources and activities associated with oil and gas exploration and production (from SIMMONDS et al. 2004)

Phase	Activity	Source	Source type	Duration
Exploration	Seismic surveys	airguns and seismic vessels	impulsive & continuous	transient (weeks)
	Exploratory drilling	Machinery noise	continuous	transient (weeks)
	Transport (equipment & personnel)	Helicopters & supply vessels	continuous	transient (days, weeks)
Construction	Pile driving	Pile drivers & supply vessels	impulsive & continuous	transient (weeks)
	Pipe-laying	Pipe laying vessels & support	continuous	transient (weeks)
	Trenching	Trenching vessels & support	continuous	transient (weeks)
	Transport (equipment & personnel)	Helicopters & vessels	continuous	transient (weeks)
Production	Drilling	Machinery noise	continuous	permanent (years)
	Power generation	Gas turbines, generators	continuous	permanent (years)
	Pumping	Pumps, separators	continuous	permanent (years)
	Transport (equipment & personnel)	Helicopter & support vessels	continuous	temporary (days, weeks)

No special investigations concerning the impact of the operational phase of oil and gas production on fish are known.

### 5.1.2.3 Sand and Gravel Extraction

Gravel dredging at sea is usually done by means of hopper excavators (self-navigating suction excavators). The spoil, a mixture of sand and water, is sucked by the free navigating vessel through a suction tube on the sea-bottom and drawn into the hopper. Sometimes the gravel or gravel sand passes through an on-board dressing turbine before being transported to an unloading unit. During suction, the high-performance pumps and the vessels' propulsion emit broad-band sound with a source level of 185 dB re 1  $\mu$ Pa into the water (RICHARDSON et al. 1995 in KOSCHINSKY 2004). Highest sound levels are emitted in the range of around 20 Hz to 1 kHz. This fraction of the frequency spectrum can still be perceived at a distance of 25 km, and some frequency components (discrete tones) can even be perceived at a greater distance. Thus, the sound emitted by a hopper excavator can be compared to that of a super tanker (RICHARDSON et al. 1995). However, a tanker usually leaves an area in relatively short time, whereas the excavators employed in gravel dredging stay more or less at the same place for an extended period.

There are no special studies on the impacts of acoustic disturbances by sand and gravel dredging on fish; therefore, assessments can only be made on the basis of conclusions by analogy from studies that have been performed in a different context.

## 5.2 Sediment Disturbance

The erection of offshore foundations (for offshore wind farms and oil and gas platforms) and the commercial sand and gravel dredging lead to disturbances of the marine sediments, which induces potential impacts on the fish fauna. In this connection, we will here address the impacts on fish fauna of

- sediment re-suspension and turbidity plumes (chapter 5.2.1), and
- changes in sediment composition (chapter 5.2.2).

### 5.2.1 Sediment Re-suspension and Turbidity Plumes

Sensitivity of fish to suspended sediment is on the one hand species-specific, and on the other, highly dependent on the animals' stage of life (egg, larva, juvenile or adult). Apart from biological parameters, the degree of disturbance also depends on a number of abiotic factors. These include (HYGUM 1993):

- density and distribution of sediment particles;
- their mineral composition;
- their adsorption and absorption capacity;
- the prevailing oxygen and temperature conditions.

Another decisive factor is the impact duration of the suspended matter on the animals (CLARKE & WILBER 2000). Basically, the degree of interference increases with particle concentration and duration of interference (NEWCOMBE & MACDONALD 1991 in: CLARKE & WILBER 2000), as well as grain size and angularity. Moreover, every abiotic parameter which accelerates the animals' metabolism leads to increased sensitivity to sediment suspensions (ENGELL-SØRENSEN & SKYT 2001), because along with increased

metabolism, the respiration rate also increases. Therefore, the gills are highly exposed to the sediment load of the water (O'CONNOR et al. 1976 in: CLARKE & WILBER 2000).

Eggs and larvae are significantly more affected by increased sediment loads than juvenile or adult fish (ENGELL-SØRENSEN & SKYT 2001, CLARKE & WILBER 2000). Sediment concentrations in the range of milligrams per litre can be lethal for eggs and larvae, while for juveniles and adults this effect is not to be expected below concentrations of grams per litre (ENGELL-SØRENSEN & SKYT 2001).

The mortality rates of adult fish, eggs and larvae have been compared in dependence on the sediment concentration by CLARKE & WILBER (2000) for estuarine and anadromous species (Figure 7).

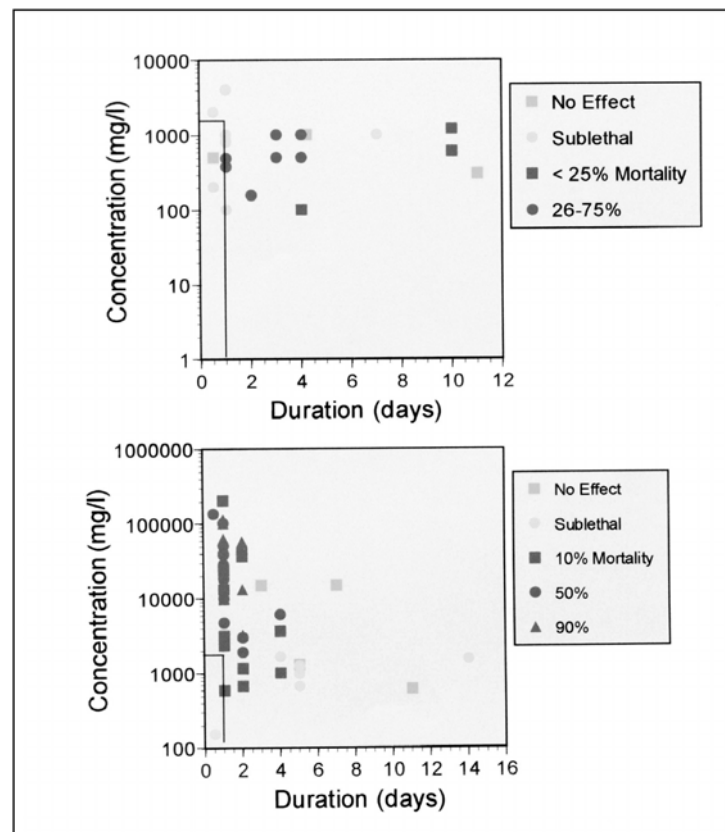

Figure 7: Responses of estuarine and anadromous fish egg and larvae (top) and adults (bottom) to suspended-sediment concentrations at the given dosages. The area within the rectangles depicts a probable dosage range associated with most dredging operations (from CLARKE & WILBER 2000).

The survival and development of pelagic eggs (in open water) basically depends on their ability to remain in the upper water layers where the abiotic parameters (e.g. oxygen content and salinity) are more favourable than in deeper waters. If suspended material adheres to fish eggs or deposits on it, they become heavier and sink to the bottom (BIRKLUND & WIJSMAN 2005). Both cases imply the potential danger of oxygen deficiency. Furthermore, increased mortalities caused by benthic predation or by mechanical and physical stress are to be assumed (WESTERBERG et al. 1996).

A basin test by WESTERBERG et al. (1996) investigated the impact of different sediment concentrations on the buoyancy of pelagic cod eggs (*Gadus morhua*). A nearly proportional correlation between increased sinking rates and the amount of suspended sediment (lime/clay) as well as to the duration of interference was derived. The tests

revealed a sinking rate of 0.02 psu/h  $\approx$  mg/l. This serves as a calculation basis for the cumulative loss of buoyancy (measured in psu) if the sediment concentration and the duration of interference are known (WESTERBERG et al. 1996). Thus, the authors state that the exposition to sediment concentrations of 5 mg/l for 11 hours will increase the sinking rate of cod eggs to the same degree as a reduction of salinity by 1 psu (APPELBERG et al. 2005).

Increased mortalities of cod eggs were not found below long-time particle concentrations of > 100 mg/l (WESTERBERG et al. 1996, APPELBERG et al. 2005). At shorter durations of exposition (three days), significantly higher mortalities could not be registered below particle concentrations of 200 mg/l (WESTERBERG et al. 1996). The authors assume that the proven negative effect can be generalised to all pelagic spawning species.

Reduced breeding success of various estuarine and freshwater species was found by AULD & SCHUBEL (1978 in: ENGELL-SØRENSEN & SKYT 2001) at sediment concentrations of 500-1000 mg/l. CLARKE & WILBER (2000) mention significantly lower values of 100 mg/l for the eggs of the coastal estuarine species striped bass (*Morone saxatilis*) and white perch (*Morone americana*).

Adverse effects for herring eggs were proven neither by MESSIEH et al. (1981) nor by KJØRBE et al. (1981). Even when covered by a thin sediment layer (7000 mg/l), according to MESSIEH et al. (1981), no substantial mortality rates were observed. KJØRBE et al. (1981 in: BIRKLUND & WIJSMAN 2005, CLARKE & WILBER 2000) state that herring eggs (*Clupea harengus*) showed no increased mortality, either at sediment (silt) concentrations of 5-300 mg/l (10 days), or at a shorter but higher-dosed (500 mg/l) exposure.

Demersal fish eggs are also affected by suspended matter. NEWCOMBE & MACDONALD (1991 in: ENGELL-SØRENSEN & SKYT 2001) cite mortalities of 100% for the eggs of the rainbow trout (*Oncorhynchus mykiss*) at sediment concentrations of 1000-2500 mg/l and six days' exposure. For dog salmon (*Oncorhynchus keta*) the authors specify egg mortalities of 77 - 90% after long-term exposure (163 days). However, the particle concentration in this test was only 97 - 11 mg/l.

Fish larvae tend to be more sensitive to suspended sediments than fish eggs of the same species (ENGELL-SØRENSEN & SKYT 2001). This has been proven in tests with cod larvae and cod eggs which were simultaneously exposed to the same test conditions. Larval mortality was about three times higher than egg mortality (WESTERBERG et al. 1996). At concentrations of 10 mg/l, WESTERBERG et al. (1996) already observed significantly increased mortality rates of cod larvae.

Many species (e.g. herring, plaice, Dover sole, brill, cod) feed optically during their larval stage. However, they mostly do not perceive their prey until it comes very close (millimeters) (BONE et al. 1995 in: ENGELL-SØRENSEN & SKYT 2001). Decreased visibility in the water body due to increased sediment concentrations makes foraging much more difficult for the larvae. Mostly affected are species that feed on plankton (phyto- and zooplankton). In contrast to mobile food, planktonic organisms do not move out of the turbidity plume; rather, they are moved along with it by the water current (HANSSON 1995). When the interruption of feeding is too long, larvae come to a point where they become too weak to eat and die ("point of no return").

The effect of fine sediment particles (silt) is especially negative for the larvae, because they adhere to the gills and cause suffocation (de GROOT 1980 in: ENGELL-SØRENSEN & SKYT 2001).

Reduced ingestion rates of herring larvae were found by JOHNSTON & WILDISH (1982 in: ENGELL-SØRENSEN & SKYT 2001) at suspension rates of 20 mg/l. Furthermore, they found a correlation between the impact intensity and the age of the larvae. The smaller the larvae the stronger was the impact. Herring larvae which were exposed to increased sediment concentrations (540 mg/l) showed significantly reduced growth rates (MESSIEH et al. 1981). Lethal consequences were found by HANSSON (1995) for particle concentrations of > 100 mg/l. Mortality rates of 100% are documented by MESSIEH et al. (1981) for a concentration of 19 g/l and an exposure time of 48 hours.

For coastal estuarine larvae of American shad (*Alosa sapidissima*), yellow perch (*Perca flavescens*), white perch (*Morone americana*) and striped bass (*Morone saxatilis*), AULD & SCHUBEL (1978) state increased mortalities at sediment exposures of 500 mg/l for 4 - 3 days. Pacific herring (*Clupea harengus pallasii*), living in estuarine habitats during the larval stage, reduced their ingestion at particle concentrations of 2000 mg/l (BOEHLERT & MORGAN 1985 in: CLARKE & WILBER 2000).

Juvenile and adult fish of all species react with avoidance behaviour to sediment concentrations in the range of milligram per litre (ENGELL-SØRENSEN & SKYT 2001). Higher concentrations (g/l) may lead to lethal consequences.

Significant avoidance behaviour of juvenile herring (*Clupea harengus*) was shown by MESSIEH et al. (1981) at particle concentrations as low as 12 mg/l. For adults, the authors assume a similar reaction. JOHNSTON & WILDISH (1981) observed flight reactions of adult herring at concentrations of 10 mg/l. In laboratory tests WESTERBERG et al. (1996) investigated the behaviour of herring (*Clupea harengus*) and cod (*Gadus morhua*) to sediment exposure in a more differentiated manner. In both species, they found tolerance thresholds of about 3 mg/l, which were significantly below the above cited sources.

For salmonidae (salmon and trout), evasive movements are proved at significantly higher sediment concentrations (> 100 mg/l) and exposure times (1 hour) (NEWCOMBE & MACDONALD 1991). Lethal effects are documented by the authors at concentrations from 1 - 49 g/l and exposure times of four days. Flight reactions of smelt (*Osmerus eperlanus*) occurred even at 22 mg/l (WILDISH & POWER 1985 in: ENGELL-SØRENSEN & SKYT 2001).

Plaice (*Pleuronectes platessa*) survived suspensions of 3000 mg/l for a period of fourteen days (NEWTON 1973 in: MOORE 1991). Thus it becomes clear that demersal species (flatfish) can tolerate much higher sediment concentrations than pelagic species.

Additional to the reactions demonstrated, the following effects are also possible:

- clogging of gills,
- skin injuries,
- poor visibility (forage).

If sediment particles deposit in or on the gills, the gas exchange with the water is constrained, leading to decreased oxygen transfer (ESSINK 1999, CLARKE & WILBER 2000). This effect is strongest for juvenile fish, since they have smaller gills, so that the openings between the gill arches are more easily clogged or stuck together. Moreover, the metabolism rates of small fish are significantly higher than those of larger fish (oxygen demand/body weight), making them less tolerant to reduced oxygen transfer (MOORE 1991). Clupeidae in particular are vulnerable to gill clogging because of their long, densely-spaced gill-rakers (ENGELL-SØRENSEN & SKYT 2001).

If animals are hit by coarse sediment particles, this can lead to superficial injuries of the skin, which makes them susceptible for parasites or other pathogens (EVERHART & DUCHROW 1970 in: JOHNSTON 1981).

Not only fish larvae, but also the juveniles and adults of many species use their optical sense to find food. Thus, reduced ingestion rates must also be assumed for them when increased sediment loads in the water either cover the benthic prey or makes it invisible, due to the strong turbidity (DANKERS 2002, POSFORD DUVIVIER ENVIRONMENT & HILL 2001, CLARKE & WILBER 2000).

The sediment type is of major importance for the amount of light penetration in the water. DANKERS (2002) points out that fine sand does not absorb much light, whereas clay or a coagulate of clay and organic material can absorb much light.

Light is the most important limiting factor for primary production by phytoplankton. Therefore, decreased light intensities can have negative consequences for primary production and thus for many organisms higher in the food web (DANKERS 2002). Furthermore, a decrease in light penetration can give rise to shorter or shifted bloom periods of algae or shifts in species composition of phytoplankton communities (JANKOWSKI & ZIELKE 1996, GROENEWOLD & DANKERS 2002 in: DANKERS 2002). Besides decreased transparency, shifts of the spectral range and polarisation pattern are of major importance (ESSINK 1999).

Furthermore, increased suspensions can also affect zooplankton (alimentation basis). Since the suspended material is mostly anorganic, an increase changes the organic/anorganic ratio. Zooplanktic feeders also have to absorb more sediment in order to ingest enough food (DOUBEN in: DANKERS 2002).

An increase in the sediment concentration also involves increased nutrient contents, which is judged as a positive effect for primary production, and hence for the alimentation basis, by JANKOWSKI & ZIELKE (1996).

All fish species mentioned in the Appendix II of the Habitat Directive are migrating species. POSFORD DUVIVIER ENVIRONMENT & HILL (2001) point out that their migration might be affected due to significantly increased sediment suspensions along the migration routes.

### **5.2.1.1 Offshore Wind Farms**

The sediment loads and construction periods for four different foundation types were compared for the Danish Nysted offshore wind farm (Rødsand) by ENGELL-SØRENSEN & SKYT (2001). Precise conclusions were drawn regarding the impacts of the foundation on fish in their various life stages (egg - larvae - juvenile - adult) by means of a detailed simulation (DHI 2000) of the expected sediment suspension of a gravity foundation (type 1 in Table 5) A work schedule of twelve hours a day was simulated as well as a shift of twenty-four hours.

Both alternatives show sediment concentrations of more than 10 - 15 mg/l only in the direct vicinity of the digging area. These concentrations will only be exceeded in 10% of the construction period.



Table 5: Specification of Sediment Removal and Construction Time of various Foundation Types (from SEAS 2000 in ENGELL-SØRENSEN & SKYT (2001) (adopted).

72 wind turbines	Foundation type 1: Gravity low	Foundation type 2: Gravity high	Foundation type 3: Monopile drilled/sluced	Foundation type 4: Monopile pile-driving
Material removal (m <sup>3</sup> ) total	106,000	40,000	28,000	16,000
Dug-up material (m <sup>3</sup> ) total	102,000	38,000	21,000	15,000
Sediment plume(m <sup>3</sup> ) total	4000	2000	7000	1000
Construction time/ foundation:				
Preparation	7 days	5 days	2 days	2 days
Installation	6 hours	6 hours	12 hours	4 hours
Scour protection	4 days	4 days	2 days	2 days

In comparing these data gained from a computer simulation with the cited literature statements (chapter 5.2.1), the disturbance to be expected is as follows:

- Species spawning pelagically during the construction phase will be temporarily affected by negative effects on their eggs in the surrounding of the foundations (from 5 mg/l on).
- Also demersal eggs will be potentially affected only in the direct vicinity of the foundations. Compared to pelagic eggs, however, they can tolerate higher suspension rates, thus smaller negative effects are to be expected.
- The potential for disturbance of fish larvae is similar to that of fish eggs.
- The simulated sediment concentrations do not imply lethal impacts on juvenile or adult fish. However, referring to the literature, flight or avoidance behaviour in the immediate vicinity of the foundations might occur.

Interferences with the benthic fauna in the course of the removal or digging-up of sediment is another indirect source of disturbance (ENGELL-SØRENSEN & SKYT 2001). For some fish species (especially flatfish) this means a reduction of their food supply. However, the authors do not expect impacts on the fish population unless the food situation had already been precarious before the construction.

According to the calculation the foundations "Type 2" and "Type 4" require significantly less sediment removal during construction (Table 5), ENGELL-SØRENSEN & SKYT (2001) assume that the degree of potential interferences in the case of these constructions is lower than that for construction type 1.

In the case of construction "Type 3", a significantly higher sediment disturbance has been calculated, on the other hand the construction period is much shorter (Table 5). Therefore, an assessment of the extent of disturbance by means of a conclusion by analogy from the simulated values of foundation "Type 1" is not possible (ENGELL-SØRENSEN & SKYT 2001). This is also true for tripod or jacket foundations which are planned for most of the offshore wind farms applied for in Germany.

### 5.2.1.2 Sand and Gravel Extraction

During the extraction of marine substrates (sand and gravel), the extracted sediment mixed with water is pumped into the dredger or the transportation barge. The excess water flows back into the sea, carrying suspended fine sediments which form a turbidity plume. Sometimes the non-required sediment parts are dumped from the ship directly back into the sea (screening), which increases the formation of turbidity plumes (BIRKLUND & WIJSMAN 2005; ICES 2001, GUBBAY 2003, POSFORD DUVIVIER ENVIRONMENT & HILL 2001). The mechanical disturbance and the suspension of the sediment on the sea bottom caused by the suction head contribute to the formation of turbidity plumes to a smaller extent (ICES WGEXT 1998 in: HERRMANN & KRAUSE 1998 POSFORD DUVIVIER ENVIRONMENT & HILL 2001, ICES 2001, GUBBAY 2003).

Depending on the technology employed and the type of sediment, amounts of 2-10% (HYGUM 1993), 0.1-26% (BIRKLUND & WIJSMAN 2005), 0.5-25% (NIELSEN 1997 in: HERRMANN & KRAUSE 1998) resp. 1.26-2.62% (WATER CONSULT 1997 in: HERRMANN & KRAUSE 1998) of the extracted material are flushed back into the sea, together with the excess water. In case of a sediment screening, the percentage of flushed material can be up to 190% of the total extracted sediment (BIRKLUND & WIJSMAN 2005).

During the alluvial deposition and sedimentation of the extracted material, suspended particles can be released. If the extracted material is used in the open water, a cast away of 30-40% has to be calculated for lime or mud (NIELSEN 1997 in: HERRMANN & KRAUSE 1998). During sand and gravel deposition, however, only small amounts of fine sediments are suspended, since most of them have already been suspended at the extraction site (NIELSEN 1997 in: HERRMANN & KRAUSE 1998).

Decisive factors for the formation of turbidity plumes are the natural turbidity of the water in the extraction area as well as the percentage of mud. Strong turbidity plumes are formed in areas of low energy intrusion. Least turbidity increase is to be expected in coastal areas where naturally increased erosion is common. According to the literature, turbidity increases of 8- to 400-fold occur in the course of extraction processes (HYGUM 1993, ICES 1992).

The temporal and spatial expansion of turbidity plumes essentially depends on the locally prevailing hydrographical parameters (temperature, salinity, flow velocity and sea state). Moreover, differences in expansion are depth-dependent (GUBBAY 2003). A comprehensive review of the formation, development and behaviour of turbidity plumes in the water body is given by DANKERS (2002).

Usually, sediment concentrations rapidly decrease with increasing distance from the source. This fact is reflected i.a. in studies by KJØRBOE & MOHLENBERG (1981, in: HYGUM 1993), who observed sediment concentrations of 3-5000 mg/l directly adjacent to a dredger. However, concentrations of more than 100 mg/l were restricted to a range of about 150 m. At a distance of 650 m the concentration was a mere 10 mg/l and at a 1000 m distance no turbidity increase could be observed.

The investigations by HITCHCOCK & DRUCKER (1996 in: BIRKLUND & WIJSMAN 2005, POSFORD DUVIVIER ENVIRONMENT & HILL 2001, ICES 2001) revealed that within a range of 200 - 500 m from the dredger, 80% of the suspended sediment (fraction >0.063 mm) had already sunk to the ground. However, the smaller sediment fractions (<0.063 mm), can be dispersed over great distances. In another extraction project HITCHCOCK et al. (2002) found considerable sedimentation rates in an area of 300 m. Comparable values were revealed in model calculations of the sediment decomposition at Kriegers Flak (WATER CONSULT 1997 in: HERRMANN & KRAUSE 1998).

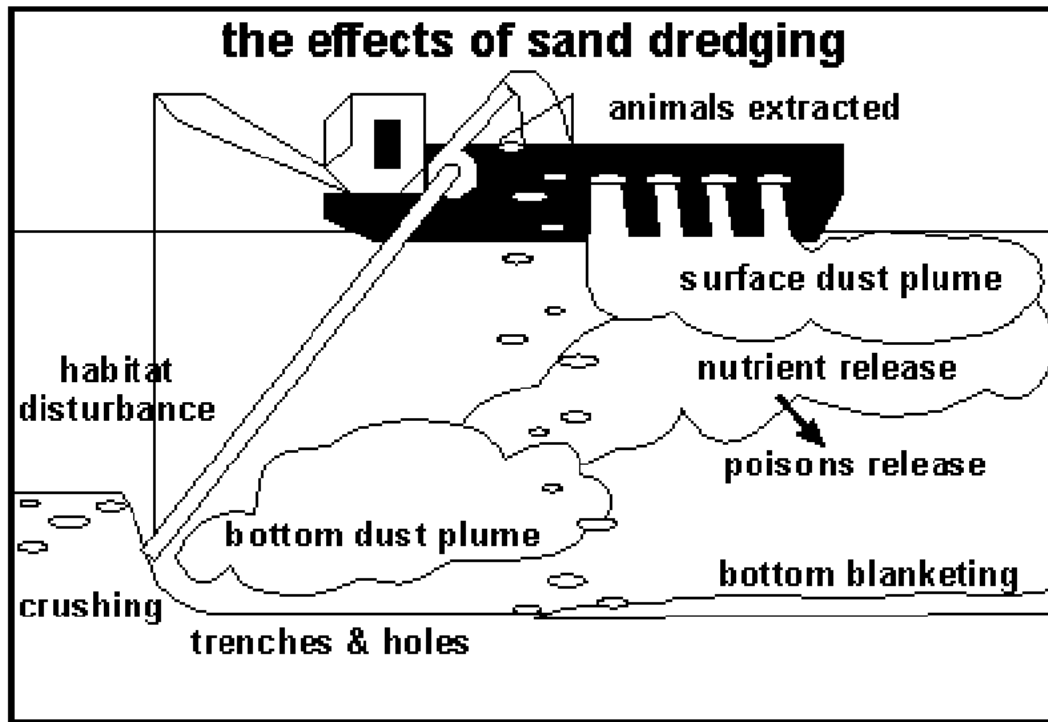

Figure 8: Schematic drawing of the formation of sediment resuspensions/turbidity plumes during sand extraction (from PHUA et al. 2004).

KENNY & REES (1996) as well as HITCHCOCK & DRUCKER (1996) could prove that suspended sediments remain more movable by tides and waves over a long period. Thus, even after the turbidity plumes have vanished, increased dredging-related risk remains for benthic organisms of being covered by sand (food supply), and for demersal fish eggs remains. The effects of turbidity plumes are summarised by PHUA et al. (2004; Figure 8).

A comparison of literature values for sediment concentrations in the surroundings of sand and gravel dredging with values regarding the sensitivity of fish species at their various life stages (Chapter 5.2.1) leads to the following scenario of disturbance:

In the direct surrounding of the dredging, the suspended material can reach lethal concentrations for fish eggs and larvae. Juvenile and adult fish will probably react to these small-scale high sediment concentrations by flight or avoidance. At 3-5 g/l, however, the expected concentrations might also have lethal consequences for juveniles or adults.

In the area bordering the direct surrounding (up to < 150 m of the extraction area), sediment concentrations of  $\geq 100$  mg/l are reached, which could cause higher mortality rates for the eggs or larvae of many fish species.

In the further surroundings (approx. 150 - 600 m) at concentrations of 10 mg/l, negative effects are to be expected only for very sensitive species. The literature indicates that the effects on these species will be restricted to the egg or larval stages.

Regarding the generality of the above statements, the concluding remarks in Chapter 5.2.2.2 have to be considered.

A number of technical processes are suitable to mitigate sediment-caused losses. These include optimised pump systems and a decreased working pace, as well as special equipment (e.g. silt curtains) to block fine sediment. Sedimentation tanks can serve to avoid sediment release at the deposition site (HERRMANN & KRAUSE 1998).

### 5.2.1.3 Oil and Gas Exploitation

For sediment re-suspension during the installation of offshore pipelines, calculations for the gas pipeline BalticPipe are available (DONG NATURGAS A/S, 2001a). In the context of project-planning, the EIA addressed three different landfall locations (water depth up to 6 m) in Denmark and two in Poland. For the Danish sites, the sediment intrusion due to construction work was simulated by a mathematical model. The data serve as an assessment basis for environmental compatibility (DONG NATURGAS A/S, 2001b; Table 6).

The forecast of potential impacts on fish and other faunistic elements is basically restricted to a comparison between the results of the simulation and the experience gained during the construction of the Øresund Bridge (Table 6). On the basis of this project, sediment concentrations of 6 mg/l are stated as the tolerance thresholds for sensitive pelagic fish (e.g. herring), and concentrations > 10 mg/l as the tolerance thresholds for benthic fish (cod, various flatfishes and eel) (DONG NATURGAS A/S, 2001a). The results of the simulation indicated that, depending on the landfall location, sediment concentrations of > 10 mg/l were reached or exceeded for 10% - 50% of the construction period. On the other hand, it turned out that the area where sediment concentrations of > 10 mg/l occurred, according to the calculations, for more than 50% of the construction period (thirty-three days), was restricted to 0 – 1.25 km<sup>2</sup>. For 25% of the construction period (sixteen days) this area comprises 0 to 15 km<sup>2</sup>.

The potential impacts of sediment disturbance were not expected to mean a significant impact on the adult fish population in the course of the environmental impact assessment for the BalticPipe pipeline (DONG NATURGAS A/S, 2001a). For this assessment, the authors refer to the surveys regarding the construction of the Øresund Bridge.

Fish species using the area near the landfall location as spawning or breeding habitats could be affected by the increased sediment loads in the water or by the increased sedimentation rates for a short time during the construction phase (DONG NATURGAS A/S, 2001a).

Effects on demersal fish eggs and larvae of plaice, turbot and flounder are possible in the direct vicinity of the construction site. No detectable effects on older individuals of these species are expected because of the temporal and spatial limitation of the impacts (DONG NATURGAS A/S, 2001a).

Table 6: Concentrations of suspended sediment, sedimentation and sedimentation rates together with registered effects on transparency/visibility and fauna (from DONG NATURGAS A/S 2001b).

Concentration	Effect
Concentration of suspended matter in Øresund: Winter: 0-2 mg/l (periods with wind: 5-15 mg/l) Summer: 2-4 mg/l (because of phytoplankton)	Normal
Suspended sediment: 2 mg/l	Visible
Suspended sediment: 28 mg/l	Reduction of transparency/visibility into the water column down to 1 meter (bathing water quality criteria "Blue flag")
Suspended sediment: 6-10 mg/l	Escape reaction of fish
Suspended sediment: 15 mg/l	Effect on foraging of birds
Sedimentation: 60 g/m <sup>2</sup> /day	Reduced settling of mussel spat ( <i>Mytilus edulis</i> ) on the seabed
Sedimentation: 240 mm Sedimentation rate: 70 mm/ month	<i>Macoma Balthica</i> (no impact on survival)
Sedimentation: 100 mm Sedimentation rate: 23 mm/ month	<i>Corophium volutator</i> (50% mortality)
Sedimentation: 300 mm Sedimentation rate: 23 mm/ month	<i>Myra arenaria</i> (50% mortality)

No general information concerning the impacts of pipeline laying on fish fauna can be derived from these results.

### 5.2.2 Sediment Composition

The sediment composition can be affected by substrate removal, or by the sedimentation of suspended material. Here, sensitivity is species-specific as well.

Variations in the sediment composition are highly important for those species that depend on certain bottom substrates for feeding, spawning, or breeding. For example herring preferably spawn each year anew on the same flow-influenced, stone and gravel substrate (ICES 1992, BIRKLUND & WIJSMAN 2005, POSFORD DUVIVIER ENVIRONMENT & HILL 2001, KJØRBOE et al. 1981). Sandeels also depend on the composition of the bottom substrate, because they spend long periods (at night and during winter) buried in the upper layers of the sea floor (JENSEN et al. 2003). On the basis of various studies (JENSEN 2001, WRIGHT et al. 2000, MACER 1966, PINTO et al. 1984, RELAY 1970, SCOTT 1973, all cited in: JENSEN 2003) it could be proved that sandeels prefer mainly sandy substrates with medium to very coarse grain sizes (0.25-1.2 mm). However, substrates of mud and silt, medium to coarse sand as well as stones, are avoided. Also sediments with a fine grain fraction (silt, clay, fine sand) of more than 6% (JENSEN et al. 2003) and 10%, respectively (WRIGHT et al. 2000 in: BIRKLUND & WIJSMAN 2005), are avoided. The demands on the spawning grounds correspond with the described habitat (JENSEN et al. 2003).

A review of the preferred spawning substrates of various species is shown in Table 7 (OSPAR 1999).

Table 7: Preferred Spawning Substrates of Various Fish Species (from OSPAR 1999).

Species name	English common name	Depth (m)		Bottom spawning description
		Minimum depth range	Maximum depth range	
<i>Alosa fallax</i>	Twaite shad	0	100	Bottom spawning? in tidal reaches of rivers
<i>Ammodytes marinus</i>	Raitt's sandeel	30	150	Presumed to lay eggs on sand and fine gravel
<i>Ammodytes tobianus</i>	Sandeel	0	30	Lays eggs in sand which adhere to the sediment
<i>Aphia minuta</i>	Transparent goby	0	60	Lays eggs in empty bivalve shells
<i>Apletodon microcephalus</i>	Small-headed clingfish	0	25	Demersal eggs on kelp holdfasts
<i>Blennius pavo</i>	No known common name	0	30	Lays eggs in crevices and hollowed debris
<i>Blennius rouxi</i>	Striped blenny	0	30	Eggs laid under stones guarded by males
<i>Buenia jeffreysii</i>	Jeffrey's goby	10	330	Eggs found in mollusc shells—guarded by male
<i>Chromis chromis</i>	Damselfish	0	40	Territorial, eggs laid on bed and guarded by male
<i>Clupea harengus</i>	Herring	0	150	Oviparous - demersal eggs
<i>Crystallogobius linearis</i>	Crystal goby	5	400	Lays eggs on seabed in worm tubes at around 30 m
<i>Diplegogaster bimaculata</i>	Two-spotted clingfish	0	55	Demersal eggs on stony grounds
<i>Eleginus navaga</i>	Navaga	0	20	Spawns in 8–10 m over rocky or sandy bottoms—eggs sink
<i>Gobius couchi</i>	Couch's goby	5	5	Presumed eggs laid in rocky crevices
<i>Gobius cruentatus</i>	Red-mouth goby	0	5	Presumed eggs laid on undersides of stones
<i>Gobius gasteveni</i>	Steven's goby	36	74	Presumed eggs laid under stones on seabed
<i>Gobius niger</i>	Black goby	2	70	Eggs laid on underside of shell debris or stones, etc.
<i>Gymnammodytes semisquamatus</i>	Smooth sandeel	20	200	Laying eggs over sand gravel (or coarse sand)
<i>Hyperoplus lanceolatus</i>	Greater sandeel	0	150	Laying eggs in sand—larvae pelagic
<i>Lebetus guilleti</i>	Guillet's goby	2	30	Presumed to lay eggs on shells or stones
<i>Lebetus scorpioides</i>	Diminutive goby	30	375	Presumed eggs laid on shells or stones
<i>Lepadogaster candollei</i>	Connemarra clingfish	0	5	Demersal eggs laid on the underside of stones
<i>Lepadogaster lepadogaster</i>	Shore clingfish	0	25	Demersal eggs on underside of boulders
<i>Lesuerigobius friesii</i>	Fries' goby	20	350	Presumed to lay eggs on seabed debris—muddy ground?
<i>Mallotus villosus</i>	Capelin	0	100	Demersal eggs on gravel in shallow coastal waters
<i>Muraena helena</i>	Moray (eel)	0	200	Not known
<i>Myoxocephalus scorpius</i>	Bull-rout/Father lasher	4	60	Eggs laid on seabed and guarded by males
<i>Myxine glutinosa</i>	Hagfish	0	150	Not known
<i>Pomatoschistus lozanoi</i>	Lozano's goby	0	30	Eggs deposited on empty bivalve shells—guarded by male
<i>Pomatoschistus microps</i>	Common goby	0	5	Lays eggs in hollow of inverted bivalve shells
<i>Pomatoschistus minutus</i>	Sand goby	0	20	Lays eggs in empty bivalve shells guarded by the male
<i>Pomatoschistus norvegicus</i>	Norway goby	30	280	Presumed to lay eggs in shells or under stones
<i>Pomatoschistus pictus</i>	Painted goby	0	50	Lays eggs on bivalve shells guarded by male
<i>Pungitius pungitius</i>	Ten-spined stickleback	0	5	Eggs laid in nest made by male and guarded
<i>Raja alba</i>	White skate	40	370	Oviparous, demersal eggs
<i>Raja batis</i>	Common skate	30	600	Oviparous, demersal eggs
<i>Raja brachyura</i>	Blonde ray	0	100	Oviparous, demersal eggs
<i>Raja clavata</i>	Roker	5	280	Oviparous, demersal eggs
<i>Raja fullonica</i>	Shagreen ray	35	500	Oviparous, demersal eggs
<i>Raja microocellata</i>	Small-eyed ray	0	100	Oviparous, demersal eggs
<i>Raja montagui</i>	Spotted ray	25	120	Oviparous, demersal eggs
<i>Raja naevus</i>	Cuckoo ray	20	150	Oviparous, demersal eggs
<i>Raja undulata</i>	Undulate ray	0	200	Oviparous, demersal eggs
<i>Scylliorhinus canicula</i>	Lesser-spotted dogfish	3	400	Lays eggs in shallow water
<i>Scylliorhinus stellaris</i>	Nursehound/Bull huss	1	70	Lays eggs in shallow water
<i>Serranus hepatus</i>	Brown Comber	0	100	Specific site chosen to lay eggs then guarded by male
<i>Spondyliosoma cantharus</i>	Black sea-bream	0	20	Eggs laid in nests/hollows on seabed—guarded by male
<i>Thorogobius ephippiatus</i>	Leopard-spotted goby	6	40	Presumed eggs laid in crevices

If the sediment composition is changed due to the increased intrusion of sediments of different grain sizes or mineral characteristics, this can negatively affect reproduction success (ICES 1992, ICES 2001, PHUA et al. 2004, POSFORD DUVIVIER ENVIRONMENT & HILL 2001, BIRKLUND & WIJSMAN 2005). This is especially true for such species as herring whose complex demands on the spawning habitat are mostly met locally on smaller areas (KJØRBOE et al. 1981, POSFORD DUVIVIER ENVIRONMENT & HILL 2001). Various studies have shown that changes in sediment that serve as spawning grounds either prevent fish from spawning at all or cause them to lay their eggs in less adequate areas (de GROOT, 1979, in: PHUA et al. 2004).

A removal of sediment primarily has consequences for the infauna and epifauna, as they are also removed or destroyed. For many fish species, benthic organisms are an important alimantation base (DAAN et al. 1990, COHEN et al. 1980, SISENWINNE et al. 1984, JONES 1984: all in: ICES 2001). A temporary destruction of the zoobenthos and/or a permanent change of the community can lead to restricted food supply for many fish species (PHUA et al. 2004; GUBBAY 2003). ROZENMEIJER (1999, in: PHUA et al. 2004) documented a detectable effect on the plaice population and its reproduction success by large-scale sand removal in benthos-rich areas.

However, injured animals can represent increased food supply in the area of mechanical sediment interference for a short time (POSFORD, DUVIVIER, ENVIRONMENT and HILL, 2001 in: PHUA et al. 2004), which can lead to temporarily increased fish densities in the interference area (PHUA et al. 2004).

#### **5.2.2.1 Offshore Wind Farms**

For the Horns Rev wind farm in the Danish North Sea, JENSEN et al. (2003, 2004) investigated possible changes in the sediment regime due to the wind farm construction, which might have a negative effect on the local sandeel population. The parameters investigated were the density of the sand eel population and the sediment composition before (2002) and after (2004) the construction of the wind farm. The results did not prove any change in the sediment composition in the wind farm area. Especially for the finest grain sizes, no increase was found. Furthermore, no decrease in sandeel densities (all species summarised) was found. By contrast, from 2002 to 2004 the density of sandeels (all species summarised) increased in the wind farm area.

#### **5.2.2.2 Sand and Gravel Extraction**

In traditional marine sand and gravel dredging, two different extraction techniques with different impacts on the marine environment are employed. While static dredging creates holes with depths of 10 - 20 m and diameters of 10 - 75 m (PHUA et al. 2004, ICES 2003, BIRKLUND & WIJSMAN 2005, NEWELL et al. 1998 in: POSFORD DUVIVIER ENVIRONMENT & HILL 2001), the trailing suction dredger digs shallow holes (20 - 30 cm deep, 2 - 2.5 m wide), sucking up the sediment from the sea bottom (PHUA et al. 2004, POSFORD DUVIVIER ENVIRONMENT & HILL 2001). Compared to static dredging, the extraction area is much wider. However, the physical change of the extraction area, which in static dredging is a long-term effect (sometimes permanent), has to be considered. An overview of the various extraction techniques is shown in Table 8 and Table 9.

Table 8: Effects of different extraction techniques (from PHUA et al. 2004).

Dredge depth	Simplified nit visualisation	Example/ Case	Effects	Potential effects
Shallow dredging (+/-2m)		Terschelling, The Netherlands (RIACON Project) - 14-20m deep water - vol. extracted 2.1 mil.m <sup>3</sup> - 1.5 m thick layer of sand - highly dynamic system (VAN DALFSEN & ESSINK, 1997)	After 1 year, extraction favoured bivalve recruitment; - <i>Spisula</i> sp., - <i>Tellina fabula</i> , - <i>Tellina tenuis</i> . These species however, failed to establish lasting populations. After 2 years, long lived macro fauna species abundance recovered (minor changes in sediment structure). Conditions after dredging mainly favoured opportunistic species (polychaetes). Local population of <i>Donax vittatus</i> , was seriously affected by sand extraction-disappearance of adult specimens.	- Reduction in benthic species is a reduction of food supply for demersal fish. - There were no serious effects for the common scoter, as the duck is able to dive up to 30m to collect molluscs. Dredging extensively within the 20m depth contour could have serious repercussions for this species.
Deep dredging (+/-20m)		The Netherlands-off Hock of Holland. (PUTMOR project) - Extraction pit of 10 m deep (1300 m long, 500 m wide) - 22 m water depth pit left open from 1/10/99-1/4/00. after that filled with harbour mud The Netherlands, (beach nourishment near Heemskerk/Wijk aan Zee) PUNAISE project - pit depth 7m, then refilled with sand - highly dynamic environment	O <sub>2</sub> concentration within the sandpit was slightly lower than concentrations outside the sandpit. After 15 months, benthic fauna had largely recovered but there were still differences between the former borrow pit & surrounding area in terms of - community structure; - density; and - biomass. After 4 years, the borrow pit could not be distinguished from the surrounding area. The benthic community recovered completely .	The pit was refilled with harbour mud which encouraged the recovery process. As deep pits may have an entirely different sediment layer the pit bottom, this could encourage an entirely different composition of species to populate the pit area. Hence, the species composition will not resemble the pre-dredging state. The benthic community structure is severely disrupted and recovery to resemble similar age composition and community structure could take more than 2 years.

Table 9: Comparison of the impact of static dredging and trailer dredging on substratum and benthos (from POSFORD DUVIVIER ENVIRONMENT &amp; HILL 2001).

Parameter	Type of dredging	
	Static dredging	Trailer dredging
Depth of deposit worked	Relatively deep	Relatively shallow
Area of seabed worked	Relatively small	Relatively large
Effect on benthic habitats and communities	Local impact high but relatively small area affected	Local impact high and relatively larger area affected
Effect on seabed morphology	Formation of depressions in seabed	Formation of extraction "trails" over relatively extensive area

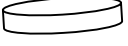
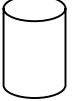

As stated above, this has direct as well as indirect impacts caused by reduced food supply for the benthos-feeding fish species (GUBBAY 2003). HITCHCOCK et al. (2002) found a decrease of species diversity by 66%, of population density by 87%, and of biomass of benthic invertebrates by 80 - 90%. Comparable data are presented by NEWELL et al. (1998 in: POSFORD DUVIVIER ENVIRONMENT & HILL 2001) for various sediment types (Table 10).

Table 10: The impacts of dredging on the benthic community composition of various habitats (from NEWELL et al. (1998 in: POSFORD DUVIVIER ENVIRONMENT & HILL 2001).

Locality	Habitat type	% Reduction after dredging		
		Species diversity	Individuals	Biomass
Chesapeake Bay	Coastal embayment mud-sands	70	71	65
Moreton Bay, Queensland	Sand	51	46	-
Klaver Bank, North Sea	Sand-gravels	30	72	80
Lowesoft, UK	Gravels	62	94	90

The regeneration of benthic fauna after a commercial sediment removal highly depends on the intensity and duration of the change and the sediment character. A number of studies make statements on expected regeneration periods. KRAUSE et al. (1996) and ICES (1992, 2001) specify regeneration periods from 1 month to 15 years and more (NEWELL et al., 1998; KENNY & REES, 1996; de GROOT, 1979). Recolonisation of mobile species takes place within a period of several weeks, during which time 70 - 80% of the original species diversity will have recovered (HITCHCOCK et al. 2002). The restoration of biomass ratios existing prior to dredging took 3 - 6 months (NEWELL et al., 1998; KENNY & REES, 1994 all in: POSFORD DUVIVIER ENVIRONMENT & HILL 2001). For immigrant species, too, spatial distance is a decisive factor. If the sediment character remains basically unchanged, the estimated regeneration periods are between a few months and five years (HYGUM 1993).

However, assessments of regeneration periods always depends on prevailing environmental conditions, and can only be generalised to a limited extent (GUBBAY 2003). A general overview of the factors responsible for the recolonisation of benthic fauna after dredging projects is given by POSFORD DUVIVIER ENVIRONMENT & HILL (2001):

- Species diversity in the area prior to dredging;
- Physical conditions in the operation area;
- Distribution of species in the surrounding area;
- Life cycle and growth rate of the local species: and
- Spatial expansion and intensity of sediment extraction.

Long-term changes are to be expected if the physical environment changes and thus a new flora and fauna is introduced (GUBBAY 2003).

In the north-eastern Atlantic (excl. Baltic Sea), thirty-eight species occur in the depth range above 100 m that depend on commercially used substrates, since they use these substrates as a preferred spawning, breeding or feeding habitats (OSPAR 1999) (Table 11). From the habitat qualities that economically used substrates provide for the fish species listed in Table 11, it can be assumed that these species are increasingly disturbed by sediment extraction.

Table 11: Species that use commercially utilised substrates as their spawning, breeding or feeding habitat (from OSPAR 1999).

Species name	English common name	Depth (m)		Seabed habitat description
		Minimum depth range	Maximum depth range	
<i>Alosa fallax</i>	Twaite shad	0	100	Pelagic but bottom spawning in gravel
<i>Ammodytes tobianus</i>	Sandeel	0	30	Found close to and burrowing in clean sandy seabed
<i>Arnoglossus imperialis</i>	Imperial scaldfish	60	100	Mainly on sandy or muddy grounds
<i>Arnoglossus laterna</i>	Scaldfish	10	60	Mostly on sandy bottoms
<i>Arnoglossus thori</i>	Thor's scaldfish	15	92	Mainly on mud and sandy bottoms
<i>Atherina presbyter</i>	Sand-smelt	0	20	Demersal, abundant on mud and sandy bottoms
<i>Blennius pavo</i>	(Not known)	0	30	Rocky shores, coasts, in sands and muds
<i>Buglossidium luteum</i>	Solenette	5	40	Mostly on sandy bottoms
<i>Callionymus reticulatus</i>	Reticulated dragonet	0	40	Living on clean sandy bottoms
<i>Dasyatis pastinaca</i>	Stingray	3	75	Bottom living on soft sand, less so on muddy ground
<i>Echiichthys vipera</i>	Lesser weever	0	50	Lies buried in sand foraging seabed for food
<i>Gobius cruentatus</i>	Red-mouth goby	0	5	Found on stones and sandy ground among eelgrass
<i>Gobius gasteveni</i>	Steven's goby	36	74	Found on muddy sand and with shell and small stones
<i>Gobius niger</i>	Black goby	2	70	Found on sandy and muddy bottoms and eelgrass
<i>Limanda limanda</i>	Dab	20	40	Mostly on sandy grounds migrating inshore to spawn
<i>Mallotus villosus</i>	Capelin	0	100	Shallow gravel areas form the spawning grounds
<i>Microchirus variegatus</i>	Thickback sole	37	92	Found on sand, and sand gravel bottoms
<i>Mullus surmuletus</i>	Red mullet	3	90	Sand and mud and also rocky bottoms, digs for prey
<i>Mustelus asterias</i>	Starry smooth hound	0	70	Mainly bottom living on sand and gravel grounds
<i>Myliobatis aquila</i>	Eagle ray	0	100	Part bottom living on sand or mud but also surface
<i>Platichthys flesus</i>	Flounder	0	55	Mostly on sandy and muddy bottoms
<i>Pomatoschistus lozanoi</i>	Lozano's goby	0	30	Mostly on coarse sand and muddy bottoms
<i>Pomatoschistus microps</i>	Common goby	0	5	Mostly on muddy sandy bottoms and in rock pools
<i>Pomatoschistus minutus</i>	Sand goby	0	20	Mostly on sandy grounds
<i>Pomatoschistus pictus</i>	Painted goby	0	50	Mostly on gravel, shell and coarse sand with stones
<i>Raja brachyura</i>	Blonde ray	0	100	Bottom living mostly on sandy sediments
<i>Raja microcellata</i>	Small-eyed ray	0	100	Bottom living mostly on sandy grounds
<i>Raja radiata</i>	Starry ray	50	100	Bottom living on sand, mud and occasionally gravel
<i>Raniceps raninus</i>	Tadpole-fish	0	100	Bottom feeding on sand and mud and algae on rock
<i>Scophthalmus maximus</i>	Turbot	0	80	On shell gravel, gravel and sand
<i>Scophthalmus rhombus</i>	Brill	9	73	Mostly on sand but also gravel and mud

A large number of studies and surveys have documented the environmental impact of sand and gravel dredging. An overview of the survey results in the course of various mining projects is given i.a. by ICES (2001) and BOYD et al. (2003). This information however, allows only generalised and limited statements of project-specific impacts on the fish fauna. This is also true for the information cited in this report. The ecological effects of sand and gravel dredging are too dependent on the local environmental conditions to make generally valid statements (PHUA et al. 2004).

### 5.2.2.3 Oil and Gas Exploitation

A significant effect of oil platforms and bridge foundations on the sand bottom biocoenosis in their surroundings has been shown in investigations of anthropogenic structures on sandy substrates off the coast of southern California (DAVIS et al. 1982 in: SVANE & PETERSEN 1997). One effect was the elimination of *Stylatula elongata* along with a parallel increase of *Diopatra* spp. Another effect was the significant change of the grain size distribution in the surroundings of the oil platform.

## 5.3 Introduction of Hard Substrates

Artificial hard substrate is generated by the building of anthropogenic structures in the sea; it changes the natural habitat structure. The impact is greater for regions with prevailing soft sediments. For example, natural stone fields or other hard substrate is scarce in large parts of the North Sea (EHRICH 2003).

The introduction of anthropogenic hard substrate into the marine environment is a common procedure when building so called artificial reefs. Various types of substrate serve the purpose of increasing catch rates for local fishery. The effect of increasing fish abundances is known for many species from natural reefs (PETERSSON 2000, STØTTRUP & STOKHOLM 1997). Accordingly, most studies regarding the significance of artificial reef structures for fish focus on fishery-related economic issues. Some general conclusions can nonetheless be drawn from these studies.

A primary effect of artificial hard substrate on fish is the existence of additional spawning habitat for substrate spawners. In the North Sea, these include the hooknose (*Agonus cataphractus*), the garpike (*Belone belone*), the herring (*Clupea harengus*), the lumpsucker (*Cyclopterus lumpus*), the striped sea snail and the Montague's sea snail (*Liparis liparis* and *L. montagui*), the butterfish (*Pholis gunellus*), the lesser spotted dogfish (*Scyliorhinus caniculus*), and the thornback ray (*Raja clavata*). The garfish, the lumpsucker and the butterfish spawn exclusively in shallow waters. For the herring, there are no known spawning grounds in the North Sea (EHRICH 2003). In addition to these substrate spawners; NORSKER (1997) names the Atlantic wolf-fish (*Anarhichas lupus*), the cod (*Gadus morhua*) and the black pollack (*Pollachius virens*) as typical species on Danish stone reefs. In the neighbouring sand bottom areas, frequent species include the plaice (*Pleuronectes platessa*), the flounder (*Platichthys flesus*), the turbot (*Scophthalmus maximus*), the brill (*Scophthalmus rhombus*), the lemon sole (*Microstomus kitt*) and the eelpout (*Zoarces viviparus*) (NORSKER 1997). Furthermore, PICKEN & MCINTYRE (1989) found haddock (*Melanogrammus aeglefinus*), ling (*Molva molva*), pollack (*Pollachius pollachius*), Norway pout (*Trisopterus esmarkii*), long rough dab (*Hippoglossoides platessoides*) and redfish (*Sebastes viviparus*) in the vicinity of offshore installations in the North Sea.

Hard substrate is characterised by fast fouling rates for invertebrates and macrophytes (only in the light-exposed eulitoral) (NEWELL et al. 1998, FAGER 1971 in: BOHNSACK & SUTHERLAND 1985), which has secondary effects. GARCIA (1991) described the colonisation of the research platform *Nordsee* after a fifty-four-week exposure with the following invertebrate species: *Obelia dichotoma*, *Tubularia larynx*, *Jassa falcata*, *Verucca stroemi*, *Balanus* sp., *Electra pilosa*, *Mytilus edulis*, *Hiatella arctica*, *Anomia* sp., *Pomatocerus triqueter*, *Ciona intestinalis* and *Metridium senile*. Similar fouling was found on a measuring tower in the area of the Horns Rev offshore wind farm within five

months after construction (LEONHARD 2000). The fouling also produces new spawning grounds for plant spawners; thus the overall number of species occurring is increased (GREGG 1991, NELSON 1985 both in: NORSKER 1997). SPANIER et al. (1990 in: SVANE & PETERSEN 1997) proved that especially juvenile fish are attracted by the algae. AMBROSE & SWARBRICK (1989) compared various artificial reefs in southern California and found that the macroalgae *Macrocystis* (widespread on reef structures in this region) has a strong effect on the fish community. The brown algae are a key factor in the formation and density of the reef's fish fauna. HUECKEL & BUCKLEY (1987) mention that algae fouling on artificial reefs increase food availability for many fish species. In a number of studies there are hints that the increased food supply on the reef structures is accepted by fish only to a limited extent (MOTTET 1981; in: BOHNSACK & SUTHERLAND 1985). RANDALL (1963 in: BOHNSACK & SUTHERLAND 1985) was able to prove by means of intestinal studies that reef-dwelling fish basically did not feed on the fouling. In the surrounding of oil platforms in the Gulf of Mexico, most fish were trophically independent of the fouling at the foundation (GALLAWAY & LEWBEL 1982 in BOHNSACK & SUTHERLAND 1985). TODD et al. (1992 in: JØRGENSEN et al. 2002) have attributed the presence of cod (*Gadus morhua*) close to a reef structure to the abundance of sand eels (*Ammodytes spp.*) in the surroundings of the reef.

The increase of fish biomass in the surroundings of artificial reefs is basically due to feeding in the surrounding habitats (BOHNSACK & SUTHERLAND 1985). Thus, it is of great importance for the fish that artificial reefs be situated near adequate feeding habitats (MOTTET 1981 in: BOHNSACK & SUTHERLAND 1985).

Not only the fish, but also the prey organisms increase in diversity and possibly also in biomass, because they also benefit from the increase of habitat complexity. As an example, higher abundances of sizeable adult cod and pollack were observed near wrecks and stone fields in the North Sea (EHRICH 2003). Higher densities of plaice and other flatfishes have been found near artificial reefs as well (POLOVINA & SAKI 1989), seemingly because they are attracted by the increased food supply.

The colonisation of artificial reefs often begins immediately (within hours or days) after the installation of the structures (NORSKER 1997). In addition to invertebrates, fish, too, have been observed in the vicinity of the newly established reef structures, often within a very short time period (STONE 1978, GROVE & YUNGE 1983, BOHNSACK & SUTHERLAND 1985). For this observation, AMBROSE & SWARBRICK (1989) cite nine investigations. Often fish communities reach their maximum populations size within a few months after the establishment of an artificial reef (TURNER 1969, STONE et al. 1979, BOHNSACK & TALBOT 1980, all in BOHNSACK & SUTHERLAND 1985). However, the establishment of a stable reef community, requires a period of between one and five years (BOHNSACK & SUTHERLAND 1985).

The assumption that increased biomass near artificial reefs is due to increased colonisation and growth of larvae is widespread; however, BOHNSACK et al. (1994) could not confirm this hypothesis. In fact, they found that reefs are basically colonised by juvenile or adult organisms. A basic model of increase and decrease of biomass on artificial reefs is given by BOHNSACK & SUTHERLAND (1985; Figure 9).

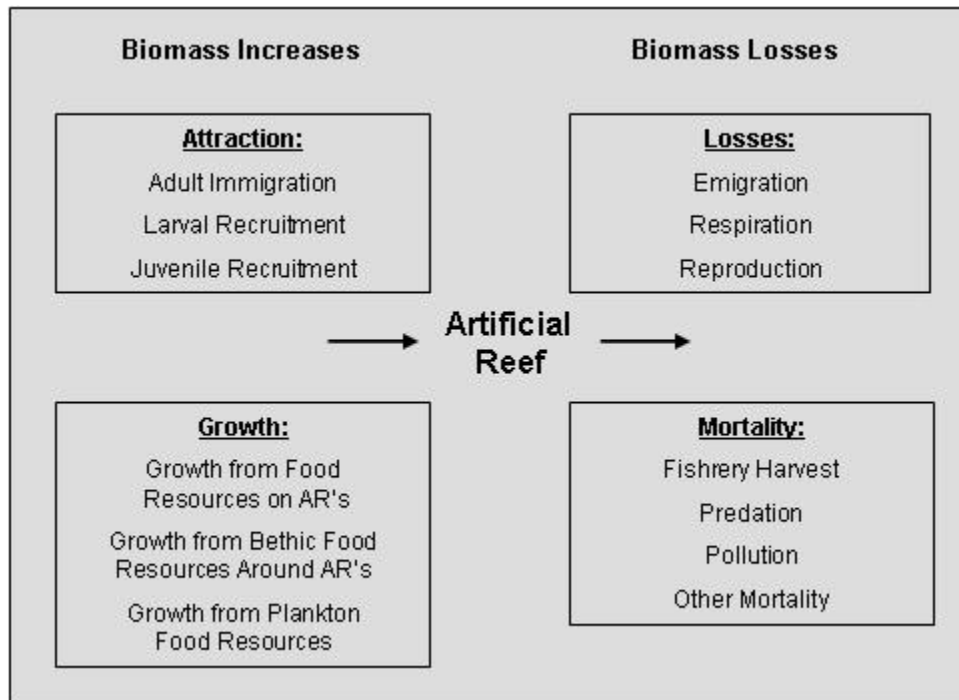

Figure 9: Basic model of increase and decrease of fish biomass on artificial reefs (from BOHNSACK & SUTHERLAND 1985).

Fish basically make use of artificial reefs in three different ways: Pelagic fish that swim towards the reef, but keep a certain distance from it (*Type A*); bottom dwelling fish that stay near the reef periodically, but usually not permanently (*Type B*); and demersal fish which constantly stay near the reef or its surrounding (*Type C*) (classification according to OGAWA 1982a, 1982b, in: BOHNSACK et al. 1985). According to BOHNSACK & SUTHERLAND (1985) migrating fish species form the major share of fish biomass in the surroundings of artificial reefs. By contrast, stationary species constitute only a small part of the increased catch rates.

RELINI et al. (1994) found fish populations on artificial reefs that were very similar to those communities found on natural hard substrate (see also CHARBONNEL 1990 in: RELINI et al. 1994). In comparing fish populations of ten artificial and sixteen natural reefs, AMBROSE & SWARBRICK (1989) also found that they coincided to a great extent, however, densities of benthic fish species were slightly higher on the artificial reefs. Moreover, the anthropogenic structures showed slightly higher diversity (AMBROSE & SWARBRICK 1989).

Basically, it is agreed that artificial reefs are highly attractive to fish (BOHNSACK & SUTHERLAND 1985, SEAMANN 2000 in: POWERS et al. 2003). Thus, AMBROSE & SWARBRICK (1989 in: HOFFMANN et al. 2000) observed a significant increase in the catch rates (catch per unit effort, CPUE) on artificial reefs. The same effect was described for Danish wreck fishery by KROG (1999 in: HOFFMANN et al. 2000) and for artificial reefs in Japan by GROVE et al. (1989).

The attraction of reef structures is attributed to the increased food supply, protection from predators, its function as a spawning ground, as a means of orientation, and as a refugee area from intensive fishery (BOHNSACK & SUTHERLAND 1985, DE SILVA 1989 in: NORSEKER 1997).

An open question remains whether the higher fish densities are due to a concentration of specimens that otherwise would dwell in other areas (concentration hypothesis), or if they are a result of truly higher productivity (production hypothesis) (BOHNSACK & SUTHERLAND 1985). BOHNSACK (1989 in: SVANNE & PETERSEN 1997) gives the following arguments to support the production hypothesis; however, these are supported by the literature only to a small extent:

- Artificial reefs increase the food availability;
- Artificial reefs increase the effectiveness of foraging;
- Artificial reefs give shelter from predators;
- Artificial reefs allow recruitment of larvae in areas of increased larval sedimentation which otherwise would be lost;
- Artificial reefs increase the production of natural reefs by providing additional substrate.

By contrast, the attraction hypothesis is supported by the investigations of BOHNSACK et al. (1994). The authors conclude from the results on artificial reefs off Florida that these do harbour a great number of fish, but neither cause a significant increase in production, nor create critical habitats for endangered species. Corresponding studies in Japanese coastal waters equally revealed a concentrating effect of artificial reefs for flatfish, but reefs did not increase the overall regional production (POLOVINA & SAKAI 1989). Because of the high mobility and the extended area over which fish populations are spread, it is difficult to be sure whether artificial reefs merely have an attracting effect on fish, or whether they actually increase fish biomass (GROSSMAN et al. 1997 in: POWERS et al. 2003). A comprehensive comparison between arguments for the attraction and production hypotheses of artificial reefs, respectively, is given by NORSEKER (1997).

Fish reactions to artificial reef structures can be broken down into five categories (THIERRY 1988 in: HOFFMANN et al. 2000):

- Rheotaxis: orientation on the basis of flow direction;
- Geotaxis: orientation with reference to the coast;
- Thigmotaxis: physical contact with the reef;
- Phototaxis: reaction to optical stimuli (light);
- Chemotaxis: reaction to olfactorical stimuli.

Also a reaction to acoustic stimuli is known (HOFFMANN et al. 2000).

In addition to such environmental factors as current patterns, the degree of colonisation by fish is affected primarily by the various characteristics of the hard substrate and the reef structure (BOHNSACK & SUTHERLAND 1985, BOHNSACK ET AL. 1991, KIM et al. 1994).

The most important factor for the effectiveness of an artificial reef is seen in its structure (KIM et al. 1994). The higher its complexity, the more effective an artificial reef will be (CHANG et al. 1977 in: BOHNSACK & SUTHERLAND 1985). Habitat complexity is defined as "number of units per area" (GREGG 1991 in: NORSEKER 1997). Surface condition and material composition can be of decisive importance for the composition and abundance of benthic organisms (NORSEKER 1997). Reef size is another important factor for biomass, density and species diversity. Smaller reefs have a higher density than larger ones, while larger reefs have higher biomass, formed by fewer but larger individuals (BOHNSACK et al. 1994). A direct correlation exists between reef volume of 400 m<sup>3</sup> to a maximum size of 4000 m<sup>3</sup> (OGAWA et al. 1977). YOSHIMUDA (1982 in: BOHNSACK &

SUTHERLAND 1985) proved that the attractiveness to fish increases with reef size. The height of an artificial reef is another important factor for its attractiveness to fish (KIM et al. 1994). However, BOHNSACK & SUTHERLAND (1985) pointed out that the reef height is of decisive importance only at water depths of > 40 m. GROVE & SONU (1983) note that the height is more important to migrating pelagic species than to stationary demersal species; for the latter, the horizontal spread of the reef is more important. Thus, it is a well-known fact that e.g. Gadidae (cod family) have a very strong affinity for vertical structures (CRIPPS & AABEL 1995 in: HOFFMANN et al. 2000). For demersal fish, a reef height of approx. 3 m is an important basic condition for increased attractiveness (BOHNSACK et al. 1991, POLOVINA & SAKI 1989).

Regardless of the reef's design, the location of an artificial reef is an important factor for its significance for fish (OGAWA 1982b, KUWATANI 1982 both in: BOHNSACK & SUTHERLAND 1985).

The impact range of an artificial reef is assumed to be 200 - 300 m for pelagic and 1 - 100 m for demersal species (GROVE et al. 1989). Directed movements of flounders (*Platichthys flesus*) were observed between neighbouring reefs which were installed at intervals of >900 m (GROVE et al. 1989). For common dab (*Limanda limanda*) and sole (*Solea solea*), action ranges of up to 600 m around a reef were observed (GROVE et al. 1989). Significant increases of the abundance of hard-substrate-dwelling fish occurred when the intervals were <400 m (GROVE et al. 1989). A review of the sensory distance of various fish species from artificial reefs is given by GROVE et al. (1983 in: NORSKER 1997; Table 12).

Table 12: Sensory distance of various fish species to artificial reefs (from GROVE et al. 1983 in: NORSKER 1997).

Fisk	sensorisk afstand til rev	aggregater observeret
crimson seabream	20-40 m	
red seabream	30-40 m	
seabream spp	50-60 m	
leatherfish	70 m	
rockfish (demersale)	200 m	
sole, flounder (ant. Jap.)		100-600 m
rockfish, rabbitfish		for I <1870 m.: flest <370 m.
typical range of influence	"order of hundreds of meters."	

### 5.3.1 Offshore Wind Farms

The submerged structure of an offshore wind turbine can be considered an artificial reef (WESTERBERG 1994, STØTTRUP & STOKHOLM 1997, HOFFMANN et al. 2000).

An initial assessment of the impacts to be expected by offshore wind farms on the fish fauna was made in Denmark at the Horns-Rev wind farm. There, the turbines are built on monopiles 3.5 m in diameter each. The foundation surface is of steel (HOFFMANN et al. 2000). In terms of surface roughness, this foundation type can be compared to those of oil and gas platforms in the North Sea (HOFFMANN et al. 2000). Monopiles of wind turbines have significantly less complexity than the open grid structures of the jacket-like foundations of oil and gas platforms (HOFFMANN et al. 2000). Likewise, the turbine foundations show significant differences in structure compared to artificial reef

complexes which serve fishery interests. They show a compact, vertical profile from the seafloor to the surface of minor complexity, and low surface smoothness. In agreement with the general comments on the importance of complexity (Chapter 5.3), HOFFMANN et al. (2000) assume that with regard to fish fauna, the effectiveness of a turbine foundation will be less than that of such complex reef structures as gas and oil platforms.

However, the vertical dimension supports a broad habitat area that allows various benthic species and macrophytes to settle at their respective optimal water depths (HOFFMANN et al. 2000).

The scour protection, by contrast to the foundations, offers a low profile, but high complexity and roughness. This structure provides great habitat complexity due to the large number of holes of various sizes on its extensive surface, and therefore forms the basis for high biodiversity (HOFFMANN et al. 2000).

On the base of the available background information (Chapter 5.3) as well as the observations on oil platforms (Chapter 5.3.2) with regard to species-specific reactions from those species dwelling in the Horns Rev area, HOFFMANN et al. (2000) assume that especially species of the cod family (Gadidae), e.g. the whiting (*Merlangius merlangus*) and the Atlantic cod (*Gadus morhua*), will be attracted by the vertical dimension of the foundation. On the other hand, an attraction effect for flatfish dwelling in the region, e.g. the plaice (*Pleuronectes platessa*), was expected from the scour protection (HOFFMANN et al. 2000).

The available monitoring investigations at Horns Rev (LEONHARD & PEDERSEN 2004) to date confirm the initial prognosis. In the course of these studies, during the first year after the construction of the wind farm, two fishing campaigns (spring and fall) were carried out with anchored gillnets in the area of six selected turbines. Again in the spring of 2004, gillnets were placed on the turbine foundations (Figure 10). All species caught in the gillnets (Table 13) were also registered by divers.

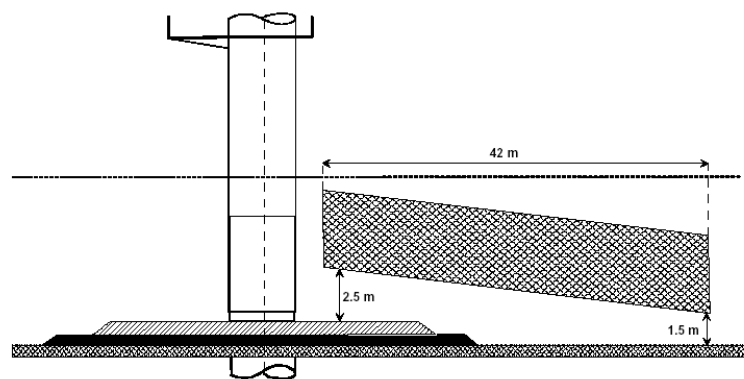

Figure 10: Sampling design of anchored gillnet catches on selected wind turbine foundations at Horns Rev (from LEONHARD & PEDERSEN 2004).



Table 13: Results of gillnet catches at Horns Rev (from LEONHARD 2005)

		March 2003	September 2003	March 2004
<b>Numerous</b>				
<b>Common name</b>	<b>Scientific name</b>			
Atlantic cod	<i>Gadus morhua</i>		X	
Bib	<i>Trisopterus luscus</i>		X	
Rock gunnel	<i>Pholis gunnellus</i>	X	X	X
Goldsinny-wrasse	<i>Ctenolabrus rupestris</i>		X	
Crockwing wrasse	<i>Symphodus melops</i>		X	
Sand goby	<i>Pomatoschistus minutus</i>		X	
<b>Common</b>				
<b>Common name</b>	<b>Scientific name</b>			
Horse mackerel	<i>Trachurus trachurus</i>		X	
Dragonet	<i>Callionymus lyra</i>		X	
Viviparous blenny	<i>Zoarces viviparus</i>	X	X	X
Hooknose	<i>Agonus cataphractus</i>	X	X	X
Shorthorn sculpin	<i>Myoxocephalus scorpius</i>		X	X
<b>Observed</b>				
<b>Common name</b>	<b>Scientific name</b>			
Whiting	<i>Merlangius merlangus</i>		X	
Saithe	<i>Pollachius virens</i>		X	X
Striped red mullet	<i>Mullus surmuletus</i>		X	
Lumpsucker	<i>Cyclopterus lumpus</i>			X
Longspined bullhead	<i>Taurulus bulbaris</i>			X

The bib (*Trisopterus luscus*), the cod, and whiting shoals probably fed on crustaceans on the scour protections. Individuals of butterfish (*Pholis gunnellus*) and dragonet (*Callionymus* spp.) were frequently found in caves and clefts between the stones of the scour protection (LEONHARD & PEDERSEN 2004). Similar observations have been made in other studies (LEEWIS & HALLIE 2000 in: LEONHARD & PEDERSEN 2004).

The small number of species observed during the spring of 2004 is explained by LEONHARD (2005, pers. comm.) by the harsh weather conditions. In the autumn of 2004 (results not yet published) more species were observed. Compared to the previous year (autumn 2003) the number of species increased even more. Even some species which had previously not been detected could be verified in the Horns Rev area (LEONHARD 2005, pers. comm.).

In regard to literature statements on the impact range of artificial reefs (see above), the distances between the foundations in the Horns Rev wind farm of 550 m are within the sensory range of flatfish.

In the pre-construction phase of the wind farm, HOFFMANN et al. (2000) assumed that no permanent fouling would grow on the plant's foundations due of the hydrographic conditions in the Horns Rev area. The authors considered a potentially increased food supply, forming the basis of the fishes' further food web, to be of minor importance. However, the monitoring carried out after the construction according to preliminary calculations revealed an eight-fold increase of food availability for fish (LEONHARD & PEDERSEN 2004). The authors therefore do not exclude the possibility that the increase of fish production registered in the fall of 2003 is associated to the presence of the hard substrate.

By means of hydroacoustic monitoring the density and distribution of fish was registered in Horns Rev wind farm in October 2004 (HVIDT et al. 2005). At the time of the survey, only little effect on fish abundance was found from the wind farm or the hard bottom substrate. Significantly higher densities of fish in connection with the turbine foundation

were found in one out of four transects. The results indicate that offshore wind farms attract fish beyond a distance of 500 m (HVIDT et al. 2005).

Previous studies at the Nysted wind farm have been obviated due to a lack of data density (ENERGIE E2 2002).

The reef effect on non-pelagic fish species was investigated at three offshore wind turbines in Utgrunden (southern Kalmar Sound, 10 km offshore) and at five offshore wind turbines near Yttre Stengrund (4 km off the eastern coast of Blekinge) (MALM 2005). All foundations are steel monopiles (diameter 10-12 m). The sediment consists of sand and gravel with additional stones and boulders at distances of about 2 m from the foundation (MALM 2005). In the direct vicinity of the foundations, large shoals of two-spotted gobies (*Gobiusculus flavescens*) could be observed, mostly larvae. Their abundance rapidly decreased with distance from the foundations (MALM 2005). The shoals occurred from the surface up to water depths of 3-4 m (6-8 m absolute depth) at the foundation (MALM 2005).

In the sandy substrate close to the foundations (< 20 m), such species as the sand goby (*Pomatoschistus minutus*), the black goby (*Gobius niger*) and the eelpout (*Zoarces viviparus*) occurred in higher frequencies than at distances between 20 m and 2 km (MALM 2005). Consequently, the fish community close to the turbines was characterised by greater diversity and abundance than that at a distance of 20 m (MALM 2005). This reef effect was restricted to the direct foundation area, since the fish community was not affected in the area between 20 m and 2 km away. Therefore, MALM (2005) assumes that no wind farm effect will occur.

In the course of investigations on the test turbine Svante 1 in Nordersund, Sweden, WESTERBERG (1994) could make no final statement as to whether the observed fish densities were affected by an attracting effect of the turbine's steel tripod foundation, since no reference studies had been undertaken prior to construction of the turbine.

Referring to the literature (Chapter 5.3) SMITH & WESTERBERG (2003) pointed out that a possible attraction effect on predators could indeed negatively affect the reproduction rate of many target species. This is especially true if wind farms are built in typical nursery grounds (SMITH & WESTERBERG 2003).

BOHNSACK & SUTHERLAND (1985) state that the high fish densities in the surroundings of artificial reefs are mainly due to a concentration of attracted fish. As a conclusion, PETERSSON (2000) postulates a significant correlation between the size of fish populations and the possible interdiction of fishing in the wind farm areas. Commercially exploited species gathering in the wind farm area because of its attracting effect could easily be even more overfished if fishing were allowed (PETERSSON 2000, SMITH & WESTERBERG 2003, DOLMER et al. 2002). On the other hand, wind farm areas might act as a refuge area for fish, and therefore have a positive effect on the fish population (PETERSSON 2000).

Finally it must be noted that most actually planned offshore wind farms will be located in water depths of up to 40 m. According to the state of the art, jacket or tripod foundations will preferably be used at these depths. Due to their greater complexity, they bear much greater similarity to the foundations of oil and gas platforms than do the monopile foundations at Horns Rev. Based on the available information, a larger reef effect may be assumed for these foundations. In addition, the vertical profile of the turbines would be more important (see Chapter 5.3).

Based on the state of the art, most wind farms are planned with larger turbines (> 4 MW) than the Horns Rev wind farm (2 MW turbines). Thus, increased intervals are

required between turbines to ensure optimal wind conditions, without negative effects from the turbulence of other turbines. An interval of approx. 800 m is required for 4.5 MW turbines with rotor blade diameters of 112 m (KAFEMANN et al. 2003). The literature (Chapter 5.3) suggests that each single foundation acts as a separate artificial reef. Therefore, interactions between the separate foundations might involve at most some demersal species, like the flounder.

If the turbines are built without scour protection, the expected reef effect will probably be reduced. This is especially true for demersal species.

### 5.3.2 Oil and Gas Exploitation

To date, some 420 large structures have been installed in the North Sea (PEARCE 1995 in: ANTHANASSOPOULOS 1999), of which 209 are Norwegian oil production installations (47 in water depths of >100 m) (KNOTT 1995 in: ANTHANASSOPOULOS 1999). On the British continental shelf, 250 offshore structures have been permanently installed, with about 100 of them situated in water depths of more than 40 m (PICKEN & MCINTYRE 1989). These structures also serve as artificial reefs (VALDEMARSEN 1979, PICKEN & MCINTYRE 1989 SOLDAL et al. 1998; 2002, LØKKEBORG et al. 2002, JØRGENSEN 2002, BAINE 2002).

The reef effect of offshore oil and gas platforms is best analyzed for the Norwegian Ekofisk platform in the central and northern North Sea. Important studies have been undertaken by VALDEMARSEN (1979) and SOLDAL, LØKKEBORG, JØRGENSEN et al. (1998, 2002), who analyzed fish distribution on the Ekofisk complex or on individual platforms (Albuskjell and Gullfask).

The gillnet catch rates of Atlantic cod (*Gadus morhua*) and pollack (*Pollachius pollachius*) were on average 3-10 times higher close to the platform (0-200 m) than > 500 m away (VALDEMARSEN 1979).

SOLDAL et al. (1998, 2002) also registered increased gillnet catches (79% Atlantic cod, 20% pollack) when approaching the platform (Albuskjell) (LØKKEBORG 2002, SOLDAL 1998, 2002). During sampling in May and July, significantly increased catch rates (by a factor of 3) were found at a distance of 110 m, as compared with farther away. Within a distance of less than 55 m, these values were doubled once more. In autumn (September), higher densities were registered in an area 300 m from the platform, with the highest values occurring at a distance of 150-300 m. In order to explain this change of distribution pattern, LØKKEBORG et al. (2002) assume that the necessity to stay in the immediate platform area decreases for many species with increasing fish density. In accordance with the observations of fishermen, the authors also assume that the bad weather conditions in autumn make it more difficult for the fish to stay close to the platform.

Similar distribution patterns were recorded for the ling (*Molva molva*), the dominating species at the Gullfask platform (LØKKEBORG et al. 2002). Gillnet catches revealed fourfold higher catches within a radius of < 165 m from the platform as compared to areas farther away. These values were doubled once more within a closer range (55-110 m). Cod and pollack, however, were only caught in small numbers without any obvious distance gradient. LØKKEBORG et al. (2002) attribute these differences to the differences in foundation and sediment structure of the two platforms. The Albuskjell platform is an open steel foundation situated in water depths of 70 m on homogeneous clayey sandy bottom. Contrary, the Gullfask platform has a concrete foundation built on a depth gradient with a heterogeneous muddy sandy and stony bottom in water depths

of 200 - 230 m. LØKKEBORG et al. (2002) conclude that artificial reef structures in a relatively shallow homogeneous environment seem to be more attractive to migrating species like cod and pollack than more heterogeneous regions. Regarding the high densities of cod on the Albuskjell platform, the authors furthermore assume that the steel structure's higher complexity leads to an increased attraction effect (see chapter 5.3).

Mackerel (*Scomber scombrus*) and pollack (*Pollachius pollachius*) at the Albuskjell platform showed less affinity for the reef than cod; both were observed in shoals and in varying water depths (mostly 30 m) around the platform, while cod were mainly seen stationary in high densities close to the bottom of the platform (1-2 m above sea bottom). Highest densities were registered in the lower 10 m of the foundation. Fish concentrations decreased significantly at a distance of only a few meters from the platform, sometimes below their regional average densities (SOLDAL et al. 1998).

This result has been confirmed by video surveys at other platform foundations (CRIPPS & AABEL 1995 in: SOLDAL 2002, PICKEN & MCINTYRE 1989). The latter found pollack dominant in the upper 40 m, while it was less frequent at depths of 40-80 m. There, cod and haddock (*Melanogrammus aeglefinus*) were more abundant. Maximum densities were registered at the foundation footing (mostly at depth of about 100 m) and the 15 m above (PICKEN & MCINTYRE 1989).

JØRGENSEN et al. (2002) confirmed the strong affinity of cod to the foundation (Albuskjell) by acoustical tagging. Half of the twenty-nine tagged individuals stayed exclusively in the immediate vicinity of the foundation during the three months of the survey. However, cod sporadically left the reef structures, as was revealed by the catch of two tagged individuals in the center of the Ekofisk complex (13 km away from the platform), as well as recordings of four specimens at a neighbouring platform (8 km away).

The stomach content of 46 cod was examined in order to pursue the question of trophic dependence on the reef's fouling (VALDEMARSEN 1979). In addition to their usual food, such as sand eel and krill (*Meganycthiphantes norwegicus*), other elements of platform fouling were found. By contrast, JØRGENSEN et al. (2002) could not prove any difference in food composition between platform-associated and open-water individuals.

SOLDAL et al. (1998) assume that fishes that perceive the platform's presence when approaching in most cases are attracted and actively swim towards the foundation. The authors use the image of a vacuum that absorbs fish from the surroundings. Most important for the fish are prey density and the flow protection (LØKKEBORG et al. 2002). This is shown by the dominance of large Gadidae and, especially in the case of cod, the persistence in the current regime of the platform (LØKKEBORG et al. 2002).

Referring to the CPUE of <3 kg/net in the Albuskjell region, SOLDAL et al. (1998) conclude that the number of fish on a single platform is too small to have measurable effects on the fish population of the North Sea. The primary limiting factor is the foundation size, not the surroundings (SOLDAL et al. 1998). As mostly piscivorous species were found in the reef area, the authors consider its potential as a protected area for the maintenance and development of fish populations to be rather low.

More investigations of oil and gas platforms have been undertaken in the Gulf of Mexico and the coast of California than in the North Sea. Those platforms are also colonised by various species communities, including fish species and invertebrates typical of natural reefs (HOLBROOK et al. 2000). The density of some species was higher near the platforms than on natural reefs (CARR et al. 1999 in: HOLBROOK et al. 2000, CARR et al.

2003). Due to differing local fish populations and local conditions, these investigations allow only limited conclusions on the impacts of artificial reefs in the North and Baltic Seas (PICKEN & MCINTYRE 1989, LØKKEBORG et al. 2002, JØRGENSEN et al. 2002). Nevertheless some basic conclusions can be drawn, regardless of species.

In both regions, the vertical profile of the foundation, divided into segments (upper, middle, lower part), is of varying importance for fish in their respective developmental stages (egg, larvae, juvenile, adult). LOVE et al. (2000) found that the middle segments of seven offshore oil platforms off Santa Barbara, California, were colonised mainly by 0-group individuals, juveniles or individuals of up to two years' age. By contrast, near the bottom, mostly larger subadult to adult specimens were found. The density was independent of water depth, so that the biomass near the bottom was also higher (LOVE et al. 2000). Due to the higher habitat variability, the species composition was more diverse on the bottom than in mid-water (LOVE et al. 2000). Comparable results were obtained by CARR et al. (2003).

HOLBROOK et al. (2000) also prove that various fish species can be found at different depths of the platforms. The upper 20 to 30 m of the oil platforms were basically inhabited by algae, early developmental stages of fish and sessile invertebrates. This is due to the rapid light attenuation with increasing water depth and the depth-dependent stratification of the larvae of many species (Figure 11) (HOLBROOK et al. 2000).

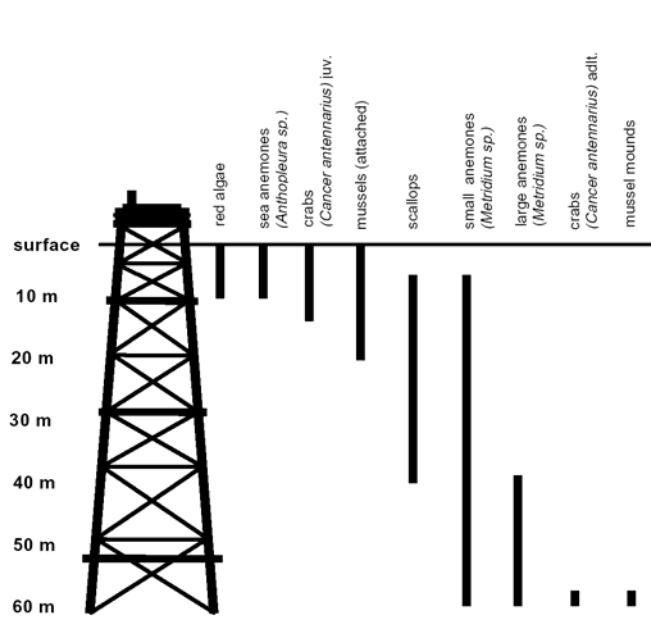

Figure 11 Vertical distribution of invertebrates on the foundation of an offshore platform in California (from PAGE et al. 1999 in HOLBROOK et al. 2000).

On the upper part of the foundations, adult fish of typical shallow water areas could also be registered. Furthermore, the authors point out that many species use the platforms depending on their developmental stage. E.g. demersal species are initially restricted to the upper parts of the foundation, and do not colonise the lower parts until they have reached the subadult or adult stage (Figure 12).

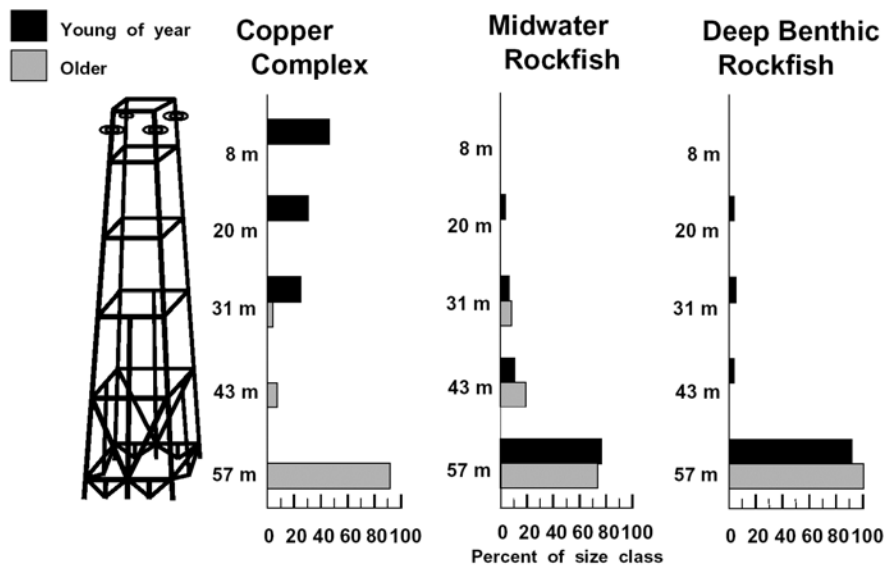

Figure 12: Vertical distribution of various fish species complexes dependent on their age (from CARR et al. 1999 in: HOLBROOK et al. 2000).

Pipelines and scour protection also form artificial hard substrates (HOLBROOK et al. 2000). In areas where pipelines are not buried, they are also inhabited by many species, and thus can initiate reef-like biocoenosis in areas with mainly sandy substrates.

The importance of oil and gas pipelines for fish fauna and fisheries was investigated by a Norwegian study with active trawl catches and passive gillnet catches (NØTTESTAD 1998). Previously, the community structure and the fish density in the pipeline area were determined by means of video recordings (NØTTESTAD 1998). Shallow waters as well as deep waters were analyzed. The studies were restricted to spring, thus seasonal differences were not considered (NØTTESTAD 1998).

High concentrations of small fish at the pipeline and its immediate surrounding (<1 m distance) were observed (DOLMER et al. 2002). This was attributed to the pipeline's capacity of protection from predators and currents. On the other hand, DOLMER et al. (2002) assume that close to the pipelines the food supply for fish was higher, due to increased sedimentation of organic material.

Trawl catches close to the pipeline were no higher than those in control investigations at a distance of 2.5 nmi. Different results were achieved by test fishing with gillnets (DOLMER et al. 2002), which yielded a catch rate in the pipeline area (66% of total catch) significantly higher than that in the reference area (34% of total catch) (DOLMER et al. 2002). However, if merely commercially exploited fish species were considered, only a minor aggregation effect could be registered in the surroundings of the pipelines (NØTTESTAD 1998).

## 5.4 Electromagnetic Fields

Electric cables in the sea can be operated by means of three-phase current or direct current, depending on circuit distance. Three-phase current cables cannot be used cost-efficiently at distances of more than approx. 150 km, due to higher transmission loss. Thus, direct current cables are required at greater distances (DENA 2005).

Magnetic and electric fields are induced outside the underwater cable by the current flow through the cable. Potential impacts on fish are to be expected if the cable-induced electromagnetic fields overlap with species-specific sensitivity thresholds.

According to FRICKE (2000), magnetic fields can potentially affect the orientation of marine fish during their migrations or even redirect their migration. Electric fields can have scaring effects on marine fish and probably also redirect their migration pattern (Chapter 5.4.1).

Nearly all fish species in the North and Baltic Seas perform local or long distance migrations during their life cycle. FRICKE (2000) distinguishes the following migratory patterns of fish (Table 14):

Table 14: Migratory movements of selected fish species in the North and Baltic Seas (compiled according to FRICKE 2000).

Migratory movement	Selected species	
	Common name	Scientific name
Short distance, close-to-bottom seasonal migrations of adults	Dragonets Flatfish	<i>Callionymidae</i> <i>Pleuronectidae</i>
Short distance, tide-dependent migrations of adults in estuaries		
Short distance, tide-dependent migrations of fish larvae and drifting of fish eggs in estuaries	Twait shad	<i>Alosa fallax</i>
Long distance feeding migration	Herring Anchovy Porbeagle Sardine Mackerel John dory Thresher shark	<i>Clupea harengus</i> <i>Engraulis encrasicolus</i> <i>Lamna nasus</i> <i>Sardina pilchardus</i> <i>Scomber scombrus</i> <i>Zeus faber</i> <i>Alopias vulpinus</i>
Long distance spawning migration	Herring	<i>Clupea harengus</i>
Anadromous spawning migration	Sturgeon Allis shad Twait shad River lamprey Sea lamprey	<i>Acipenser sturio</i> <i>Alosa alosa</i> <i>Alosa fallax</i> <i>Lampetra fluviatilis</i> <i>Petromyzon marinus</i>
Katadromous spawning migration	European eel	<i>Anguilla anguilla</i>

### 5.4.1 Electric Fields

The general impacts of electric fields on fish are well-known. According to STERNIN et al. (1976 in: FRICKE 2000), three impact phases can be distinguished: scaring effect, redirection and torpidity (Figure 13):

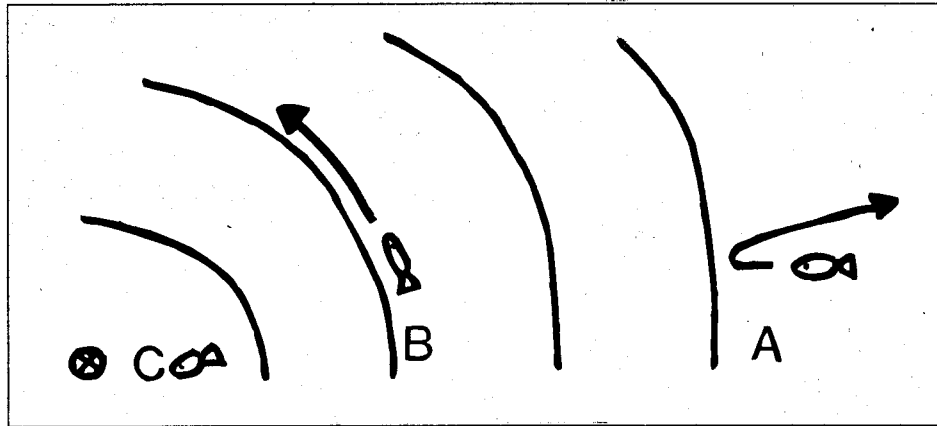

Figure 13: Impacts of electric fields on fish: x = power source, A = scaring effect, B = redirection, C = torpidity (from STERNIN et al. 1976 in: FRICKE 2000).

The strength of the electric field that causes a reaction according to phases A-C (see Figure 13) varies depending on the fish species' sensitivity and the size of the fish (FRICKE 2000).

Electro-sensitive fish use their electroreceptors, the Lorenzian ampullae, for prey detection (HEYER et al. 1981 in: POLÉO et al. 2001), for spatial orientation and probably for navigational purposes.

Most fish detect electric fields by passive reception of low-frequency electric gradients (GILL & TAYLOR 2001). Especially elasmobranchs and eels are known to have this ability (BULLOCK 1973 in: GILL & TAYLOR 2001).

The lowest thresholds for electric fields have been proved for elasmobranchs (sharks and rays) and cyclostomata (lampreys) (KALMIJN in: WILTSCHKO & WILTSCHKO 1995). Elasmobranchs react even to very weak electric fields ( $< 0,005 \mu\text{V}/\text{cm}$ ) by detectable behavioural changes (HEYER et al. 1981, KALMIJN & KALMIJN 1981, KALMIJN 1982, all in: POLÉO et al. 2001). This implies that the sensitivity of elasmobranchs to electric fields is about 14000 times higher than that of bony fishes (see below) (MARINO & BECKER 1977).

The European eel is the species best investigated of the bony fishes (Teleostei) for species-specific reactions to weak electric fields (POLÉO et al. 2001). However, the literature evaluated by the authors reflects very different opinions. While MCCLEAVE et al. (1971 in: POLÉO et al. 2001) registered behavioural reactions in eels at field strengths below  $0.4 \text{ mV}/\text{m}$ , ENGER et al. (1976) note minimal field strengths of  $40 \text{ mV}/\text{m}$ . MARINO & BECKER (1977) observed reactions in eels and salmon to field strengths between  $7$  and  $70 \text{ mV}/\text{m}$ . Since some scientists doubt the validity of the extremely low thresholds found by MCCLEAVE et al. (BERGE 1979, KALMIJN 1984), POLÉO et al. (2001) also assume  $7 \text{ mV}/\text{m}$  to be the lowest threshold of bony fishes.



According to FRICKE (2000), in the German North Sea and in the Baltic Sea, impacts of electric fields on the following species groups are to be expected:

- the herring family (Clupeidae),
- sharks and rays (Elasmobranchs),
- flatfishes (Pleuronectidae),
- other demersal migratory bony fishes (Teleostei).

It is well-known from electric fishing in fresh water that not only adults, but also eggs and larvae of many fish species react very sensitively to electric fields. Therefore, they have to be adequately considered in the assessment of possible impacts of artificial electric fields in the ocean (FRICKE 2000).

#### 5.4.1.1 Offshore Wind Farms

The effects of electromagnetic fields generated by the power grid connection on elasmobranchs (lesser spotted dogfish) were investigated in a model test by GILL & TAYLOR (2001). Avoidance behaviour of the animals was observed at field strengths of 1000  $\mu\text{V}/\text{m}$ . This corresponds to the maximum electric emission of a 150 kV cable with an amperage of 600 A. However, attraction effects were observed at field strengths of 10  $\mu\text{V}/\text{m}$ . The attraction effect of the lower field strength is explained by the fact that this corresponds to the field strength that typical prey animals emit by their physical movements.

Based on the studies of GILL & TAYLOR (2001) the CENTRE FOR MARINE AND COSTAL STUDIES (CMACS) (2003) simulated the electric field strengths of a triple core 132 kV XLPE three-phase cable buried in 1 m depth in the sediment. The strength of the resulting electric field in the sea water above the cable was calculated to be 91  $\mu\text{V}/\text{m}$ . Thus, the simulated electric field is in a range where elasmobranchs are attracted as well as scared (GILL & TAYLOR 2001). Even at a distance of 20 m to the cable (horizontally and vertically), the electric field is still in the same order of magnitude like the sensitivity of many elasmobranchs (CMACS 2003).

Additional calculations of induced electric fields with data of in situ measured magnetic fields were within the lower perception range of elasmobranchs (CMACS 2003).

#### 5.4.1.2 Magnetic Fields

Many marine fish species use the earth's magnetic field, including magnetic field anomalies, for their orientation during migration (Table 14) (FRICKE 2000). This orientation is of major importance during migration when bottlenecks like the British Channel in the North Sea have to be passed (FRICKE 2000).

The sensitivity of fish to magnetic fields is comparable to that to electric fields (POLÉO et al. 2001). According to the current state of knowledge, the impacts of magnetic fields are restricted to the orientation and navigation of fish. No indications of negative effects of different magnetic field strengths were found in the literature evaluated in this report.

Basically, the way fish detect magnetic fields is still unclear. Currently, there are three different theories on magnetic field reception in fish (BEASON 1997, LOHMANN & JOHNSEN 2000):

1. electromagnetic induction
2. chemical magnetic field reception
3. reception by magnetic material (e.g.  $\text{Fe}_3\text{O}_4$ ) in animals.

The inductive approach is the most thoroughly investigated and the best-known for elasmobranchs as well as roundmouths and chimaerae (POLÉO et al. 2001).

In bony fish, the ability to perceive magnetic fields is best documented for eel (BRANOVER et al. 1971, MCCLEAVE & POWER 1978, SOUZA et al. 1988, TESCH et al. 1992, WESTERBERG 2000a) and various salmon species (VARANELLI & MCCLEAVE 1974, QUINN & BRANNON 1982, TAYLOR 1986a, b, CHEW & BROWN 1989, WALKER et al. 1997).

There is extensively documented evidence that elasmobranchs already perceive weak magnetic fields comparable to the earth's magnetic field, and react to them (KALMIJN 1966, KALMIJN 1977, KNUDTSON & STIMERS 1977 GOULD 1984, all in: POLÉO et al. 2001). POLÉO et al. (2001) furthermore specify a number of studies (e.g. KALMIJN 1977, 1982, 1988) which have proved behavioural changes as a result of small changes in the magnetic field. However, basic parts of these investigations were made in aquaria or over short distances in open waters (POLÉO et al. 2001). Thus, the results can only partly be generalised to animals in their natural habitat.

According to the relevant literature, the question as to whether bony fish also use the earth's magnetic field for orientation or navigation is still uncertain. Studies by POLÉO et al. (2001) revealed that the fry of sockeye salmon (*Oncorhynchus nerka*) do not show reactions to small changes of the magnetic field (BRANNON et al. 1981). The same is true for juvenile dog salmon (*Oncorhynchus keta*) (QUINN & GROOT 1983), free-swimming dog salmon (YANO et al. 1997, MARHOLD & KULLNICK 2000), and Atlantic salmon (*Salmo salar*) (MCCLEAVE ET AL. 1971, ROMMEL & MCCLEAVE 1973, VARANELLI & MCCLEAVE 1974). These results contradicted other studies, which showed effects on slightly older fry and smolts of the sockeye salmon (QUINN 1980, QUINN & BRANNON 1982) and for rainbow trout (*Oncorhynchus mykiss*) (TAYLOR 1986b, CHEW & BROWN 1989, WALKER et al. 1997). A magnetic orientation and thus a potential impact of artificial anomalies of the earth's magnetic field is assumed to be possible by FRICKE (2000) for allis shad (*Alosa alosa*), twait shad (*Alosa fallax*), Atlantic pomfret (*Brama brama*), herring (*Clupea harengus*), sardine (*Sardina pilchardus*) and Baltic sprat (*Sprattus sprattus*).

The results on the effects of magnetic fields on eels are inconsistent as well. Various investigations are cited by POLÉO et al. (2001) that support the view that eels react to small changes of the magnetic field by behavioural reactions. Other studies, by contrast, could prove no behavioural reactions. KARLSSON (1985 in: WESTERBERG 2000a) and TESCH et al. (1982 in: WESTERBERG 2000a) assume on the basis of previous laboratory experiments that eels already reacts to changes of the magnetic field in the same magnitude as the earth's magnetic field. Definite reactions in eels, however, are only proven for very high field strengths (POLÉO et al. 2001). Eels exposed to high magnetic field strengths showed higher activity levels (VASILYEV & GLEYZER 1973). With increasing distance to the magnetic source and thus decreasing field strength, the activity level decreased once again. This behavioural pattern implies that the animals were disturbed by the magnetic field.

In the course of planning the SwePol HVDC cable from Sweden to Poland, laboratory experiments were made with glass eels which were temporarily exposed to an artificial magnetic field (WESTERBERG 2000a). The induced magnetic field exceeded the natural magnetic field maximal by a factor of fifty. Even at the maximum level, the animals showed no significant reactions. Thus, WESTERBERG (2000a) assumes that cables that locally increase the magnetic field to 100  $\mu$ T (approx. twice the earth's natural magnetic field in the North and Baltic Seas) does not imply a significant barrier effect for glass eels.

Comparable investigations were carried out by FOCK et al. (1999 in: MARHOLD & KULLNICK 2000) for the EuroKabel/VIKING Cable (North Sea). The highest exposure levels in this laboratory experiment were 161.4  $\mu\text{T}$ , corresponding to 1 m vertical distance from the jetted cable. Even at this level, more than 85% of the glass eels crossed the artificially induced magnetic field. Regarding the potential barrier effect of the HVDC cable, the authors therefore agree with WESTERBERG (2000a).

Similar results were achieved by the field studies of WESTERBERG & BEGOUT-ANRAS (2000). In 1997 and 1998, the authors investigated the migration behaviour of twenty-five transmitter-tagged silver eels in the surroundings of an HVDC cable (Baltic Cable) using DGPS and hydrophones. A current of 1000-1300 A flowed constantly through the cable, inducing a magnetic field of 5  $\mu\text{T}$  (10% of the earth's magnetic field) at a distance of 60 m from the cable. The sound recordings revealed that about 60% of the transmitter-tagged eels crossed the cable in spite of the clear anomaly to the natural magnetic field. Only marginal changes in swimming direction while crossing of the cable indicated an effect of the cable. A permanent barrier effect due to the cable is therefore excluded by WESTERBERG & BEGOUT-ANRAS (2000).

#### 5.4.1.3 Offshore Wind Farms

Referring to the power grid connection of offshore wind farms, WESTERBERG (1994) investigated changes in the migration behaviour of silver eels in the surroundings of the offshore wind turbine Svante 1 in Norgesund, Sweden. Regardless of the turbine's operational status (activated or deactivated), no definite proof of changes in the eels' behaviour was found. However, no movements of eels closer than 500 m to the turbine were registered during the test phase, thus disturbance within a distance of less than 500 m cannot be excluded.

During the monitoring program for the Nysted wind farm, HVIDT et al. (2004) compared the distribution (weight and number) of selected fish species (especially eel) on both sides of the cable lines to the power grid connection. The data obtained during the pre-operational phase of the wind farm were compared to those collected during the operational phase; no significant differences were found. The total distribution of indicator species did not differ from the natural variety before installation and operation of the cable. Based on these results, however, the authors could not decide whether or not the magnetic field of the cable in fact affected the fish or induced a barrier effect. On the one hand, the data collected showed too much variation, on the other, the investigation period was too short (HVIDT et al. 2004). Moreover, due to the test design selected, the direct vicinity of the cable (< 300 m) was not included in the investigation. Thus, the specific reaction of fish crossing or swimming away directly at the cable could not be evaluated (HVIDT et al. 2004).

In conclusion, it should be noted that WILTSCHOK & WILTSCHOK (1995) point out that many organisms usually do not rely exclusively on only one sense organ for their spatial orientation, and probably can compensate reactions to magnetic fields by using other sense organs. Quinn (1980 in: MARHOLD & KULLNICK 2000) proved that juvenile sockeye salmon (*Oncorhynchus nerka*) reacted to an artificial change of the earth's magnetic field only if they were not able to see the sky. KULLNICK & MARHOLD (2000) state that a migration mechanism of eels based on only one factor would be contradictory to the intraspecific constancy of the migration route. As non-magnetic migration mechanisms are known in glass eels (negative phototactic), yellow eels (positive rheotactic) and silver eels (negative rheotactic), KULLNICK & MARHOLD (2000) assume that eels also have developed a multifactorial orientation system (WESTERBERG & BEGOUT-ANRAS 2000).

## 6 Discussion

The following chapter summarises the results of the present literature review. For better readability, repetition of citations with the respective statements has been dispensed with. For attribution of statements, please refer to the preceding chapters.

The report summarises investigations that have been performed in the context of the assessment of the impacts of offshore wind farms on marine fish fauna. Special emphasis of the evaluation is on direct investigations at existing wind farms. The compilation has documented that the general knowledge base is still incomplete. Therefore, investigations on the effects of other forms of marine utilisation are also evaluated. In cases where no specific results are available, conclusion by analogy offers the best estimate of possible effects. Hence, results of fundamental research are also presented.

### Monitoring Investigations

After the construction of wind turbines, monitoring investigations must be carried out to evaluate and, if necessary, improve the quality of the previous assessments. In Germany, this will be done according to the "EIA Standards" stipulated by the Federal Maritime and Hydrographic Agency (BSH). The standards, developed by the approval authority in consultation with several external scientists, constitute a framework of minimum requirements for marine environmental surveys and monitoring. The first version, published in 2001, was revised in 2003, and a further revision is carried out presently (in 2005). Investigations take place in every project area, and include an adequate reference area. Depending on the marine habitat, investigations of fish fauna are to be carried out with different fishing gear (beam trawl, otter trawl, or a combination of both). Monitoring investigations use the same methods as the baseline investigation during the pre-construction phase, which guarantees that the results will be directly comparable. Monitoring investigations will be undertaken during the entire construction phase, and during three to five years of the operational phase.

Field investigations directly show wind-farm induced effects on fish, e.g. differences in species composition or abundance. Together with the results gained in the reference area, and further background information, such as fishing intensity or stock development of commercially exploited species, the overall effect of the wind farm on the local fish population can be ascertained.

In Germany, monitoring investigations are carried out and paid for by the applicants; hence these results are not open to the public. At present, the approval authority compiles all the collected data in order to optimise regional planning.

Monitoring investigations do not allow improvement of the applied technique as a result of the investigation, because the effects will only be visible after construction of the wind turbines. Furthermore, no discrimination of a singular triggering factor is possible. Several factors act simultaneously, but only their sum will be visible; hence the investigation of certain effects requires specific research (see Chapter 7).

### Sound and Vibration

**Fish hearing:** The data base on fish hearing is rather extensive. During the last fifty years, fish audiograms (frequency range, hearing thresholds) have been determined for various fish species. The measurement of fish audiograms is tedious. Uniform sound fields under water are difficult to obtain, and behavioural investigation require a long time for training. Often, invasive surgery is necessary. Fragile fish species cannot be

kept alive long enough to complete the required conditioning training and recording. Here, ABR technology offers many advantages. The available audiograms are generally of a lower quality than would be desirable. This is mainly due to the small number of measurements, the small number of individuals tested, and the lack of parallel measurements by different authors.

No conclusion on the behaviour or physiological state of the fish can be drawn from the audiogram. Behavioural effects have been observed in various experimental designs. Because of the high variation in dependency on the species, the sound level, the frequency range, and the kind of sound produced, a generalisation of the available findings can only give a rough estimation of the effect to be expected.

**Construction phase:** Measurements on the noise (frequency, sound level) emitted during piling are available for the construction of some wind farms and some other marine structures. The frequency range corresponds to the hearing range of many fish species. On sandy substrates, source levels were calculated in the range of 230 dB re 1  $\mu$ Pa. Hard rock substrates lead to high source levels of 260 dB re 1  $\mu$ Pa (peak-to-peak) - within the range in which some authors have detected injury to fish.

No specific investigations are known on the effects of noise emitted during pile driving for wind turbines on fish. Vibro-piling and impact-piling in a British harbour caused no discernible behavioural changes or injury in caged fish. Piling for a bridge in California caused injuries and mortalities in fish. Zones of direct and of delayed mortality have been defined. Sonar investigations revealed no escape behaviour by fish.

Overall, the risk of mortalities is considered low. Physiological effects are possible due to the piling noise of offshore wind farms. Various levels of injury could occur; primary and secondary stress responses are also potential reactions. The probability of behavioural reactions is estimated as the highest of all possible effects. Masking of intraspecific communication is possible in tonal species. The long term effects on a population basis cannot currently be predicted with any certainty.

**Operational phase:** Measurements on noise (frequency, sound level) emitted during the operational phase are available for relatively small turbines. Considerable variation occurs, depending on such factors as type and size of turbine, foundation, water depth, and sediment characteristics. The future wind farms are planned with eighty turbines of about 5 MW each. Presently, for larger offshore turbines, only extrapolations with considerable uncertainties exist, due, for one thing, to the variations dependant on the specific location.

The only direct investigation on the impact of wind farm induced sound on fish was made at a small offshore turbine (220 kW). During operation, the catchability of cod and roach decreased by a factor of two within 100 m of the windmill, compared to when the rotor was stopped. This might be interpreted as a displacement effect, but as no investigations of the variation in fish density were performed before construction, the difference may be attributed to other factors. No other investigations of the effects of long term continuous sound emissions on fish exist. Thus, predictions for the operational phase are prone to more uncertainties than for the construction period.

**Seismic surveys:** Airgun shots during seismic surveys for oil and gas deposits produce loud, short, impulse-like, low frequency signals. The sound levels emitted are typically on the order of 226 dB re 1  $\mu$ Pa at 1 m for a single airgun, or 248 dB re 1  $\mu$ Pa at 1 m for an array, with basic frequencies ranging from 0 Hz to 120 Hz. Because of the comparable sound levels and the impulsive nature of sound, parallels to piling noise are valid.

The observed effects on fish of seismic shooting range from physical injuries, mortalities, behavioural effects (flight and avoidance, C-starts, alarm response) and stress responses to severe reductions of catch rates. In spite of controversial discussions of the various investigations, there seems to be some agreement on the observation that seismic shooting can affect fish and reduce catch rates in an extended area around the noise source. These effects have been observed for cod, haddock and rockfish, whereas no effects have been observed for sandeels. Threshold values are identified by some authors. Serious injuries are expected for sound levels on the order of 220 dB re 1  $\mu$ Pa, whereas behavioural effects may be observed from about 160 dB re 1  $\mu$ Pa on.

There has been some effort to document the effects of seismic surveys on fish. Extensive studies have been performed in various regions with very great effort. However, the controversial scientific discussion of the results is an indicator of the complexity of the question. Also, the general problems of the documentation of the effects on a population base in an open system arise here once again.

### **Sediment disturbance**

The sensitivity of fish to **suspended sediment** depends on a variety of factors. Threshold values for increased mortality rates and reduced breeding success of various fish species have been presented. Roughly, the view is that concentrations of suspended sediment in the mg/l range will be lethal to eggs and larvae, and will provoke avoidance reactions by juvenile and adult fish, while concentrations in the range of g/l will be lethal to juveniles and adults. However, results vary greatly, depending on the species investigated, the design of the experiment, and the duration of exposure.

Suspended sediment may make pelagic fish eggs sink to the bottom. Demersal eggs may also be affected. Visual feeders will be affected, especially planktonic feeders. Planktonic larvae reacted with reduced growth rates up to mortalities. Behavioural reactions (avoidance and flight behaviour) were observed as a result of high sediment loads in the water column. The sediment type is important for the assessment of the impact intensity. Coarse particles may even lead to skin injuries. Especially fine sediments clog the gills and cause suffocation. Light absorption is highest in clay or coagulates of clay and organic material. Light limitation will affect the phyto-plankton and thus many organisms higher in the food web.

**Changes in sediment composition** affect those fish species that depend on certain bottom substrates for feeding, spawning, or breeding. Possible effects include a decrease in reproductive success, or food limitation for benthic feeders.

**Offshore wind farms:** Calculations on the amount of sediment plumes were performed on the basis of a computer simulation for various construction types for the wind farm at Rødsand, Denmark. Drilling and dredging work for a low gravitation foundation will cause sediment concentrations of more than 10 - 15 mg/l only in the direct vicinity of the digging area. These concentrations will only be exceeded in 10% of the construction period. Temporary effects on pelagic eggs and larvae are assumed in the immediate vicinity of the construction activity, together with potential, but smaller effect on demersal eggs and larvae. No lethal impact on juvenile or adult fish is expected, since flight or avoidance behaviour by them is predicted. It is assumed that high gravity foundations and monopile ramming will cause less disturbance to the fish fauna than lower gravity foundations. Drilling or washing a monopile causes major sediment plumes, but of a significantly shorter duration.

The Horns Rev wind farm in Denmark was investigated with respect to changes in sediment composition and abundance of sandeels, which have high demands on the sediment composition, as they spend long periods of their lives buried in the sand. Furthermore, the locally important sandeel fishery in areas around the wind farm demonstrates the high abundance of the species. The sediment composition was unchanged after the construction of the wind farm; no increase in the fine corn fraction was observed, nor was any decrease in sandeel abundance found.

**Sand and gravel extraction:** High sediment concentrations arise in the vicinity of dredging operations. Concentrations as high as 5000 mg/l were observed in the direct vicinity of the dredger. The formation of turbidity plumes depends on the natural turbidity of the water, the percentage of mud, and the prevailing hydrographical conditions. Usually, concentrations rapidly decrease with increasing distance from the source. Only the smaller fractions can be transported over longer distances. Lethal concentrations for fish eggs and larvae can occur in the direct vicinity of the dredging operations. Juvenile and adult fish will probably react by flight or avoidance. At greater distances from the dredging work, higher mortality rates of eggs or larvae of many fish species may occur. In the further surroundings, negative effects are to be expected only for the eggs or larvae of very sensitive species. Effects on the benthic fauna occur due to changes in sediment composition, so that benthic feeding fish are indirectly affected by a reduction of food supply. Conclusions by analogy have been drawn to assess the impact intensity.

Because of the higher sediment loads caused by the sand and gravel extraction, compared to foundation grounding for offshore wind farms, there is only a limited applicability of these results. Only areas further away from the sediment source (dredge) are characterised by identical sediment concentrations and therefore comparable to the situation of construction operations.

**Oil and gas exploitation:** Prior to the construction of the BalticPipe gas pipeline, tolerance thresholds for demersal fish were ascertained as  $> 10$  mg/l. Areas with sediment concentrations exceeding this threshold were determined by computer simulation. Short term effects on fish were predicted during the construction phase for fish species using the area as a spawning or breeding habitat. Effects on demersal fish eggs and larvae were considered possible, while no detectable effects on adult specimens were expected.

The effects of sediment change by oil platforms and bridge foundations on the benthic community were documented, along with changes of the grain size distribution. No specific investigations on the impact on fish were undertaken.

### **Introduction of hard substrates**

The construction of artificial reefs has a long tradition especially in tropical waters. Artificial reefs are highly attractive to fish. Therefore, significant increases in catch rates have been observed. The attraction of reef structures is attributed to the increased food supply, protection from predators, means of orientation, function as a spawning ground, and refuge from intensive fishery.

Fish populations on artificial reefs resemble communities on natural hard substrate. Migrating fish species constitute the bulk of fish biomass in the surroundings of artificial reefs. The degree of colonisation by fish is affected by the substrate, shape, size, and height of a reef. The attraction to fish increases with reef-size. The higher its complexity, the more effective an artificial reef is for fish. Reef height is only important at water depths of  $> 40$  m, and is more important to migrating pelagic species than to stationary

demersal species. For the latter, the horizontal spread of the reef is more important. Results on the impact range of artificial reefs for some fish species are given.

Most studies regarding the significance of artificial reefs focus on fishery-related economic issues. Nevertheless, some general conclusions can be drawn from these studies, by which derivations with regard to nature-conservationist aspects as well as non-commercial fish species are possible.

**Offshore wind farms:** Investigations at the Horns Rev wind farm state that the monopile structure will be of minor attraction to fish fauna, whereas the scour protection will form the basis for high biodiversity. Prior to construction, it was assumed that gadoid fish would be attracted by the vertical dimension of the foundation, whereas attraction to flatfish was predicted from the scour protection. The available monitoring investigations have confirmed this initial prognosis. Hydroacoustic recordings of fish abundance at Horns Rev found higher densities in connection with turbine foundations in one out of four transects. Fish were found to be attracted by the wind farm beyond a distance of 500 m.

Previous studies at the Nysted wind farm have been obviated due to a lack of data density.

Investigations have been undertaken on steel monopile foundations at Utgrunden and Yttre Stengrund in Sweden. The fish community close to the turbines was characterised by higher diversity and abundance than at a distance of 20 m.

Investigations at the test turbine Svante 1 in Sweden allowed no final statement on the existence of a reef effect of the turbine's steel tripod foundation, as no reference studies had been undertaken prior to its construction.

**Oil and gas exploitation:** Oil production installations (platforms, scour protections, pipelines) also act as artificial reefs. Attraction has been documented for the gadoid species cod, pollack, ling, and haddock. Highest fish densities have often been observed in the range of some hundreds of metres from platforms. Attraction is attributed to high prey density and the flow protection of the platform. Artificial reefs are more attractive to migrating species in relatively shallow homogeneous environments than in more heterogeneous regions. Steel structures with high complexity cause increased attractiveness over concrete foundations. The vertical profile of the platform has been shown to be of varying importance for different developmental stages of fish.

### **Electromagnetic fields**

Electric and magnetic fields are induced in the vicinity of underwater cables. Field strengths depend, among other things, on cable type and burial depth. Effects of electric fields on fish may occur in the form of disturbance of orientation, scaring reaction, redirection and torpidity. Threshold values for fish depend on species specific sensitivity and the size of the fish.

**Electric fields** are used by electro-sensitive fish for prey detection, spatial orientation, and probably navigation. The lowest thresholds for electric fields have been proved for elasmobranchs and lampreys. Behavioural responses were observed as reactions to changes in electric field strength.

**Magnetic fields** are used by fish for navigation during migrations. Elasmobranchs already perceive very weak magnetic fields. It is assumed that eels react to changes of magnetic field of the same order of magnitude as the earth's magnetic field. Definite reactions in eels, however, have only been proven for very high field strengths.



Laboratory experiments with glass eels did not reveal significant reactions to intense artificial magnetic fields. Tagging experiments with silver eels in the surrounding of a HVDC cable lead the authors to exclude the existence of a permanent barrier effect due to the cable.

**Offshore wind farms:** Avoidance behaviour as well as attraction was observed for the lesser spotted dogfish in a model test of the effects of electromagnetic fields. The attraction effect of the lower field strength is explained by the fact that this corresponds to the field strength that typical prey animals emit by their physical movements.

Simulations of the field strengths of typical sea cable have resulted in values in a range where elasmobranchs are attracted as well as scared. Even at a distance of 20 m from the cable, the electric field still overlaps with the sensitivity range of many elasmobranchs.

At the Svante wind farm in Sweden, no definite prove of change in eel behaviour was found due to the turbine. However, no movements of eels closer than 500 m from the turbine were registered, so that disturbance within <500 m cannot be excluded.

No significant differences were found between the pre-operational and the operational phases of the Nysted wind farm, Denmark, when the distribution of selected fish species was observed in relation to a cable of the power grid connection.

### **Cumulative Impacts**

The present review has documented similar or identical project induced impacts for different offshore utilisations (e.g. wind farms, oil and gas exploitation, sand and gravel dredging). Therefore, the existence of cumulative impacts is highly probable for some impact complexes. However, no investigations of the effects of cumulative exposure of fish to any type of sound are known. Nor have there been any investigations to determine the interaction between various impact complexes. Considering the weak data base of predicting the effects of a single wind farm, no assessment of cumulative effects based on sound scientific evidence can be given for most of the impact complexes.

A crucial point is the existence of threshold values for every impact complex. The present literature study has documented that there are some attempts to specify threshold values. Their general practicability, however, has not yet been proven.

Furthermore, a fundamental concept for the measurement of cumulative impacts is required. Since many wind farms are currently still in the planning phase, actual measurement is not feasible in most cases; only prognoses are available. The assessment of cumulative effects of several wind farms has to be based on the assessment of the impacts of every single wind farm. Therefore, the uncertainties included in the predictions are increased in the course of this process.

This conclusion stresses the importance of monitoring investigations, as they are the only way to reassess the predictions of the pre-construction phase. By adjusting and improving the initial assessments, it will be possible to place the resulting conclusions on a solid base.

For a thorough assessment of cumulative effects of the various forms of marine utilisations, it is recommended that a successive approach be carried out. In an initial step, the additive impact complexes should be dealt with. These include impacts with identical effects on the same subject of protection in such a way that the cumulative impact exceeds the sum of single impacts. Synergetic effects should not be considered until the assessment of additive impacts is well founded and reliable.

## 7 Conclusions

### Sound and vibration

Even though the quality of the existing fish audiograms is considered to be lower than would be desirable as a basis of a robust further algorithm, it is judged to be sufficient as a basis for the initial assessment of wind farm induced effects on fish.

The effects of anthropogenic induced sound on fish must be investigated in greater detail. On the basis of the prevailing results, it is not even possible to assess the trend of behavioural effects, as both attraction and startle or flight responses have been described. Specific research needs to deal with the local fish species and the specific sound emitted during the construction and operational phases. Special focus should be placed on the question of habituation. It has to be kept in mind that hardness of hearing might be mistaken for habituation, as in both cases fishes would not show reactions any longer.

Studies are required to investigate the effects of wind farm induced noise on fish. To some extent, these will have to be undertaken in experimental environments (tanks or quiet surroundings with artificially emitted noise) in order to separate the sound effect from other effects (e.g. the reef effect) which might counteract it.

Both measurements of noise (frequency, sound level) emitted during pile driving and measurements of operational noise exist. There is, however, a major knowledge gap involving operational noise emitted by large offshore turbines such as those to be used in the wind farms applied for or approved in the German EEZ.

In addition to the information on the operational noise of single wind turbines, the acoustic emissions of entire wind farms need to be investigated.

### Sediment disturbance

To a large extent, the effects of sediment plumes caused by various offshore activities have been assessed by means of computer models, resulting in information on sediment concentrations to be expected, which has been linked with the results of fundamental research on the effects on fish. The scientific data base for the impact assessment of sediments on various fish species is rather extended. However, no specific research on the effects of wind farm induced sediment plumes on fish has been performed at the various wind farm locations during the construction phase. Investigations are needed to evaluate the quality of the theoretical predictions.

The generalisation of threshold values to other locations or other species must be examined very carefully.

### Introduction of hard substrates

To date, investigations on the reef effect of offshore wind farms have been performed on monopile foundations. They have been able to demonstrate a reef effect to a certain extent. However, most actually planned offshore wind farms will be situated in water depths of up to 40 m, where preferably jacket or tripod foundations will be used. The available results cannot be generalised to other foundation types or significantly different water depths.

The investigations of Horns Rev can only be generalised to locations farther offshore to a limited extent. This is due to the near-shore location and the prevailing shallow waters. Furthermore, for many other locations, sandeels, the major species under investigation, are of much less importance than at Horns Rev.

On the other hand, a generalisation of results gained at oil platforms to wind turbine platforms could have greater justification. Because of the similar water depths and the comparable construction details (highly complex), parallels can be drawn between these two types of foundations. This especially holds true for tripod and jacket foundations. Nevertheless, this assumption must be evaluated further.

Based on the technological state of the art, most wind farms are planned with larger turbines than those investigated to date. Thus, greater intervals are required between turbines in order to maintain optimal wind conditions, so that their turbulences do not interfere with each other's wind fields. This must be kept in mind when the prevailing results are generalised to future wind farms.

Results from certain fish species support the view that the impact range of each wind turbine, acting as an artificial reef, is small enough that their sum will not arrive at a "wind farm-effect". However, results on some flatfish species make this interpretation borderline. More research is needed to answer the question of how the reef effect of a whole wind farm will be, compared to the effect of a single turbine.

### **Electromagnetic fields**

The data base concerning the electromagnetic fields of wind farm cables and their effects on the migration and behaviour of fish is still weak. This is true both of cable type and burying depth, and therefore for expected field strengths. Even though the general impacts of electric fields are well known, some variations exist in the magnitude of threshold values that have been determined in various investigations.

The highest sensitivities for electric fields were determined for elasmobranchs and lampreys. Nevertheless, no direct investigations were found concerning their reactions to electric cables. These investigations are of special importance, as it has been shown that the electric field strength of typical cables will be in a range where elasmobranchs are attracted as well as scared. Which reaction will be predominant must still be determined.

## 8 References

- ANDREWS, R.A.; HOWE, B.M. & MERCER, J.A. (2002): Ocean ambient noise: Comparing the 1960s with the 1990s for a receiver off the California coast. - *Acoustic Research Letters Online* 3(2): 65-70.
- AMBROSE, R.F. & SWARBRICK, S.L. (1989): Comparison of fish assemblages on artificial and natural reefs off the coast of Southern California. - *Bull. Mar. Sci.* Vol 44: 718-733.
- ANRAKU, K.; MATSUDA, M.; NAKAHARA, M.; SHIGESATO, N. & KAWAMURA, G. (1998): Sound learned by red sea bream conditioned to intermittent 300 Hz sound. - *Nippon Suisan Gakkaishi* 63: 934-938.
- ANTHANASSOPOULOS, J., DALTON, J.S. & FISCHER, A.P. (1999): Offshore oil platform decommissioning: a comparative study of strategies and the ecological, regulatory, political and economic issues involved in decommissioning planning. - University of California, Santa Barbara: 101 p.
- APPELBERG, M.; HOLQVIST, M.; LAGENFELT, I.; LETTEVALL, E.; SPARREVIK, E.; WAHLBERG, M. & WESTERBERG, H. (2005): Öresundförbindelsens inverkan på fisk och fiske - Underlagsrapport 1992-2005. Fiskeriverket, Göteborg.
- ASTRUP, J. & MØHL, B. (1993): Detection of intense ultrasound by the cod (*Gadus morhua*). - *Journal of experimental Biology* 182: 71-80.
- AULD, A.H. & SCHUBEL, J.R. (1978): Effects of suspended sediments on fish eggs and larvae: a laboratory assessment. - *Estuarine and Coastal Marine Science* 6: 153-164.
- BAINE, M. (2002): The North Sea rigs-to reefs debate. - *ICES Journal of Marine Science* 59: 277-280.
- BEASON, R.C. (1997): Mechanisms of vertebrate magnetoreception. - *Comments Theor. Biol.* 20 (5): 339-360.
- BERGE, J.A. (1979): The perception of weak electric A.C. currents by the European eel, *Anguilla anguilla*. - *Comp. Biochem. Physiol.* 62A: 915-919.
- BETKE, K.; SCHULTZ-VON GLAHN, M.; PETERSEN, A. & GABRIEL, A. (2003): Messungen der Unterwasser-Schallabstrahlung einer Offshore-Windenergieanlage. - [www.itap.de/daga03owea.pdf](http://www.itap.de/daga03owea.pdf), 2. p.
- BIRKLUND, J. & WIJSMAN, J.W.M. (2005): Aggregate Extraction: A review on the effect on ecological Funktions. - Prepared for: EC Fifth Framework Programme Project SANDPIT: 54 p.
- BLAXTER, J.H.S. & HOSS, D.E. (1981): Startle response in herring: the effect of sound stimulus frequency, size of fish and selective interference with the acoustico-lateralis system. - *J. Mar. Biol. Ass. UK* 61: 871-879.
- BLAXTER, J.H.S.; GRAY, J.A.B. & DENTON, E.J. (1981): Sound and startle responses in herring shoals. - *J. Mar. Biol. Ass. UK* 61: 851-869.
- BOEHLERT, G.W. & MORGAN, J.B. (1985): Turbidity enhances feeding abilities of larval Pacific herring (*Clupea harengus pallasii*). - *Hydrobiologica* 123: 161-170.
- BOHNSACK, J.A. (1989): Are high densities of fishes at artificial reefs a result of habitat limitation or behavioural preference? - *Bull. Mar. Sci.* 44: 631-645.
- BOHNSACK, J.A. & SUTHERLAND, D.L. (1985): Artificial reef research: a review with recommendations for future priorities. - *Bull. Mar. Sci.* 37 (1): 11-39.
- BOHNSACK, J.A. & TALBOT, F.H. (1980): Species-packing by reef fishes on Australian and Caribbean reef: an experimental approach. - *Bull. Mar. Sci.* 30: 710-723.
- BOHNSACK, J.A., JAHNSON, D.L. & AMBROSE, R.F. (1991): Ecology of artificial reef habitats and fishes. In: SEAMAN JR.W. & SPRAGUE, L.M. (eds): *Artificial reefs off southeastern Florida - U.S.A.* *Bull. Mar. Sci.* 55 (2-3), 796-823.
- BOHNSACK, J.A., HARPER, D.E., MCCLELLAN, D.B. & HULSBECK, M. (1994): Effects of reef size on colonization and assemblage structure of fishes at artificial reefs off southeastern Florida, USA. - *Bull. Mar. Sci.* 55 (2-3): 796-823.
- BONE, Q. & MARSHALL, N.B. (1985): *Biologie der Fische*. - Gustav Fischer Verlag, Stuttgart, New York, 236 p.
- BONE, Q., MARSHALL, N.B. & BLAXTER, J.H.S. (1995): *Biology of fish*. Second edition. Blackie Academic & Professional, London.
- BOYD, S.E., REES, H.L., VIVIAN, C.M.G. & LIMPENNY, D.S. (2003): Review of current state of knowledge of the impacts of marine aggregate extraction – a UK perspective. – European marine sand and grave – shaping the future, EMSAGG Conference, 20-21 Feb. 2003, Delft University, The Netherlands.
- BUERKLE, U. (1968): Relation of Pure Tone Thresholds to Background Noise Level in the Atlantic Cod (*Gadus morhua*). - *J. Fish. Res. Bd Can.* 25: 1155-1160.

- BUERKLE, U. (1969): Auditory Masking and the Critical Band in Atlantic Cod (*Gadus morhua*). - J. Fish. Res. Bd Can. 26: 1113-1119.
- BRANNON, E. L., QUINN, T.P., LUCCHETTI, G.L. & ROSS, B.D. (1981): Compass orientation of sockeye salmon fry from a complex river system. Canadian Journal of Zoology 59: 1548-1553.
- BRANOVER, G.G. & VASILYEV, A.S. (1971): A study of the behaviour of the eel in natural and artificial magnetic fields and an analysis of its reception mechanism. - J. Ichthyol. 11: 608-614.
- BRAWN, V. M. (1961). Sound production by the cod (*Gadus callarias*). - Behaviour 18: 239-255.
- BUERKLE, U. (1967): An audiogram of the Atlantic cod, *Gadu morhua* L. - J. Fish. Res. Bd. Can., 24: 2309-2319.
- BULLOCK, T.H. (1973): Seeing the World through a New Sense: Electroreception in Fish. - Am. Sci. 61: 316-325.
- CASPERS, B.C., LOBEL, P.S. & YAN, H.Y (2003): The hearing sensitivity of the little skate, *Raja erinacea*: A comparison of two methods. - Environmental Biology of Fishes 68: 371-379.
- CARR, M.H., FORRESTER, G.E. & MCGINNIS, M.V. (1999) Ecological consequences of alternative abandonment strategies for POCS offshore facilities and implications for policy development. - Coastal Marine institute Annual Report, 1999.
- CARR, M.H., MCGINNIS, M.V., FORRESTER, G.E., HARDING, J. & RAIMONDI, P.T. (2003): Consequences of Alternative Decommissioning Options to Reef Fisch Assemblages and Implications for Decommissioning Policy. - MMS OCS Study 2003-053. Coastal Research Centre, Marine Science Institute, University of California, Santa Barbara, California. MMS Cooperative Agreement Number 14-35-0001-30758: 104 p.
- CHANG, K., LEE, S.C. & SHAO, K.T. (1977): Evaluation of artificial reef efficiency based on the studies of model reef fish community installed in northern Taiwan. - Bull. Inst. Zool., Academia Sinic 16: 23-36.
- CHAPMAN, C.J. (1973): Field studies in hearing of teleost fish. - Helgol. wiss. Meeresunters. 24: 371-390.
- CHAPMAN, C.J. & HAWKINS, A.D. (1973): A field study of hearing in cod, *Gadus morhua*. - J. Comp. Physiol. 85: 147-167.
- CHAPMAN, C.J. & SAND, O. (1974): Field studies of hearing in two species of flatfish *Pleuronectes platessa* (L.) and *Limanda limanda* (L.) (Family Pleuronectidae). - Comp. Biochem. Physiol. 47A: 371-385.
- CHAPMAN, C. J.; JOHNSTONE, A. D. F.; DUNN, J. R. & CREASEY, D. J. (1974): Reaction of Fish to Sound Generated by Divers' Open-Circuit Underwater Breathing. - Mar. Biol. 27: 357-366.
- CHARBONNEL, E. (1990): Les peuplements ichtyologiques des recifs artificiels dans le department des alpes-maritimes. - Bull- Soc. Zool. Fr. 115 (1): 193-194.
- CHEW, G.L. & BROWN, G.E. (1989): Orientation of rainbow trout (*Salmo gairdneri*) in normal and null magnetic fields. - Can. J. Zool. 67: 641-643.
- CLARKE, D.G. & WILBER, D.H. (2000): Assessment of potential impacts of dredging operations due to sediment Resuspension. – DOER Technical Notes Collection (ERDC TN-DOER-E9): 11 p.
- CMACS (2003): A baseline assessment of electromagnetic fields generated by offshore wind farm cables. - COWRIE Report EMF – 01-2002 66. 71 p.
- COHEN, E., GROSSLEIN, M., SISENWINE, M. & STEIMLE, F. (1980): A comparison of energy flow on Georges Bank and in the North Sea. - ICES CM 1980/L:64: 13 p.
- COLLIER, D. (1997): Ship and platform noise, propeller noise. In: CROCKER, M.J. (ed): Encyclopedia of Acoustics. John Wiley & Sons, Inc., New York.
- CRIPPS, S.J. & AABEL, J.P. (1995): DPI – Fish survey using R.O.V. data. RF-Rogaland Research Report No. RF-95/301. Stavanger, Norway. 12 p.
- DAAN, N., BROMLEY, P. J., HISLOP, J. R. H. & NIELSEN, N. A. (1990): Ecology of North Sea fish. - Netherlands Journal of Sea Research 26 (2-4): 343-386.
- DAHLKE, CH. (2002): Genehmigungsverfahren von Offshore-Windenergieanlagen nach der Seeanlagenverordnung. - Natur und Recht 24 (8): 472-479.
- DANKERS, P.J.T. (2002): The behaviour of fines released due to dredging. A literature review. Delft University of Technology. Hydraulic Engineering Section, Faculty of Civil Engineering and Geosciences: 59 p.
- DAVIS, N., VANBLARICOM, G.R. & DAYTONO, K. (1982): Man-made structures on marine sediments effects on adjacent benthic communities. – Mar. Biol. 70: 295-304.

- DEGN, U. (2000): ØDEGAARD & DANNESKIOLD-SAMSOE A/S. Offshore Wind Turbines –VVM Underwater Noise Measurements, Analysis, and Predictions. Report no. 00.792 rev.1 to SEAS Distribution, Haslev: 29 p.
- DENA, DEUTSCHE ENERGIE-AGENTUR (2005): Energiewirtschaftliche Planung für die Netzintegration von Windenergie in Deutschland an Land und Offshore bis zum Jahr 2020. (DENA-Netzstudie) – [www.offshore-wind.de/show\\_article.cfm?id=4593&cid=1348&suchwort=NETZSTUDIE](http://www.offshore-wind.de/show_article.cfm?id=4593&cid=1348&suchwort=NETZSTUDIE), 342 p.
- DEWI, DEUTSCHES WINDENERGIE-INSTITUT (2004): Standardverfahren zur Ermittlung und Bewertung der Belastung der Meeresumwelt durch Schallimmissionen von Offshore-Windenergieanlagen. - Abschlussbericht zum Forschungsvorhaben 0327528A an das BMU: 123 p.
- DHI (2000): Sedimentspredingsberegninger for havmøllerpark ved Rødsand. – Havmøllerpark ved Rødsand VVM-redegørelse. Baggrundsrapport nr. 1: 1-15.
- DIJKGRAAF, S. (1952): Über die Schallwahrnehmung bei Meeresfischen. - Z. vergl. Physiol. 34: 104-122.
- DOLMER, P., DAHL, K., FREDRIKSEN, S., BERGGREN, U., PRÜSSING, S., STØTTRUP, J.G. & LUNDGREN, B. (2002): Udvalget om Miljøpåvirkninger of fiskeriressourcer. Delrapport vedr. Habitatpåvirkninger. - DFU-rapport nr. 112-02: 53 p.
- DONG Naturgas A/S (2001a): BalticPipe Offshore Pipeline Environmental Impact Assessment, October 2001. 184 p.
- DONG Naturgas A/S (2001b): Sediment Spill and Sediment Spreading at Rødvig, Avedøre Holme East and Avedøre Holm South. Appendix K to BalticPipe Offshore Pipeline Environmental Impact Assessment, October 2001. 30 p.
- DOUBEN, K. (1989): De invloeden van baggerwerkzaamheden op het aquatisch milieu. Literaturstudie omtrent het baggprobleem in het Eems-Dollart estuarium en de Waddenzee. – Tech. rept. Waddenvereniging, Groningen.
- DUNNING, D.J.; ROSS, Q.E.; GEOGHEGAN, P.; REICHLER, J.J.; MENEZES, J.K. & WATSON, J.K. (1992): Alewives avoid high-frequency sound. - N. Am. J. Fish. Manage. 12: 407-416
- EHRICH, S. (2003): Auswirkungen von Offshore-Windkraftanlagen auf die Fischfauna. - NNA Berichte 16: 19-22.
- ENERGIE E2 A/S (2002): Annual Status Report Nysted Offshore Wind Farm – Environmental Monitoring Program 2002: 23 p.
- ENGÅS, A., MISUND, O.A., SOLDAL, A.V., HORVEI, B. UND SOLSTADS, A. (1995): Reactions of penned herring and cod to playback of original, frequency-filtered and time-smoothed vessel sound. - Fisheries Research 22, 243-254.
- ENGÅS, A.; LØKKEBORG, S.; ONA, E. & SOLDAL, A.V. (1996): Effects of seismic shooting on local abundance and catch rates of cod (*Gadus morhua*) and haddock (*Melanogrammus aeglefinus*). - Can. J. Fish. Aquat. Sci. 53: 2238-2249.
- ENGEL-SØRENSEN, K. & SKYT, P.H. (2001): Evaluation of the Effect of Sediment Spill from Offshore Wind Farm Construction on Marine Fish. – Report to SEAS, Denmark: 18 p.
- ENGEL-SØRENSEN, K. & SKYT, P.H. (2002): Evaluation of the Effect of Noise from Offshore Pile-Driving on Marine Fish. - Bio/consult as report to SEAS, Haslev, Dok. no. 1980-1-03-1-rev.2.UK: 23 p.
- ENGER, P.S. (1967): Hearing in Herring. - Comp. Biochem. Physiol., 22: 527-538.
- ENGER, P.S.; HAWKINS, A.D., SAND, O. & CHAPMAN, C.J. (1973): Directional sensitivity of saccular microphonic potentials in the haddock. - J. Exp. Biol. 59: 425-433.
- ENGER, P.S.; KALMIJN, A.D. & SAND, O. (1989): Behavioural investigations on the function of the lateral line and inner ear in predation. - In: COOMBS, S.; GÖRNER, P. & MÜNZ, H. (eds.): The mechanosensory lateral line. Springer-Verlag, New York: 375-387.
- ESSINK, K. (1999): Ecological effects of dumping of dredged sediments, options for management. – Journal of Coastal Conservation 5: 69-80.
- EVANS, P.G.H. (1998): Biology of cetaceans in the North-East Atlantic (in relation to seismic energy). In: TASKER, M.L. & WEIR, C. (eds.): Proceedings of the Seismic and Marine Mammals Workshop, London, Sea Mammal Research Unit, U. of St. Andrews, Scotland.
- EVERHART, W.H. & DUCHROW, R.M. (1970): Effects of suspended sediment on aquatic environments. - NTIS U.S. Department of Commerce, PB-196-641.
- FAGER, E., W. (1971): Pattern in the development of a marine community. - Limnol. Oceanogr. 16: 241-253.
- FAY, R.R. (1998): Auditory stream segregation in goldfish (*Carassius auratus*). - Her. Res. 120: 69-76.

- FAY, R.R. & POPPER, A.N. (eds.) (1998): Comparative Hearing: Fish and Amphibians. - Springer Handbook of Auditory Research. Springer Verlag, New York, Berlin, Heidelberg: 438 p.
- FOCK, H., JOHNNASSEN, P., KULLNICK, U., MARHOLD, S. & GREVE, W. (1999): Schwimmverhalten von Jungaalen in einem experimentell geänderten geomagnetischen Feld. Untersuchungen im Auftrag der HEW Hamburg. Forschungsinstitut Senkenberg, IMST, Univ. Duisburg, unpubl.: 33 p.
- FRICKE, R. (2000): Auswirkungen elektrischer und magnetischer Felder auf Meeresfische in der Nord und Ostsee. . – In: MERCK, T. & NORDHEIM, H.V. (eds.): Technische Eingriffe in marine Lebensräume. Workshop des Bundesamtes für Naturschutz- INA Vilm 27.-29. Oktober 1999. – BfN Skripten 29: 41-61.
- GALLAWAY, B.J. & LEWBEL, G.L. (1982): The ecology of petroleum platforms in the northwestern Gulf of Mexico: a community profile. - USFWS, Office of Biological Services, Washington, D.C. FWS/OBS-82/27. Bureau of Land Management, Gulf of Mexico OCS Regional Office, Open File Rep. 82-03: 92 p.
- GARCIA, C.B. (1991): Comparison of successional patterns on hard substrata: the Caribbean Sea and the North Sea. – (Universität Bremen – Dissertation): 145 p.
- GAUSLAND, I. (2003): Seismic Surveys Impact on Fish and Fisheries. - Report to Norwegian Oil Industry Association (OLF), Stavanger, March 2003: 41 p.
- GILL, A.B. & TAYLOR, H. (2001): The potential effects of electromagnetic fields generated by cabling between offshore wind turbines upon elasmobranch fishes. - Research Project for Countryside Council for Wales: 73 p.
- GOULD, J.L. (1984): Magnetic field sensitivity in animals. - Ann. Rev. Physiol. 46: 585-598.
- GREGG, K.L. (1995): Comparison of three manufactured artificial reef units in Onslow Bay, North Carolina. - N. Am. J. Fish. Manag. 15: 316-324.
- GREGORY, J. & CLABBURN, P. (2003): Avoidance behaviour of *Alosa fallax fallax* to pulsed ultrasound and its potential as a technique for monitoring clupeid spawning migration in a shallow river. - Aquatic Living Resources 16: 313-316.
- GROENEWOLD, S. & DANKERS, N.M.J.A. (2002): Exoslib, de ecologische rol van slib. – Tech rept. 519. Alterra, Wageningen.
- GROOT, S.J. DE (1979): The Potential Environmental Impact on Marine Gravel dredging in the North Sea. – Ocean Management 5: 233-249.
- GROOT, S.J. de (1980): The consequences of marine gravel dredging of spawning of herring, *Clupea harengus*. – Journal of Fish Biology 16: 605-611.
- GROSSMAN, G.D., JONES, G.P. & SEAMAN, W.J., JR. (1997): Do artificial reefs increase regional fish production? A review of existing data. - Fish Manag. 22: 17-23.
- GROVE, R.S. & SONU, C.J. (1983): Review of Japanese fishing reef technology. - Tech. Rep. 83-RD-137.
- GROVE, R., YUNGE, J. & SONU, C. (1983): Artificial Reef Technology: a Strategy for Active Impact Mitigation. - OCEANS 15: pp: 951- 956.
- GROVE, R.S.; SONU, C.H. & NAKAMURA, M. (1989): Recent Japanese trends in fishing reef design and planning. - Bull. Mar. Sci. 44: 984-996.
- GUBBAY, S. (2003): Marine aggregate extraction and biodiversity. Information, issues and gaps in understanding. - Report to the Joint Marine Programme of The Wildlife Trusts and WWF-UK. 20 p.
- HANSSON, S. (1995): En litteraturgenomgång av effekter på fisk av muddring och tipping, samt erfarenheter från ett provfiske inför Stålverk 80. - Tema Nord 513: 73-84.
- HASSEL, A.; KNUTSEN, T.; DALEN, J.; SKAAR, K.; LØKKEBORG, S.; MISUND, O.A.; ØSTENSEN, Ø.; FONN, M. & HAUGLAND, E.K. (2004): Influence of seismic shooting on the lesser sandeel (*Ammodytes marinus*). - ICES J. Mar. Sci. 61: 1165-1173.
- HASTINGS, M.; POPPER, A.N.; FINNERAN, J.J. & LANFORD, P.J. (1996): Effects of underwater sound on hair cells of the inner ear and lateral line in the oscar (*Astronotus ocellatus*). J. Acoust. Soc. Am. 99: 2576-2603.
- HAWKINS, A.D. (1973): The sensitivity of fish to sound. - Oceanograph. Mar. Biol. Ann. Rev. 111: 291-340.
- HAWKINS, A.D. & JOHNSTONE, A.D.F. (1978): The hearing of the Atlantic salmon, *Salmo salar*. - J. Fish Biol. 13: 655-673.
- HAWKINS, A.D. & RASMUSSEN, K.J. (1978): The calls of gadoid fish. - J. mar. biol. Ass. U.K. 58: 891-911.
- Hawkins, A.D. & Amorim, M.C.P. (2000): Spawning sounds of the male haddock, *Melanogrammus aeglefinus*. - Environ. Fish. Biol. 59 (1): 29-41.

- HENRIKSEN, O. (2002): Sound emissions of offshore windmills in operation. Handout zum Fachgespräch: Offshore-Windmills-sound emissions and marine mammals. - FTZ-Büsum, 15.01.2002.
- HERRMANN, C. & KRAUSE, J.C. (1998): Ökologische Auswirkungen der marinen Sand- und Kiesgewinnung. - In: Nordheim, H.v. & Boedeker, D. (eds.): Umweltvorsorge bei der marinen Sand- und Kiesgewinnung. – Tagungsband BLANO-Workshop INA Insel Vilm 18. Nov. 1998. – BfN-Skripten 23: 20-33.
- HEYER, G.W. et al. (1981): Field experiments on electrically evoked feedings responses in the pelagic blue shark, *Prionace glauca*. - Biol. Bull. 161 (2): 344-345.
- HITCHCOCK, D.R. & DRUCKER, B.R. (1996): Investigation of benthic and surface plumes associated with marine aggregates mining in United Kingdom. – In: The global – ocean operational oceanography Vol. 2. – Proceedings of the Oceanology International conference 1996: 221-234.
- HITCHCOCK, D.R., NEWELL, R.C. & SEIDERER, L.J. (2002): Integrated report on the impact of marine aggregate dredging on physical and biological resources of the sea bed. – US Department of the Interior, Minerals Management Service, International Activities and Marine Minerals Division (INTERMAR), Washington D.C. OCS Report Number 2000-054.
- HOFFMANN, E.; ASTRUP, J.; LARSEN, F. & MUNCH-PETERSEN, S. (2000): Effects of marine windfarms on the distribution of fish, shellfish and marine mammals in the Horns Rev area. - Baggrundsrapport nr. 24 to ELSAMPROJEKT A/S: 42 p.
- HOLBROOK, S.J., AMBROSE, R.F., BOSTFORD, L., CARR, M.H., RAIMONDI, P.T. & TEGNER, M.J. (2000): Ecological Issues Related to Decommissioning of California's Offshore Production Platforms: 41 p.
- HUECKEL, G.J. & BUCKLEY, R.M. (1987): The influence of prey communities on fish species assemblages on artificial reefs in Puget Sound Washington USA. - Environ. Biol. Fishes 19: 195-214.
- HVIDT, C., BECH, M., KLAUSTRUP, M. (2004): Monitoring programme – status Report 2003. Fish at the cabletrace. Nysted offshore wind farm at Rødsand: 68 p.
- HVIDT, C., BRÜNNER, L. & KNUDSEN, F.R. (2005): Hydroacoustic Monitoring of Fish Communities in Offshore Wind Farms. - Annual report 2004. Horns Rev Offshore Wind Farm. 21 p.
- HYGUM, B. (1993): Miljøpåverknings ved ral- og sandsugning. Et litteraturstudie om de biologiske effekter af råstofindvinding i havet. - Danmarks Miljøundersøgelser. - DMU- rapport nr. 81: 68 p.
- ICES (1992): Effects of extraction of marine sediments on fisheries. – ICES Cooperative Research Report 182.
- ICES (2001): Effects of extraction of Marine Sediments on the Marine Ecosystem - Report of the Working Group on the Effects of Extraction of Marine Sediments on the Marine Ecosystem. – ICES Coop.Res.Rep.No. 247: 80 p.
- ICES (2003): Working Group on the Effects of Extraction of Marine Sediments on the Marine Ecosystem. – ICES CM 2003/E:07.
- ICES (1998): ICES WGEXT Co-operative Research Report, Final Draft, April 24.
- ICES AGISC (2005): ICES Advisory Committee on Ecosystems (AGISC): Report of the Ad-hoc Group on the impacts of Sonar on Cetaceans and Fish (AGISC) (2<sup>nd</sup> edition). - ICES CM 2005/ACE, 57 p.
- JANKOWSKI, J.A. & ZIELKE, W. (1996): Data Support for the Deep-Sea Mining Impact Modelling. Institut für Strömungsmechanik und Elektronisches Rechnen im Bauwesen der Universität Hannover. 50 pp.
- JENSEN, H. (2001): Settlement dynamics in the lesser sandeel (*Ammodytes marinus*) in the North Sea. – University of Aberdeen – Dissertation.
- JENSEN, H., KRISTENSEN, P.S. & HOFFMANN, E. (2003): Sandeels and clams (*Spisula* sp.) in the wind turbine park at horns Reef. - Preliminary report to TechWise April 2003: 45 pp.
- JENSEN, H., KRISTENSEN, P.S. & HOFFMANN, E. (2004): Sandeels and clams (*Spisula* sp.) in the wind turbine park at horns Reef. – Final report to TechWise August 2004: 26 p.
- Johnston, D.W. & WILDISH, D.J. (1981): Avoidance of dredge spoil by herring (*Clupea harengus*). – Bull. of Environmental Contamination and Toxicology 26: 307-314.
- JOHNSTON, D.W. & WILDISH, D.J. (1982): Effects of suspended sediment on feeding by larval herring (*Clupea harengus*). - Bull. of Environmental Contamination and Toxicology 29: 261-267.
- JOHNSTON, S.A. JR. (1981): Estuarine dredge and fill activities: A review of impacts. - Environmental Management 5 (5): 427-440.
- JONES, R. (1984): Some observations on energy transfer through the North Sea and Georges Bank food webs. - Rapports et Procès-Verbaux des Réunions - Conseil International pour l'Exploration de la Mer 183: 204–217.



- JØRGENSEN, T., LØKKEBORG, S. & SOLDAL, A.V. (2002): Residence of fish in the vicinity of a decommissioned oil platform in the North Sea. *ICES Journal of Marine Science* 59: 288-293.
- KAFEMANN, R., LÜDEMANN, K., KELLER, O. BUCHER, C., FLECK, M. EBERLE, S. (2003): Umweltverträglichkeitsstudie zum Bau der Pilotphase des Offshore Windparks GlobalTech I (unveröffentlicht) - Gutachten im Auftrag der Nordsee Windpower GmbH & Co. KG: 387 p.
- KALMIJN, A.J. & KALMIJN, V. (1981): Orientation to uniform electric fields in the stringray, *Urolophus halleri*, sensitivity of response. - *Biol. Bull.* 161 (2): 347 p.
- KALMIJN, A.J. (1966): Electro-perception in sharks and rays. - *Nature* 212: 1232-1233.
- KALMIJN, A.J. (1977): The electric and magnetic sense of sharks, skates and rays. - *Oceanus* 20 (3): 45-52.
- KALMIJN, A.J. (1982): Electric and magnetic field detection in elasmobranch fishes.- *Science* 218 (4575): 916-918.
- KALMIJN, A.J. (1984): Theory of electromagnetic orientation: a further analysis. In: BOLIS, L., KEYNES, R.D. (eds.): *Comparative physiology of sensory systems*. - Cambridge University Press: 525 - 560.
- KALMIJN, A.J. (1988): Detection of weak electric fields. In: ATEMA, J. (ed.): *Sensory biology of aquatic vertebrates – International Conference on the Sensory Biology of Aquatic Animals 1985*, Sarasota, Fla.: 151-186.
- KARLSEN, H.E. (1992): Infrasonic sensitivity in the plaice (*Pleuronectes platessa*). - *J. exp. Biol.* 171: 173-187.
- KENCHINGTON, T. (1999): Impacts of Seismic Surveys on Fish Behaviour and Fisheries Catch Rates on Georges Bank. - Report to NORGIS 2000, for submission to the Georges Bank Review Panel, Halifax, Nova Scotia, 21 p.
- KENYON, T.N., LADICH, F. & YAN, H.Y. (1998): A comparative study of hearing ability in fishes: the auditory brainstem response approach. - *J. Comp. Physiol.* 182: 307-318.
- KENNY, A.J. & REES, H.L. (1996): The Effects of Marine Gravel dredging on the Macrobenthos: Results 2 Years Post Dredging. – *Mar. Poll. Bull.* 32 (8/9): 615-622.
- KIM, C.G., JEONG, W.L. & PARK, J.S. (1994): Artificial reef design for Korean coastal waters. -*Bull. Mar. Sci.* 55 (2): 858-866.
- KIØRBOE & MOHLENBERG (1981): Particle Selection in Suspension-Feeding Bivalves. – *Mar. Ecol. Prog. Ser.* 5: 291-296.
- KIØRBOE, T., FRANTSEN, E., JENSEN, C. & NOHR, O. (1981): Effects of suspended sediment on development and hatching of herring (*Clupea harengus*) eggs. - *Estuarine and Coastal Shelf Science* 13: 107-111.
- KNOTT, D. (1995): North Sea operators tackling platform abandonment problems. - *Oil and Gas Journal* 93 (12).
- KNUDSEN, F.R.; ENGER, P.S. & SAND, O. (1992): Awareness reactions and avoidance responses to sound in juvenile Atlantic salmon, *Salmo salar* L. - *J. Fish Biol.* 40: 523-534.
- KNUDSEN, F.R., ENGER, P.S. & SAND, O. (1994): Avoidance responses to low frequency sound in downstream migrating Atlantic salmon smolt, *Salmo salar*. - *J. Fish Biol.* 45(2): 227-233
- KNUDSEN, F.R.; SCHRECK, C.B.; KNAPP, S.M.; ENGER, P.S. & SAND, O. (1997): Infrasonic produces flight and avoidance responses in Pacific juvenile salmonids. *Journal of Fish Biology* 51 (4): 824 - 829.
- KNUDTSON, B.K. & STIMERS, J.R. (1977): Notes on the behaviour of elasmobranch fishes exposed to magnetic fields. - *Bull. South California Acad. Sci.* 76 (3): 202-204.
- KNUST, R.; DALHOFF, P.; GABRIEL, J.; HEUERS, J.; HÜPPOP, O. & WENDELN, H. (2003): Untersuchungen zur Vermeidung und Verminderung von Belastungen der Meeresumwelt durch Offshore-Windenergieanlagen im küstenfernen Bereich der Nord- und Ostsee – Offshore-WEA. In: BUNDESMINISTERIUM FÜR UMWELT, NATURSCHUTZ UND REAKTORSICHERHEIT (BMU) [ed.] (2003): Abschlussbericht zum F & E Vorhaben 200 97 106: 453 p.
- KOSCHINSKY, S. (2004): Schallbelastung für Meeressäugetiere durch die Kiesgewinnung. - Hintergrundpapier für die Gesellschaft zum Schutz der Meeressäugetiere e.V., Quickborn, 2 p.
- KRAUSE, J.C., NORDHEIM, H.V. & GOSELCK, F. (1996): Auswirkungen submariner Kiesgewinnung auf die benthische Makrofauna in der Ostsee vor Mecklenburg-Vorpommern. – *Deutsche Zeitschrift für Hydrography, Supplement* 6: 189-199.
- KROG, C. (1999): Vrag og revfiskeri i Kattegat. In: STØTTRUP, J.G. (ed.): Kortlægning af stenrev, stenfiskeri og fiskeri på hårbund samt metoder til videnskabelige undersøgelser af rev og hårbund. - DFU-report nr. 63-99.

- KULLNICK, U. & MARHOLD, S. (2000): Direkte oder indirekte biologische Wirkungen durch magnetische und/oder elektrische Felder im marinen (aquatischen) Lebensraum: Überblick über den derzeitigen Erkenntnisstand. Teil I. – In: MERCK, T. & NORDHEIM, H.v. (eds.): Technische Eingriffe in marine Lebensräume. BfN Workshop des Bundesamtes für Naturschutz- INA Vilm 27-29 October 1999. – BfN Skripten 29: 4-18.
- KUWATANI, Y. (1982): On the fish-gathering mechanisms of reefs. In: VIK, S.F. (ed.): Japanese artificial reef technology. – Aquabio, Inc., 2957 Sunset Blvd., Bellair Bluffs, L. -Tech. Rep. 604: 260-268.
- LARSEN (1985): Workshop on Effects of Explosives Use in the Marine Environment, Halifax, 1985.
- LARSSON, M. (1992): Fiskspärrar. Metoder att leda (skrämma, locka) fisk i anslutning till vattenkraftsanläggningar. – Vattenfall Rapport H 1992/5.
- LEE, C.H.; MOON, J.W.; PARK, Y.S.; CHOI, C.M. & SEO, D.O. (1998): Behavior response of the shoal of anchovy *Engraulis japonica* to audible underwater sound. – Bull. Mar. Res. Inst., Cheju National University. Cheju 22: 113-119.
- LEEWIS, R. & HALLIE, F. (2000): An artificial reef experiment off the Dutch Coast. In: JENSEN, A.C., COLLINS, K.J. & LOCKWOOD, A.P.M. (eds.) Artificial Reefs in European Seas. Dordrecht, The Netherlands, Kluwer Academic Publishers: 289-305.
- LEONHARD, S.B. (2000): Horns Rev Offshore Wind Farm – Environmental Impact Assessment of Sea Bottom and Marine Biology. – Report to ELSAMPROJEKT A/S. Baggrundsrapport 19: 43p.
- LEONHARD, S.B. (2005): Impacts of offshore wind farms on benthos and fish communities experiences from the Danish offshore wind farms. Abstract of the Presentation during: The International Exchange of Experiences on the Assessment of the Ecological Impacts of Offshore Wind Farms March 17.-18. 2005 at the Berlin University of Technology.
- LEONHARD, S.B. & PEDERSEN, J. (2004): Hard Bottom Substrate Monitoring Horns Rev Offshore Wind Farm. – Annual Status Report 2003 to ELSAM Engineering. 62 p.
- LINDELL, H. (2003): Utgrunden off-shore wind farm - Measurements of underwater noise. – Ingemansson Technology AB, Report 11-00329-03012700 for Airicole, GE Wind Energy, SEAS/Energij/E2, 30 p.
- LOHMANN, K.J. & JOHNSEN, S. (2000): The neurobiology of magneto reception in vertebrate animals TINS 23 (4): 153-159.
- LØKKEBORG, S. & SOLDAL, A.V. (1993): The influence of seismic exploration with air guns on cod (*Gadus morhua*) behaviour and catch rates. – ICES Mar. Sci. Symp. 196: 62-67.
- LØKKEBORG, S., HUMBORSTAD, O.-B., JØRGENSEN, T. & SOLDAL, A.V. (2002): Spatio-temporal variations in gillnet catch rates in the vicinity of North Sea oil platforms. – ICES Journal of Marine Science 59: 294-299.
- LOVE, M.S., CASELLE, J.E. & SNOOK, L. (2000): Fish assemblages around seven oil platforms in the Santa Barbara Channel area. – Fish Bull. 98: 96-117.
- LUGLI, M., YAN, H.Y. & FINE, M.L. (2003): Acoustic communication in two freshwater gobies: the relationship between ambient noise, hearing threshold and sound spectrum. – J. Comp. Physiol. 189: 309-320.
- MACER, C.T. (1966): Sandeels (Ammodytidae) in the south-western North Sea; their biology and fishery. – Fish. Invest. Lond. Ser. 2 (24): 1-55.
- MALM, T. (2005): Wind power plants in the sea - A method to locally increase the biodiversity in the Baltic Sea? – Report to the National Energy Agency, Wind research programm. Stockholm University, Department of Botany, section for plant ecology: 12 p.
- MANN, D.A.; HIGGS, D.M.; TAVOLGA, W.N.; SOUZA, M.J. & POPPER, A.N. (2001): Ultrasound detection by clupeiform fishes. – J. Acoust. Soc. Am. 109 (6): 3048-3054.
- MANN, D.A.; ZHONGMIN, L.; HASTINGS, M.C. & POPPER, A.N. (1998): Detection of ultrasonic tones and simulated dolphin echolocation clicks by a teleost fish, the American shad (*Alosa sapidissima*). – J. Acoust. Soc. Am. 104 (1): 562-568.
- MARHOLD, S. & KULLNICK, U. (2000): Direkte oder indirekte biologische Wirkungen durch magnetische und/oder elektrische Felder im marinen (aquatischen) Lebensraum: Überblick über den derzeitigen Erkenntnisstand. Teil II: Orientierung, Navigation Migration. – In: MERCK, T. & NORDHEIM, H.v. (eds.): Technische Eingriffe in marine Lebensräume. Workshop des Bundesamtes für Naturschutz- INA Vilm 27-29 October 1999. – BfN Skripten 29: 4-18.
- MARINO, A.A. & BECKER, R.O. (1977): Biological effects of extremely low frequency electric and magnetic fields: a review. – Physiol. Chem. Phys. 9 (2): 131-148.

- MCCAULEY, R.D. (1994): Seismic Surveys. In: SWAN, J.M.; NEFF, J.M. & YOUNG, P.C. (HRSG.): Environmental implications of offshore oil and gas development in Australia – the findings of an independent scientific review. APEA, Sydney: 19-121.
- MCCAULY, R.D.; FEWTRELL, J.; DUNCAN, A.J.; JENNER, C.; JENNER, M.-N.; PENROSE, J.D., PRINCE, R.I.T.; ADHITYA, A.; MURDOCH, J. & MCCABE, K. (2000): Marine seismic surveys - a study of environmental implications. - APPEA-Journal 2000: 692-707.
- MCCAULY, R.D.; FEWTRELL, J. & POPPER, A.N. (2003): High intensity anthropogenic sound damages fish ears. - J. Acoust. Soc. Am. 113 (1): 638-641.
- MCCLEAVE, J.D. & POWER, J.H. (1978): Influence of weak electric and magnetic fields on turning behavior in elvers of the American eel *Anguilla rostrata*. - Mar. Biol. 46: 29- 34.
- MCCLEAVE, J.D., ROMMEL, S.A. JR. & CATHCART, C.L. (1971): Weak electric and magnetic fields in fish orientation. Annals N.Y. - Acad. Sci. 188: 270-282.
- MCKANZIE MAXON, C. (2000): Offshore wind turbine construction. Offshore Pile Driving Underwater and Above water Noise measurements and analysis. - ØDGAARD & DANNESKIÖLD-SAMSØ A/S, Report no. 00.807 to SEAS Distribution A.m.b.A., Haslev and Enron Wind GmbH, Salzbergen: 31 p.
- MESSIEH, S.N., WILDISH, S.N. & PETERSON, R.H. (1981): Possible impact of sediment from dredging and spil disposal on the Miramichi Bay herring fishery. – Can. Tech Rep. Fish. and Aquat. Sci. 1008: 1-37.
- MITSON, R.B. (1995): Underwater noise of research vessels. - Cooperative Research report, no. 209, International Council for the Exploration of the Sea, Copenhagen, Danmark, 61 p.
- MOORE, P.G. (1991): Inorganic particulate suspensions in the sea and their effects on marine animals. - Oceanogr. Mar. Biol. Ann. Rev. 15: 335-363.
- MOTTET, M.G. (1981): Enhancement of the marine environment for fisheries and aquaculture in Japan. - Washington Dept. Fish. - Tech. Rep. 69.
- MYRBERG, A. A.; JR., SAMUEL, J.H.A.; WALEWSKI, S. & BANBURY, J.C. (1972): Effectiveness of acoustic signals in attracting epipelagic sharks to an underwater sound source. - Bull. Mar. Sci. 22: 926-949.
- NEDWELL, J. & HOWELL, D. (2004): A review of offshore windfarm related underwater noise sources. - Subacoustech report No. 544 R 0308, submitted to The Crown Estate Office (COWRIE): 55 p.
- NEDWELL, J.R.; TURNPENNY, A.W.H. & LAMBERT, D. (1998): Guiding fish with sound, the acoustics of fish behavioural barrier design. - 128<sup>th</sup> Annual Meeting of the American Fisheries Society Conference, Baltimore, USA, August 1998.
- NEDWELL, J.; LANGWORTHY, J. & HOWELL, D. (2003): Assessment of sub-sea acoustic noise and vibration from offshore wind turbines and its impact on marine wildlife; initial measurements of underwater noise during construction of offshore windfarms, and comparison with background noise. - Subacoustech report No. 544 R 0424, submitted to The Crown Estate Office (COWRIE): 56 p
- NEDWELL, J.R.; EDWARDS, B.; TURNPENNY, A.W.H. & GORDON, J. (2004): Fish and marine mammal audiograms: a summary of available information. - Subacoustech report ref. 534R0214, submitted to Chevron Texaco Ltd.: 278 p.
- NELSON, R.S. (1985): Growth of the gray triggerfish, *Balistes capricius*, on exploratory oil drilling platforms and natural reef areas in the northwest Gulf of Mexico (Abstract). - Bull. Mar. Sci. 37: 399.
- NESTLER, J.M.; PLOSKEY, G.R.; PICKENS, J.; MENEZES, J. & SCHILT, C. (1992): Responses of blueback herring to high-frequency sound and implications. - N. Am. J. Fish. Manage. 12 (4): 667-683.
- NEWCOMBE, C.P. & MACDONALD, D.D. (1991): Effects of suspended sediments on aquatic ecosystems. – North American Journal of Fisheries Management 11: 72-82.
- NEWELL, R.C., SEIDERER, L.J. & HITCHCOCK, D.R. (1998): The impact of dredging works in costal waters: a review of the sensitivity to disturbance and subsequent recovery of biological resources on the seabed. – Oceanography and Marine Biology: an Annual Review 36: 127-178.
- NIELSEN, P.E. (1997): Sediment spill and sedimentation in connection with dredging and construction work in marine environments. – Report submitted to the ICES Working Group on the Effects of Marine Sediments on the Marine Ecosystem, Copenhagen.
- NORSKER, N.-H. (1997): Status af forskning i fiskeribiologi på kunstige rev. In: STØTTRUP, J.G. & STOKHOLM, H. (eds.): Kunstige rev. Review om formål, anvendelse og potnetiale i danske farvande. - DFU-rapport nr. 42a-97 Bilag B: 127 p.
- NØTTESTAD, L. (1998): Fiskeforekomster langs rørledninger i Nordsjøen. Havforskningsinstituttet i Bergen - [www.odin.dep.no/oed/norsk/html/rporter/05/](http://www.odin.dep.no/oed/norsk/html/rporter/05/): 36 p.

- O'CONNOR, J.M., NEUMANN, D.A. & SHERK, J.A. (1976): Lethal effects of suspended-sediment on estuarine fish. – Technical Paper No. 76-20, U.S. Army Engineer Coastal Engineering Research Centre, Fort Belvoir, VA.
- OFFUTT, G.C. (1974): Structures for the detection of acoustic stimuli in the Atlantic codfish, *Gadus morhua*. - JASA 56(2), 665-671.
- OGAWA, Y. (1982a): Jinko gyosho, tsukiiso, and marine organisms. In: VIK, S.F. (ed.): Japanese artificial reef technology. Aquabio, Inc., 2957 Sunset Blvd., Bellair Bluffs, L. -Tech. Rep. 604: 42-48.
- OGAWA, Y. (1982b): Basic theory. In: VIK, S.F. (ed.): Japanese artificial reef technology. Aquabio, Inc., 2957 Sunset Blvd., Bellair Bluffs, L. - Tech. Rep. 604: 99-137.
- OGAWA, Y., TAKEUCHI, S. & HATTORI, A. (1977): An estimate for the optimum size of artificial reef. - Bull. Jap. Soc. Fish. Oceanogr. 30: 39-45.
- OSPAR (1999): Effects of dredging of marine sand and gravel on marine ecosystems. – IMPACT 99/5/13-E.
- PAGE, H.M., DUGAN, J.E., DUGAN, D.S., RICHARDS, J.B. & HUBBARD, D.M. (1999): Effects of an offshore oil platform on the distribution and abundance of commercially important crab species. - Mar. Ecol. Prog. Ser. 185: 47-57.
- PEARCE, F. (1995): What to do with Derricks? (Oil drilling in the North Sea). - World Press Review 42 (9).
- PEARSON, W.H.; SKALSKI, J.R. & MALME, C.I. (1992): Effects of Sound from a Geophysical Survey Device on Behaviour of Captive Rockfish (*Sebastes* spp.). - Can. J. Aquat. Sci. 49: 1343-1356.
- PETERSSON, M. (2000): Vindkraft till havs – en litteraturstudie av påverkan på djur och växter. - Naturvårdsverket Rapport 5139: 55 p.
- PHUA, C., AKKER, S.VD, BARETTA, M. & DALFSEN, J.V. (2004): Ecological Effects of Sand Extraction in the North Sea.
- PICKEN, G.B. & MCINTYRE, A.D. (1989): Rigs to reefs in the North Sea. - Bull. Mar. Sci. 44: 782-788.
- PIIDP (PILE INSTALLATION DEMONSTRATION PROJECT) (2001): Fisheries Impact Assessment. - San Francisco - Oakland Bay Bridge East Span Seismic Safety Project. PIPD EA 012081, Caltrans Contract 04A0148, Task Order 205.10.90, PIPD 04-ALA-80-0.0/0.5: 57 p.
- PINTO, J.M., PEARSON, W.H. & ANDERSON, J.W. (1984): Sediment preferences and oil contamination in the Pacific sand lance (*Ammodytes hexapterus*). – Mar. Biol. 83: 193-204.
- POLÉO, A.B.S., JOHANNESSEN, H.F., HARBOE, M. JR. (2001): High voltage direct current (HVDC) sea cables and sea electrodes: Effects on marine life. – 1st revision of the literature study: 50 p.
- POLOVINA, J.J. & SAKI, I. (1989): Impacts of artificial reefs on fishery production in Shimamaki, Japan. - Bull. Mar. Sci. 44: 997-1003.
- POPPER, A.N. & CLARKE, N.L. (1976): The auditory system of the goldfish (*Carassius auratus*) : effects of intense acoustic stimulation. - J. Comp. Biochem. Physiol. 53A: 11-18.
- POPPER, A.; PLACHTA, D.T.T.; MANN, D.A. & HIGGS, D. (2004): Response of clupeid fish to ultrasound: a review. - ICES Journal of Marine Science 61: 1057-1061.
- POSFORD, DUVIVIER ENVIRONMENT & HILL, M.I. (2001): Guidelines on the impact of aggregate extraction on European Marine Sites. – Countryside Council for Wales (UK Marine SACs Project). 125 p.
- POWERS, S.P., GRABOWSKI, J.H., PETERSON, C.H. & LINDBERG, W.J. (2003): Estimating enhancement of fish production by offshore artificial reefs: uncertainty exhibited by divergent scenarios. - Mar. Ecol. Prog. Ser. 246: 265-277.
- QUINN, T.P. (1980): Evidence for celestial and magnetic compass orientation in lake migrating sockeye salmon fry. - J. Comp. Physiol. 137A: 243-248.
- QUINN, T.P. & BRANNON, E.L. (1982): The use of celestial and magnetic cues by orienting sockeye salmon smolts. - J. Comp. Physiol. 147: 547-552.
- QUINN, T.P. & GROOT, C. (1983): Orientation of chum salmon (*Oncorhynchus keta*) after internal and external magnetic field alteration. - Can. J. Fish. Aquat. Sci. 40: 1598-1606.
- RANDALL, J.E. (1963): An analysis of the fish populations of artificial and natural reefs in Virgin Islands. - Caribb. J. Sci. 3: 31-47.
- RELAY, P.J. (1970): Synopsis of biological data on North Atlantic Sandeels of the genus *Ammodytes*. – FAO Fisheries Synopsis 82.
- RELINI, G., TORCHIA, G. & RELINI (1994): Seasonal Variation of fish assemblages in the Loana Artificial Reef (Ligurian Sea Northwestern-Mediterranean). - Bull. Mar. Sci. 55 (2-3): 401-417.

- RICHARD J.D. (1968): Fish attraction with pulsed low-frequency sound. - J. Fish. Res. Bd Can. 25, 1441-1452
- RICHARDSON, W.J.; GREENE, C.R.G. JR.; MALME, C.I. & THOMSON, D.H. (1995): Marine Mammals and Noise. - Academic Press, San Diego: 576 p.
- ROMMEL, S.A., JR. & MCCLEAVE, J.D. (1973): Sensitivity of American eels (*Anguilla rostrata*) and Atlantic salmon (*Salmo salar*) to weak electric and magnetic fields. J. Fish. Res. Board Can. 30: 657-663.
- ROSS, Q.E., DUNNING, D.J., MENEZES, J.K., KENNA, M.J.JR. & TILLER, G. (1996): Reducing impingement of alewives with high-frequency sound at a power plant intake on Lake Ontario. - N. Am. J. Fish. Manage. 16(3): 548-559.
- ROSS, Q.E.; DUNNING, D.J.; THORNE, R.; MENEZES, J.K.; TILLER, G.W. & WATSON, J.K. (1993): Response of alewives to high-frequency sound at a power plant intake on Lake Ontario. - N. Am. J. Fish. Manage. 13: 291-303.
- ROZENMEIJER, M.J.C. (1999): Van ei tot kinderkammerbewoner. - RIKZ.
- SAND, O. (1984): Lateral line system. In: BOLIS, L.; KEYNES, R. & MADDRESS, S. (eds.): Comparative physiology of sensory systems. - Cambridge University Press, Cambridge: 3-32.
- SAND, O. & KARLSEN, H.E (1986): Detection of infrasound by the Atlantic cod. - J. exp. Biol. 125: 197-204.
- SAND, O.; ENGER, P.S.; KARLSEN, H.E.; KNUDSEN, F. & KVERNSTUEN, T. (2000): Avoidance responses to infrasound in downstream migrating European silver eels, *Anguilla anguilla*.- Environ. Biol. Fish. 57 (3): 327-336.
- SANTULLI, A.; MODICA, A.; MESSINA, C.; CEFFA, L.; CURATOLO, A.; RIVAS, G.; FABI, G. & D'AMELIO, V. (1999): Biochemical responses of European Sea Bass (*Dicentrarchus labrax* L.) to the stress induced by off shore experimental seismic prospecting. - Mar. Pollut. Bull. 38 (12): 1105-1114.
- SCHOLIK, A.R. & YAN, H.Y (2001): Effects of underwater noise on auditory sensitivity of a cyprinid fish. - Hear. Res. 152: 17-24.
- SCHOLIK, A.R. & YAN, H.Y. (2002a): The effects of noise on the auditory sensitivity of the bluegill sunfish, *Lepomis macrochirus*. - Comp. Biochem. Physiol. 133 Part A: 43-52.
- SCHOLIK, A.R. & YAN, H.Y. (2002b): Effects of boat engine noise on the auditory sensitivity of the fathead minnow, *Pimephales promelas*. - Environmental Biology of Fishes 63: 203-209.
- SCOTT, J.S. (1973): Food and inferred feeding behaviour of northern sand lance (*Ammodytes dubius*). - J. Fish. Res. Bd. Canada 30: 451-454.
- SEAMANN, W.S., JR. (2000): Artificial reef evaluation with application to natural marine habitats. - CRC Press, Boca Raton, FL.
- SILVA, M.W.R.N., DE (1989): Artificial Reefs. A practical means to enhance living marine resources. - In: CHUA, T.E. & PAULEY, D. (eds.): Coastal Area Management in SE Asia: Policies, Management Strategies and Case Studies. - ICLARM Conference proceedings 19: 173-180.
- SIMMONDS, M.; DOLMAN, S. & WEILGART, L. (eds.) (2004): Oceans of Noise - A WDCCS (Whale and Dolphin Conservatory Society) Science Report: 93 p.
- SISSEWINE, M. P., COHEN, E. B. & GROSSLEIN, M. D. (1984): Structure of the Georges Bank ecosystem. - Rapports et Procès-Verbaux des Réunions - Conseil International pour l'Exploration de la Mer 183: 243-254.
- SKALSKI, J.R.; PEARSON, W.H. & MALME, C.I. (1992): Effects of Sound from a Geophysical Survey Device on Catch-per-Unit-Effort in a Hook-and-Line Fishery for Rockfish (*Sebastes* spp.). - Can. J. Aquat. Sci. 49: 1357-1365.
- SMITH, M.E.; KANE, A.S. & POPPER, A.N. (2004): Noise-induced stress response and hearing loss in goldfish (*Carassius auratus*). - J. exp. Biol. 207: 427-435.
- SMITH, S. & WESTERBERG, H. (2003): Kunskapsläget vad gäller den havsbaserade vindkraftens effekter på fisket och fiskbestånden. Fiskeriverket Informerar (Finfo) 2003:2: 23 p.
- SODAL, A.V.; BRONSTAD, O.; HUMBORSTAD, O.; JORGENSEN, T.; LOKKEGOG, S. & SVELLINGEN, I. (1998): Oil production structures in the North Sea as fish aggregating devices. - ICES, CM 1998/U:11: 10 p.
- SOLDAL, A.V., SVELLINGEN, I., JØRGENSEN, T. & LØKKEBORG, S. (2002): Rigs-to-reef in the North Sea: hydroacoustic quantification of fish in the vicinity of a "semi-cold" platform. - ICES Journal of Marine Science 59: 281-287.
- SOUZA, J.J., POLUHOWICH, J.J. & GUERRA, R.J. (1988): Orientation responses of American eels, *Anguilla rostrata*, to varying magnetic fields. - J. Comp. Biochem. Physiol. 90A (1): 57-61.

- SPANIER, E., PISANTY, S. & A.-S. G. (1990): Artificial reefs in the low productive marine environment of the southeastern Mediterranean. - *Mar. Ecol. Vol. 11*: 61-75.
- SRU, DER RAT VON SACHVERSTÄNDIGEN FÜR UMWELTFRAGEN (2003): Windenergienutzung auf See-Stellungnahme: 20 p.
- STONE, R.B. (1978): Artificial reefs. - *Water Spectrum 10 (2)*: 24-29.
- STONE, R.B., PRATT, H.L., PARKER, R.O. JR. & DAVIS, G.E. (1979): A comparison of fish populations on an artificial and natural reef in the Florida Keys. - *Mar. Fish. Rev. 41 (9)*: 1-11.
- STØTTRUP, J.G. & STOKHOLM, H. (1997): Kunstige rev. Review om formål, anvendelse og potnetiale i danske farvande. - DFU-rapport nr. 42-97. 28 p.
- STRERNIN, V.G., NIKONOROV, I.V. & BUMESTER, Y.K. (1976): Electrical fishing: theory and practice.
- SVANNE, I. & PETERSEN, J.K. (1997): Om den økologisk forståelse af kunstige ref: et litteraturstudie af heterogenitet og dynamic. In: STØTTRUP, J.G. & STOKHOLM, H. (eds.): Kunstige rev. Review om formål, anvendelse og potnetiale i danske farvande. - DFU-rapport nr. 42a-97 Bilag A: 21 p.
- TAVOLGA, W.T. (1974): Signal/noise ratio and the critical band in fishes. - *J. Acoust. Soc. Am. 55(6)*: 1323-1333
- TAYLOR, P.B. (1986a): Experimental evidence for geomagnetic orientation in juvenile salmon, *Ochcorhynchus tshawytscha*. - *J. Fish Biol. 28*: 607-623.
- TAYLOR, P.B. (1986b): Experimental evidence of magnetic field exposure on fertilization success in rainbow trout, *Salmo gairdneri*. - *Bioelectromagnetics 4*: 295-301.
- TECH-WISE/ELSAM (2003): Elsam. Offshore-Windfarm Horns Rev. Annual status report for the environmental monitoring programm 1 January 2002 – 31 December 2002. Tech-Wise, Frederica, Denmark: 58 p.
- TESCH, F.W. & WENDT, T., (1992): Influence of geomagnetism on the activity and orientation of eel, *Anguilla anguilla*, as evident from laboratory experiment. - *Aq. Ecol. Freshw. Fish. 1*: 52– 60.
- THIELE, R. (2002): Propagation loss values for the North Sea. Handout re experts' consultation: Offshore windmills sound emissions and marine mammals. - FTZ-Büsum, 15 Jan. 2002.
- THIERRY, J.-M. (1988): Artificial reefs in Japan – A general outline. - *Aquacult. Engineering, 7*: 321-348.
- TODD, C.D., BENTLEY, M.C. & KINNEAR, J. (1992): Torness artificial reef project. – In: BAINE, M. (ed.): Artificial Reefs and Restocking. - Proceedings of a Conference, 12 September 1992, Stromness, Orkney Islands UK: 15-21.
- TURNER, C.H., EBERT, E.E. & GIVEN, R.R. (1969): Man-made reef ecology.- *Calif. Dept. Fish Game. - Fish. Bull. 146*: 221.
- TURNPENNY, A.W.H. & NEDWELL, J.R. (1994): Consultancy Report: The Effects on Marine Fish, Diving Mammals and Birds of Underwater Sound Generated by Seismic Surveys. - Fawley aquatic research Laboratories Ltd.: 40 p.
- URICK, R.J. (1983): Principles of underwater sound. (3. Ed.), McGraw-Hill, NewYork: 421 p.
- VALDEMARSEN, J.W. (1979): Behavioural aspects of fish in relation to oil platforms in the North Sea. - ICES, CM 1979/B:27: 11p.
- VARANELLI, C.C., & MCCLEAVE, J.D. (1974): Locomotor activity of Atlantic salmon parr (*Salmo salar L.*) in various light conditions and in weak magnetic fields. - *Anim. Behav. 22*: 178-186.
- VASILYEV, A.S. & GLEYZER, S.I. (1973): Changes in the activity of freshwater eel (*Anguilla anguilla*) in the magnetic fields. - *J. Ichtyol. 13*: 322-324.
- VELLA, G.; RUSHFORTH, I.; MASON, E.; HOUGH, A.; ENGLAND, R.; STYLES, P.; HOLT, T. & THORNE, P. (2001): Assessment of the effects of noise and vibration from Offshore Wind farms on marine wildlife. - Energy Technology Support Units (ETSU) report ETSU W/13/00566/REP, DTI/Pub URN 01/1341, 107 S.
- WAHLBERG, M. & WESTERBERG, H. (2005): Hearing in fish and their reactions to sound from offshore wind farms. - *Mar. Ecol. Prog. Ser. 288*: 295-309.
- WALKER, M.M., DIEBEL, C.E., HAUGH, C.V., PANKHURST, P.M., MONTGOMERY, J.C. & GREEN, C.R. (1997): Structure and function of the vertebrate magnetic sense. - *Nature 390*: 371–376.
- WARDLE, C.S. & CARTER, T.J. (1998): Effects of a triple "G" airgun on fish behaviour. - In: TASKER, M.L. & WEIR, C. (eds.): Proceedings of the Seismic and Marine Mammals Workshop, London, 23-25. June 1998
- WARDLE, C.S.; CARTER, T.J.; URQUHART, G.G.; JOHNSTONE, A.D.F.; ZIOLOKOWSKI, A.M.; HAMPSON, G. & MACKIE, D. (1998): Effects of a seismic air gun on marine fish. - *Cont. Shelf Res. 21*: 1005-1027.

- WATER CONSULT (1997): The Fixed Link across Øresund: Spill monitoring at reclamation of sand at Kriegers Flak for use at the Fixed Link across Øresund. – Report on behalf of the Øresundkonsortiet.
- WENZ, G. (1962): Acoustic ambient noise in the ocean: spectra and sources. - J- Acoust. Soc. Am 34: 1936-1956.
- WESTERBERG, H. (1993): Öresundkonsortiet, miljökonsekvensbeskrivning för Öresundförbindelsen. Effekter på ljus och vibrationer på fiskvandring i området kring Öresundbron.- Fiskeriverket Utredningskontoret i Jönköping.
- WESTERBERG, H. (1994): Fiskeriundersökningar vid havsbaserat vindkraftverk 1990-1993. Fiskeriverket Utredningskontoret i Jönköping: 44 p.
- WESTERBERG, H. (2000a): Effect of HVDC cables on eel orientation. – In: MERCK, T. & NORDHEIM, H.V. (eds.): Technische Eingriffe in marine Lebensräume. Workshop des Bundesamtes für Naturschutz-INA Vilm 27.-29. Oktober 1999. – BfN Skripten 29: 70-76.
- WESTERBERG, H. (2000b): Impact Studies of Sea-Based Windpower in Sweden. - In: MERCK, T. & NORDHEIM, VON, T.: Technische Eingriffe in marine Lebensräume. BFN-Skripten 29, Bundesamt für Naturschutz, 163-168.
- WESTERBERG, H. & BEGOUT-ANRAS (2000): Orientation of silver eel (*Anguilla anguilla*) in a disturbed geomagnetic field. Advances in Fish Telemetry. - Proceedings of the Third Conference on Fish Telemetry in Europe, held in Norwich, England, 20-25 June 1999. Eds. Moore, A. & Russel, I. CEFAS, Lowestoft: 10 p.
- WESTERBERG, H., RÖNBÄCK, P. & FRIMANSSON, H. (1996): Effects of suspended sediments on cod egg and larvae and on the behaviour of adult herring and cod. – ICES CM 1996/E:26: 13 p.
- WILDISH, D.J. & POWER, J. (1985): Avoidance of suspended sediments by Smelt as determined by a new "single fish" behavioural bioassay. - Bull. of Environmental Contamination and Toxicology 34: 770-774.
- WILTSCHKO, R. & WILTSCHKO, W. (1995): Magnetic Orientation in Animals.- Zoophysiology 33: 297 p.
- WRIGHT, P.J., JENSEN, H. & TUCK, I. (2000): The influence of sediment type on the distribution of the lesser sandeel (*Ammodytes marinus*). – J. Sea Res. 44: 243-256.
- YANO, A., OGURA, M., SALTO, A. SAKAKI, Y., SHIMIZU, Y., BABA, N. & NAGASAWA, K. (1997): Effects of modified magnetic field on the ocean migration of maturing chum salmon, *Oncorhynchus keta*. - Mar. Biol. 129: 523-530.
- YOSHIMUDA, N. (1982): Discussion of installation planning. In: VIK, S.F. (1982): Japanese artificial reef technology. - Aquabio, Inc., 2957 Sunset Blvd., Bellair Bluffs, L. - Tech. Rep. 604: 137-165.
- ZUCCO, C. & MERCK, T. (2004): Ökologische Effekte von Offshore-Windkraftanlagen. - Naturschutz und Landschaftsplanung 36 (9): 261-269.





# Literature Review of Offshore Wind Farms with Regard to Seabirds

Volker Dierschke & Stefan Garthe

Forschungs- und Technologiezentrum Westküste

Universität Kiel

Hafentörn

25761 Büsum

[volker.dierschke@web.de](mailto:volker.dierschke@web.de); [garthe@ftz-west.uni-kiel.de](mailto:garthe@ftz-west.uni-kiel.de)

## Contents

<b>1</b>	<b>Summary</b> .....	<b>132</b>
<b>2</b>	<b>Zusammenfassung</b> .....	<b>133</b>
<b>3</b>	<b>Introduction</b> .....	<b>136</b>
<b>4</b>	<b>Methodology</b> .....	<b>137</b>
<b>5</b>	<b>Results</b> .....	<b>140</b>
	<b>5.1 Effects of Offshore Wind Farms on Seabirds</b> .....	<b>140</b>
	5.1.1 Barrier Effects for Flying Seabirds .....	140
	5.1.2 Collision Risk to Flying Seabirds .....	152
	5.1.3 Habitat Loss for Seabirds .....	157
	5.1.4 Habituation .....	169
	5.1.5 Summary of Species-Specific Effects of Offshore Wind Turbines on Seabirds .....	170
	<b>5.2 Quality of Studies and Results</b> .....	<b>175</b>
	<b>5.3 Effects of Other Technical Impact Factors on Seabirds in     Offshore Areas</b> .....	<b>177</b>
	5.3.1 Offshore Platforms .....	177
	5.3.2 Sand and Gravel Extraction .....	178
	5.3.3 Ship Traffic .....	178
<b>6</b>	<b>Discussion</b> .....	<b>180</b>
	<b>6.1 Collision Risk</b> .....	<b>180</b>
	<b>6.2 Habitat Loss</b> .....	<b>181</b>
	<b>6.3 Habitat fragmentation</b> .....	<b>184</b>
	<b>6.4 Assessment Methods</b> .....	<b>186</b>
	<b>6.5 Cumulative Effects</b> .....	<b>189</b>
	<b>6.6 Gaps in Knowledge and Need for Further Studies</b> .....	<b>189</b>
<b>7</b>	<b>Conclusions</b> .....	<b>191</b>
<b>8</b>	<b>References</b> .....	<b>192</b>
	<b>APPENDIX I (systematic list of species mentioned)</b> .....	<b>198</b>

## 1 Summary

With the prospect of many offshore wind farms planned in sea areas of north-western Europe, there is an increasing demand for information about their impact on the marine environment. Along with marine mammals and migrating birds, seabirds are in the focus of interest for scientists as well as for the public. In order to provide a comprehensive basis for the assessment of possible impacts from wind farms at sea, this report summarises the results of seabird studies conducted at already existing offshore wind farms (mainly Utgrunden and Yttre Stengrund in Sweden and Tunø Knob, Horns Rev and Nysted in Denmark) and discusses the extent and quality of the studies. Relevant results from coastal wind farms and other technical activities at sea are taken into account as well. The three main effects possibly affecting seabirds are: habitat loss due to disturbance, barrier effects, and fatal collisions.

According to recent studies, six out of the 35 seabird species regularly living in German waters strongly avoid offshore wind farms (Red-throated Diver, Black-throated Diver, Gannet, Common Scoter, Guillemot, Razorbill), and one other species (Long-tailed Duck) was recorded which showed much lower numbers in wind farm areas after construction than before. Seven species occur within wind farms which do not show any obvious effects, and three gull species even increased in numbers compared to the pre-construction period. For 18 seabird species, it is not known how and whether the wind farms affect their habitat use. Those species which do not occur in wind farm areas suffer habitat loss greater than the wind farm area itself, due to the distance they keep from the turbines. Physical habitat loss due to the introduction of a hard bottom fauna on foundations and scour protections seems to be of minor importance, but it is also not known whether, and if so to what extent, seabirds will make use of this new food supply, and also of attracted fish.

Information about flying seabirds is mostly restricted to migrating birds, which may behave differently to seabirds during local movements, such as foraging flights or flights to and from roosts. It appears that eight species (the same as those mentioned in the context of habitat loss, and also the Velvet Scoter and the Black Guillemot) commonly fly detours instead of crossing offshore wind farms. Detours were also noted for another four species, but it is not clear whether this happens regularly. A total of 15 species (mostly gulls and terns, but also staging Long-tailed Ducks and Red-breasted Mergansers) were found to fly through wind farms commonly; no information is available for eight species. Detours, especially if flown regularly, increase the energy consumption of seabirds, and it is even possible that the habitat fragmentation caused by the technical barriers will lead to their giving up certain sea areas.

Although one collision of Eiders was witnessed at a Swedish offshore turbine, no other information about mortality from collisions at offshore wind farms is available. As 13 seabird species belonging to different systematic groups were found as casualties at coastal wind farms, seabirds must fundamentally be regarded as vulnerable to collisions. However, collision rates, and hence estimates of additive mortality, remain to be investigated in future.

In addition to direct mortality, possibly occurring due to collisions, indirect effects may impact the population sizes of those seabird species which avoid offshore wind farms. If density-dependent effects lead to lower energy intake rates in replacement habitats after displacements from wind farm areas, the mortality rate should increase. In addition, carry-over effects may have negative impacts on the reproduction rate because of a possible connection between poor body condition on arrival and subsequent breeding success.

Proposed methodologies for the impact assessment at offshore wind farms are reviewed briefly and evaluated with respect to the recent results concerning seabirds at operating turbines. In general, assessment procedures can be improved by concentrating on those species which avoid wind farms. In addition, avoidance distances and thus the necessary sizes of buffer zones are now better known. However, as collision rates, effects of increased seabird densities at sea and possible habituation effects (most studies so far cover only one or two years of the operational period) are largely unknown, no methodologies yet exist which might help to fully assess these effects.

As the population sizes of seabirds are the comparative basis for the assessment of impacts, possible effects of offshore wind farms must be addressed in a cumulative approach, which cannot be restricted to other wind farms alone, but which must also consider such factors as disturbance and displacement by ship traffic and habitat loss due to sand and gravel extraction.

Open questions remain as to the behaviour of seabird species not covered by the recent studies and to seabird behaviour during adverse weather conditions (e.g. storms), when visibility and manoeuvrability may be negatively affected. In general, it appears that more direct observations (e.g. ship-based) should be undertaken in order to study avoidance and feeding behaviour of seabirds within wind farms. Furthermore, monitoring of prey species would help to get a better understanding of the distribution of seabirds in and around wind farms. However, in order to learn more about the impact of displacement and barrier effects on population sizes and population dynamics, fundamental studies of density effects in overwintering seabirds are essential.

## 2 Zusammenfassung

Mit der fortschreitenden Planung von Windparks in Seegebieten Nordwest-Europas besteht wachsender Bedarf von Kenntnissen über den Einfluss solcher Anlagen auf die Meeresumwelt. Neben Meeressäugtieren und Zugvögeln stehen dabei Seevögel im Mittelpunkt des Interesses, sowohl bei Wissenschaftlern als auch in der Öffentlichkeit. Als Basis für die Bewertung von möglichen Auswirkungen von Offshore-Windparks werden in diesem Bericht die Ergebnisse von relevanten Studien über Seevögel an bereits in Betrieb befindlichen Windenergieanlagen auf See (vor allem Utgrunden und Yttre Stengrund in Schweden sowie Tunø Knob, Horns Rev und Nysted in Dänemark) zusammengefasst, bewertet und diskutiert. Relevante Ergebnisse aus Windparks an der Küste bzw. in Küstennähe und von anderen technischen Eingriffen auf See werden ebenfalls berücksichtigt. Die drei wichtigsten Effekte, die wahrscheinlich auf Seevögel einwirken, sind Lebensraumverlust durch Scheuchwirkung, Barrierewirkung und tödliche Kollisionen.

Von den 35 regelmäßig in deutschen Gewässern (Hoheitsgewässer und Ausschließliche Wirtschaftszone) lebenden Seevogelarten zeigen nach bisherigen Ergebnissen sechs eine starke Meidung von Offshore-Windparks (Sterntaucher, Prachtaucher, Basstölpel, Trauerente, Trottellumme, Tordalk). Zudem kamen Eisenten in Windparks in niedrigerer Zahl vor als im selben Gebiet vor dem Bau der Anlagen. Sieben Arten kommen innerhalb von Windparks vor, ohne dass auffällige Effekte zu erkennen waren. Im Vergleich zur Zeit vor der Errichtung der Windenergieanlagen nahmen drei Möwenarten sogar zu. Für 18 der 35 Seevogelarten ist allerdings bisher unbekannt, inwiefern Lebensraumverlust durch Offshore-Windparks auftreten kann. Bei denjenigen Arten, die Windparks meiden, ist der nicht mehr nutzbare Lebensraum größer als die Windparkfläche selbst, da auch zu den am Rand stehenden Anlagen ein

Abstand eingehalten wird. Ein Verlust von Lebensraum durch die Einführung von Hartsubstrat (Fundamente und umgebende Schüttung) scheint dagegen unbedeutend zu sein. Bisher ist aber nicht bekannt, ob und in welchem Ausmaß Seevögel die neu entstandene Hartbodenfauna bzw. von ihr angelockte Fische als Nahrung nutzen.

Informationen über fliegende Seevögel beschränken sich zumeist auf ziehende Vögel, während das Verhalten bei lokalen Flugbewegungen (z. B. Nahrungs- und Schlafplatzflüge) weniger bekannt ist. Allem Anschein nach vermeiden es acht Arten (dieselben wie bei Lebensraumverlust, zusätzlich Samtente und Gryllteiste), Offshore-Windparks zu durchqueren und umfliegen diese stattdessen. Umwege wurden bei weiteren vier Arten festgestellt, doch ist nicht klar, wie regelmäßig diese auftreten. Insgesamt 15 Arten durchquerten für gewöhnlich Windparks, vor allem Möwen und Seeschwalben, aber auch in den entsprechenden Gebieten rastende Eisenten und Mittelsäger. Für acht Arten liegen keine diesbezüglichen Informationen vor. Umwege, besonders wenn sie regelmäßig in Kauf genommen werden müssen, erhöhen den Energieverbrauch der Seevögel. Außerdem ist denkbar, dass die technischen Barrieren zu Habitatfragmentierung führen und deshalb bestimmte Seegebiete als Lebensraum aufgegeben werden.

Außer der Beobachtung einer Kollision von ziehenden Eiderenten an einer schwedischen Windenergieanlage gibt es keine weiteren Informationen über Mortalität durch Kollisionen in Offshore-Windparks. Weil in küstennahen Windparks 13 verschiedene Seevogelarten aus verschiedenen systematischen Gruppen als Kollisionsopfer festgestellt wurden, müssen Seevögel grundsätzlich als kollisionsgefährdet eingestuft werden. Messungen tatsächlicher Kollisionsraten sowie Schätzungen zur hierdurch entstehenden additiven Mortalität und ihrer Wirkung auf Seevogelpopulationen sollten zukünftig vorrangig durchgeführt werden, um so fundierte Bewertungen der Auswirkungen von Kollision zu ermöglichen.

Zusätzlich zu direkter Mortalität durch Kollisionen können Populationen derjenigen Seevögel, die Offshore-Windparks meiden, von indirekten Einflüssen betroffen sein. Falls nach der Aufgabe der Windparkfläche dichteabhängige Effekte zu geringerer Energieaufnahme in Ersatzlebensräumen führen, könnte die Mortalitätsrate steigen. Da der Reproduktionserfolg – wie bei vergleichbaren Vogelarten gezeigt – mit der Körperkondition im Winterquartier und während des Heimzuges zusammenhängen kann, ist auch eine negative Beeinflussung der Populationsdynamik auf Seiten der Fortpflanzung denkbar.

Methoden, die zur Bewertung der Einflüsse von Offshore-Windparks auf Seevögel vorgeschlagen wurden, werden im Licht der Ergebnisse operierender Windparks zusammenfassend betrachtet. Grundsätzlich gewinnen diese Verfahren an Wert, wenn sie sich auf die Windparks vermeidenden Arten konzentrieren. Außerdem erlaubt eine inzwischen bessere Kenntnis von zu Windenergieanlagen eingehaltenen Abständen eine bessere Abschätzung der Größe von Pufferzonen. Da aber weder Kollisionsraten noch Gewöhnungseffekte – die meisten Studien beziehen sich nur auf die ersten 1-2 Jahre der Betriebsphase – bekannt sind, gibt es bisher keine Methode, die langfristige Folgen für Seevogelpopulationen vorhersagen kann.

Weil die Populationsgrößen von Seevögeln der Maßstab sind, an denen die Auswirkungen von Eingriffen zu messen sind, müssen mögliche Einflüsse von Offshore-Windparks kumulativ betrachtet werden. Der kumulative Ansatz darf sich dabei nicht nur auf andere Windparks beschränken, sondern muss auch andere Eingriffe, die auf Seevogelpopulationen einwirken, einschließen (z. B. Störung und Vertreibung durch Schiffsverkehr, Lebensraumverlust durch Sand- und Kiesabbau).

Offene Fragen bestehen hinsichtlich des Verhaltens der Seevogelarten, die bei den dänischen und schwedischen Studien nicht berücksichtigt wurden bzw. dort nicht vorkommen, aber auch zur bislang völlig unbekanntem Situation bei schlechtem Wetter (z. B. Sturm), wenn Sicht und Manövrierfähigkeit der Vögel stark beeinträchtigt sind. Ganz allgemein sollten zukünftig mehr direkte Beobachtungen (z. B. von Schiffen aus) unternommen werden, um das Verhalten sowohl bei Meidereaktionen als auch bei der Nahrungssuche innerhalb von Windparks genauer zu untersuchen. Zusätzlich könnte ein Monitoring der Beutearten ein sehr viel besseres Verständnis der Seevogelverteilung in und um Windparks fördern. Um allerdings mehr über die Einflüsse von Lebensraumverlust und Barrierewirkung auf die Populationsgröße von Seevögeln zu erfahren, sind grundlegende Studien zu Dichteeffekten bei überwinternden Seevögeln unerlässlich.

### 3 Introduction

Seabirds play an important role in the assessment of the possible impacts of offshore wind farms on the marine environment. Despite numerous studies of the consequences of on-shore wind turbines for birds (most recently reviewed by HÖTKER *et al.* 2004 and PERCIVAL 2005), the in many respects different biology of seabirds generally limits the extend to which results from studies at land can be applied to offshore wind farms. Seabirds include breeding birds from coastal areas and islands which undertake foraging flights to the open sea as well as birds living there to overwinter, moult or stop over during migration. Habitat loss (displacement due to disturbance by operating turbines and associated ship and helicopter traffic, or habitat alteration by artificial creation of hard-bottom substrate), habitat fragmentation due to barrier effects during flight (disturbance by operating turbines) and additional mortality (collision with turbines) are regarded as the most important possible impact factors (GARTHE 2000, NOER *et al.* 2000, EXO *et al.* 2002).

To date, fairly few of the offshore wind farms built since the early 1990s have been studied with respect to their effects on seabirds. This review intends to summarise the knowledge of seabird reactions to operating offshore turbines, and to discuss the universality of the results of published impact studies. As similar effects may arise from related impacts, relevant studies of offshore platforms, ship traffic and aggregate extraction are likewise considered. The general focus of this review is on the 35 seabird species which regularly live in the German parts of North and Baltic Seas – the 12-mile zone plus the Exclusive Economic Zone (GARTHE *et al.* 2003a, see also Table 2).

Several methods for the assessment of possible impacts of offshore wind farms on seabirds have been proposed (e.g. NERI 2000, PERCIVAL 2001, DIERSCHKE *et al.* 2003, GARTHE & HÜPPOP 2004). Of special interest is the question as to whether the results from studies at existing turbines correlate with the assumptions included in these methods, and whether modifications and a review of these methods appears necessary. Furthermore, the possible consequences of the observed effects on the population dynamics of the respective seabird species are discussed.

## 4 Methodology

This report summarises the results of studies on seabirds at offshore wind farms in construction and operation. Some of the studies are still in progress, and results were only considered here if published before 30 June 2005. Despite of the fact that a considerable number of offshore wind farms (Fig. 1) exists, only few of them were studied with regard to effects on seabirds during construction and/or operation. This report therefore mainly relies on results obtained at five offshore wind farms (for technical details see Table 1):

- **Tunø Knob** (Århus Bay, Baltic Sea, Denmark, operating since autumn 1995, GUILLEMETTE *et al.* 1998),
- **Utgrunden** (Kalmar Sound, Baltic Sea, Sweden, operating since December 2000, PETTERSSON & STALIN 2002),
- **Yttre Stengrund** (Kalmar Sound, Baltic Sea, Sweden, operating since September 2001, PETTERSSON & STALIN 2002),
- **Horns Rev** (west of Jutland, North Sea, Denmark, operating since the last quarter of 2002, PETERSEN *et al.* 2004),
- **Nysted** (south of Lolland, Baltic Sea, Denmark, operating since August 2003, KAHLERT *et al.* 2004b).

In addition, observations at the semi-offshore Lely wind farm in the IJsselmeer, in the Netherlands were included (DIRKSEN *et al.* 1998c). Finally, effects of wind turbines on seabirds were studied at some wind farms which were built directly at the coastline or close to it. Results obtained there can also give indications on the effects that can be expected from offshore wind farms, especially with respect to flight behaviour, potential barrier effects and collision risk.

Table 1: Technical details of the five offshore wind farms, at which the majority of information about seabirds was gained (data from various reports and websites).

	Tunø Knob	Utgrunden	Yttre Stengrund	Horns Rev	Nysted
location	Århus Bay, DK	Kalmar Sound, S	Kalmar Sound, S W	of Jutland, DK	S. of Lolland, DK
wind farm area	0.3 km <sup>2</sup>	–	–	20 km <sup>2</sup>	24 km <sup>2</sup>
wind farm extension	0.8 km	2.2 km	1.5 km	5.0 km	6.0 km
water depth (m)	3 - 5 m	7 - 10 m	6 - 10 m	6.5 - 13.5 m	6 - 9.5 m
closest distance from coast	3 km	8 km	5 km	14 km	10.5 km
closest distance between turbines	200 m	?	?	560 m	480 m
number of turbines	10	7	5	80	72
power per turbine	0.5 MW	1.5 MW	2 MW	2 MW	2.3 MW
total height	60 m	101 m	96 m	110 m	110 m
Hub height	40.5 m	65 m	60 m	70 m	69 m
rotor diameter	39 m	70.5 m	72 m	80 m	82 m

In general, the results (e.g. figures and values) were taken as shown in the reports on seabird studies. Sometimes, additional values had to be worked out from figures listed in the reports. For example, in the reports about seabirds at the Horns Rev and Nysted wind farms, bird numbers are given for three partial areas in comparison to the whole area surveyed: wind farm; wind farm plus 2 km radius; and wind farm plus 4 km radius.

In order to compare the development of bird numbers in the 2-km-zone (not counting the wind farm) and the 4-km-zone (not counting the wind farm or 2 km zone), the respective values were calculated from the data shown in the reports.

A systematic list of species mentioned in this report is shown in Appendix I.

**Acknowledgements:** This report has been aided by discussions with and support from C. ZUCCO, T. MERCK and I. KÖCHLING of the German Federal Conservation Agency, the Seabird Group in the Forschungs- und Technologiezentrum Westküste (West Coast Research & Technology Centre) and other colleagues working on environmental questions regarding offshore wind farms in Germany and Denmark. Unfortunately, information flow has been very poor, apart from published reports. Many requests for information were not answered, especially by energy companies.

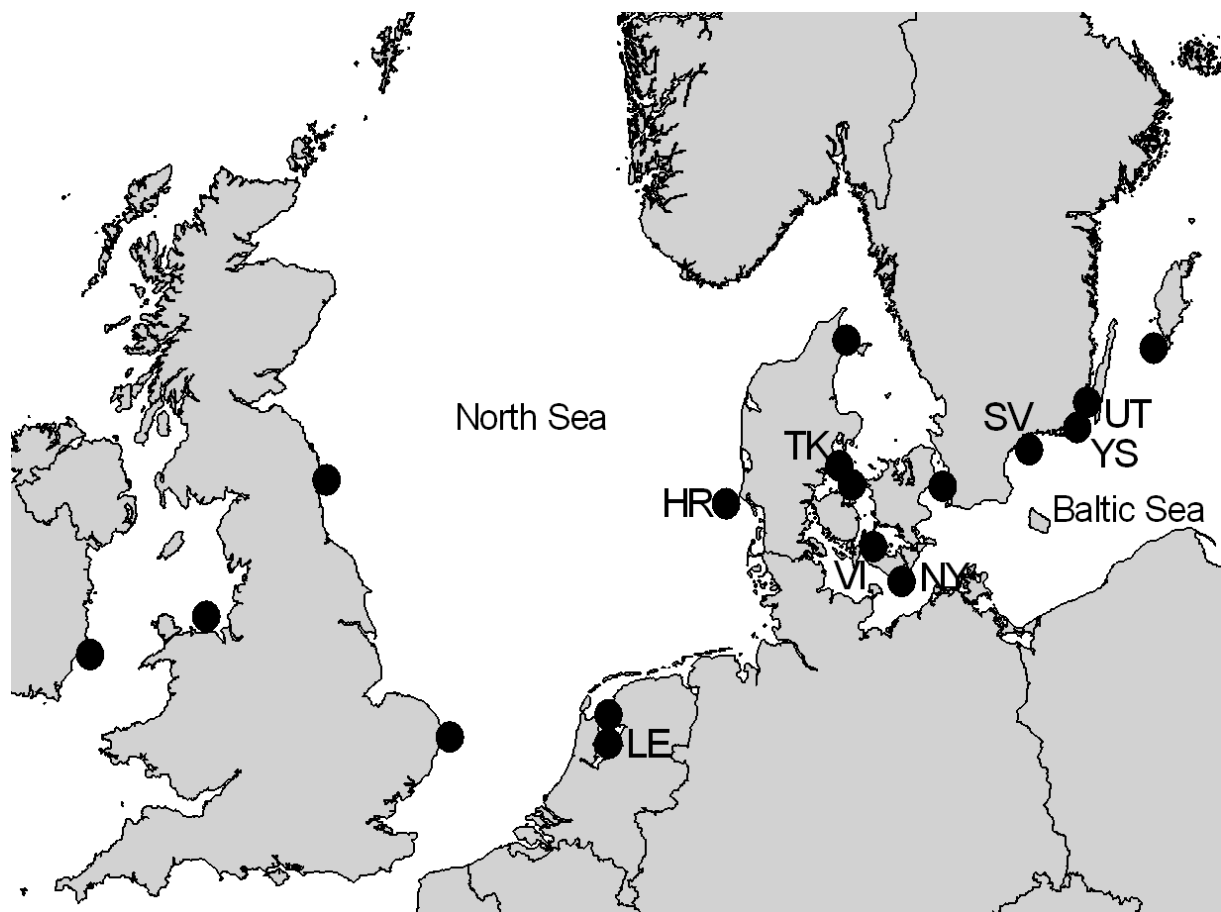

Fig. 1: Offshore and semi-offshore wind farms operating as of June 2005. Wind farms mentioned in this report are indicated as follows: SV Svante, VI Vindeby, TK Tunø Knob, LE Lely, UT Utgrunden, YS Yttre Stengrund, NY Nysted, HR Horns Rev.



Table 2: Overview of seabirds (35 species regularly occurring in German waters, GARTHE *et al.* 2003a) covered by studies on barrier effects (B), collision risk (C) and habitat loss (H) at offshore wind farms. Species listed in Annex I of the EU Birds Directive are printed bold. Coast: relevant studies from coastal wind farms (<5 km inland; C only with respect to proved collisions). \* Species only considered as part of a species group; <sup>1</sup> only migrating birds (no local movements); in brackets: small sample size or fragmentary information. Note that a notification does not necessarily mean that there are appropriate results, because insignificant information was often provided.

	Tunø Knob	Utgrunden	Yttre Stengrund	Horns Rev	Nysted	Coast
<b>Red-throated Diver</b>		(B <sup>*1</sup> ) (H <sup>*</sup> )	(H <sup>*</sup> )	B <sup>*1</sup> H <sup>*</sup>		B C
<b>Black-throated Diver</b>		(B <sup>1</sup> ) (H <sup>*</sup> )	(H <sup>*</sup> )	B <sup>*1</sup> H <sup>*</sup>		
Great crested Grebe						
Red-necked Grebe				(B <sup>1</sup> )		
<b>Slavonian Grebe</b>		(B <sup>1</sup> )	(B <sup>1</sup> )			
Fulmar				(B <sup>1</sup> )		B C
Sooty Shearwater				(B <sup>1</sup> )		
Gannet				B H		
Cormorant	(H)	B (C <sup>1</sup> ) (H)	B <sup>1</sup> (C <sup>1</sup> ) (H)	B <sup>1</sup> C <sup>1</sup> H	B H	B C
Greater Scaup		(B <sup>1</sup> ) (H <sup>*</sup> )	(B <sup>1</sup> ) (H <sup>*</sup> )			B <sup>*</sup>
Eider	B H	B C <sup>1</sup> H	B <sup>1</sup> C <sup>1</sup> (H)	B <sup>1</sup> (H)	B H	B C
<b>Long-tailed Duck</b>		(B) H			B H	
Common Scoter	(H)	H		B C H		
Velvet Scoter		(B <sup>1</sup> )	(B <sup>1</sup> ) (H)	B <sup>1</sup>		
Red-breasted Merganser		(B <sup>1</sup> ) H	B <sup>1</sup> (H)	B <sup>1</sup>	B	
Pomarine Skua						
Arctic Skua		(B <sup>1</sup> )		B C		
Great Skua				(B <sup>1</sup> )		
<b>Little Gull</b>				B <sup>1</sup> H	B <sup>*1</sup>	
Black-headed Gull				B <sup>1</sup> C <sup>*1</sup>	B <sup>*1</sup>	B C
Common Gull				B <sup>1</sup> C <sup>*1</sup>	B <sup>*1</sup>	B <sup>*</sup> C
Lesser Black-backed Gull		(B <sup>1</sup> )	(B <sup>1</sup> )	B <sup>1</sup> C <sup>*1</sup>	B <sup>*1</sup>	B C
Herring Gull				B C H	B <sup>*1</sup> H	B C
Great black-backed Gull				B C H	B <sup>*1</sup>	B C
Kittiwake		(B <sup>1</sup> )	(B <sup>1</sup> )	B <sup>1</sup> C <sup>*1</sup> H		B C
<b>Caspian Tern</b>		(B <sup>1</sup> )	(B <sup>1</sup> )			
<b>Sandwich Tern</b>				B C <sup>*1</sup>	B <sup>1</sup>	B
<b>Common Tern</b>			C <sup>*1</sup>	B <sup>*</sup> C <sup>*1</sup> H <sup>*</sup>		B C
<b>Arctic Tern</b>			C <sup>*1</sup>	B <sup>*</sup> C <sup>*1</sup> H <sup>*</sup>		
<b>Black Tern</b>						B C
Guillemot				B <sup>*1</sup> H <sup>*</sup>		C
Razorbill				B <sup>*1</sup> H <sup>*</sup>		
Black Guillemot		(B <sup>1</sup> )				
Little Auk						
Puffin						

## 5 Results

### 5.1 Effects of Offshore Wind Farms on Seabirds

#### 5.1.1 Barrier Effects for Flying Seabirds

Except for the Tunø Knob wind farm, the question of barrier effects at offshore wind farms was studied only for migrating birds (including seabirds). However, results about avoidance reactions shown by seabirds during flight at Utgrunden, Yttre Stengrund, Nysted and Horns Rev may in part be valid for non-migratory flights of seabirds as well. For instance, high proportions of seabirds flying southwards in spring and northwards in autumn suggest that observations at Horns Rev in some cases involve staging birds. This is especially true for the Common Scoter which is present around the wind farm area in very large numbers. The behaviour of seabirds observed at coastal wind farms may also be transferred to offshore situations, hence the respective studies are considered here as well. Despite the inclusion of the latter studies, no information on possible barrier effects is available for a number of species (Table 2). Consequences of detours and changes in flight altitude of affected birds on the energy budget are dealt with not here, but in a parallel study on migrating birds (HÜPPOP *et al.* 2005).

#### Tunø Knob, Denmark

The flight activity of Eiders (locally wintering birds) was observed with radar at night and during twilight from December 1998 to April 1999 (TULP *et al.* 1999). As for the observations concerned wintering and staging birds, the flights can be regarded as local movements within a staging area. High flight activity was noted especially at dawn (flights to display areas) and on moonlit nights, but was much lower on dark nights. Nocturnal flight activity was low within a distance of 1000-1500 m from the wind farm, but higher than expected at a distance of 1500 m, probably due to a concentration of evading birds. Such an effect was already observable at 1200 m distance at dusk, but was absent (or below 200 m distance) at dawn. The avoidance reactions occurred on all sides of the wind farm and were therefore independent of the location of the areas used for resting and foraging, respectively. Not only the wind farm area (0.3 km<sup>2</sup>), but also a large area around the wind farm (approx. 12.9 km<sup>2</sup>) was avoided by Eiders.

Flights within a distance of 500 m around the wind farm were analysed more precisely. With increasing darkness, fewer flights occurred between the turbines. Eiders much more often entered the wind farm parallel to the two rows of turbines (mostly through the 400 m wide gaps between the rows) than perpendicular to the turbine rows, between the 200 m wide gaps. Irrespective of light conditions and flight direction, more flocks flew outside than inside the wind farm. A directional change was observed in 6.5-7.5% of the flocks observed, and more often on moonlit than on dark nights.

The authors conclude from their results that with regard to nocturnal movements of local Eiders, the wind farm acts as a barrier, which is actively avoided. In daytime, such avoidance seemed to be restricted to a distance of about 100 m from the wind farm (GUILLEMETTE *et al.* 1998, see 5.1.3).

## Utgrunden, Sweden

Observations of flying birds nearly exclusively refer to migration, which takes many seabirds along the 20 km wide Kalmar Sound in the spring and autumn. Diurnal migration was monitored visually during parts of the spring seasons of 1999 (pre-construction), 2001, 2002 and 2003 (operation); and during parts of the autumn seasons of 2000 (construction) and 2002 (operation), from the mainland and Öland coastlines as well as from the lighthouse located in the middle of the Sound. Using data from a nearby military radar station, the flight paths of migrating bird flocks were recorded during daytime and nighttime hours, but the calibration of the radar allowed only the tracking of large and/or high flying bird flocks (at least 45-100 Eiders, PETTERSSON 2005). All results mentioned refer to the reports by PETTERSSON (2001, 2002, 2003, 2005).

During visual observations, the Kalmar Sound was divided into four zones with widths of 5 km each (A, B, C, D from west to east). The outer zones were observed from the respective coastlines, and the inner two zones from the lighthouse. During spring migration, Eiders were by far the most abundant seabirds (e.g. Table 3). In the pre-construction phase (spring 1999), Zone C was preferred by Eiders (37% of all birds), but the same zone was strongly avoided after seven turbines had been built there parallel to the direction of flight (7% in 2001 and 6% in 2002-2003 of all birds observed, see Fig. 2 and Table 3: decreases in Zone C and increases in Zone D significant). Within Zone C, the spring migration of Eiders was distributed evenly over five 1 km wide sub-zones before construction, but the three sub-zones in which turbines were located were clearly avoided during operation, and the sub-zone closest to the turbines was also used to a much lesser degree (Fig. 3). Compared to the first post-construction spring (2001), a slight increase in the number of Eiders passing between or over the turbines (sub-zones 3-5) was noted. Eiders usually detoured the wind farm, altering their course by 1-2 km in front of the turbines and keeping a distance of at least 500 m from them (of the total 10,654 waterbird flocks observed during spring migration, only 3.1% approached closer than 500 m to a turbine, and only 0.3% passed at approximately 100 m distance). Detours ranged between 1.2 and 2.9 additional kilometres flown. Of those Eider flocks which came close to the wind farm, some crossed between the turbines, preferably at those temporarily not operating (Fig. 4). On a day on which Eider migration proceeded perpendicularly to the row of turbines, 6% of the flocks passed in between and 9% above the turbines; all the other flocks flew around the wind farm. No Eider approached a turbine more closely than 100 m.

Autumn migration of Eiders took place along the mainland coast during construction and operation of the wind farm. It seems that this was the commonly used route, even before construction. Eiders heading towards the wind farm in autumn already changed their flight direction 3-4 km in front of the turbines and kept a distance of about 1 km from them, with detours of a few hundred metres to 1 km flown additionally. As in the spring, the few birds flying in Zone C avoided the three sub-zones containing the wind farm. Radar observation in daylight confirmed the long detours flown by Eiders in the spring and autumn.

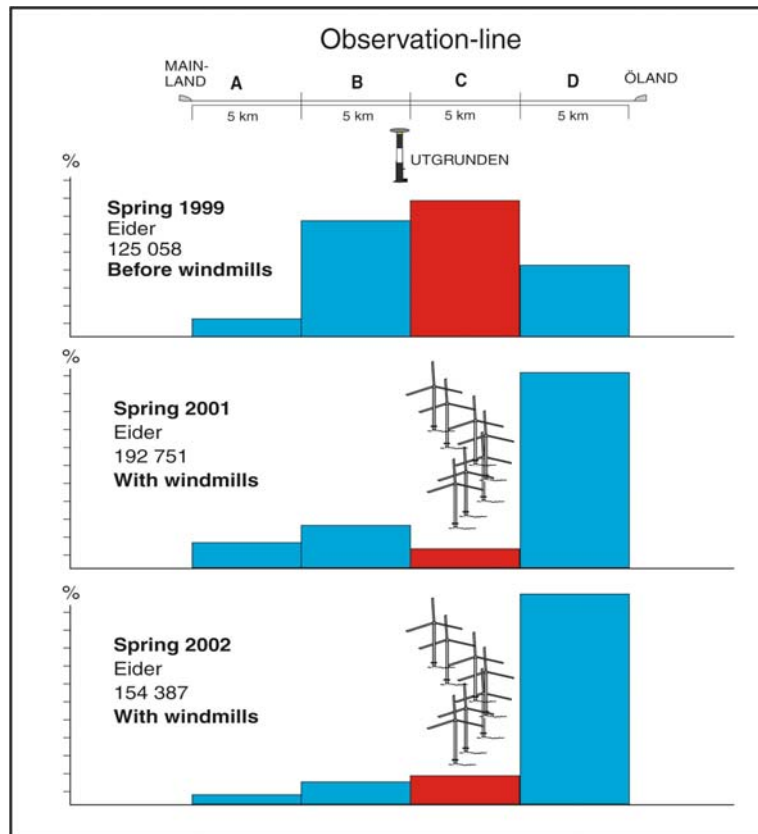

Fig. 2: Distribution of spring-migrating Eiders over four 5 km wide zones in the Kalmar Sound between Öland and the Swedish mainland coast, before and after construction of the Utgrunden wind farm (seven turbines) in Zone C in December 2000. From PETERSSON & STALIN 2002.

Table 3: Distribution of spring migrating seabirds on four 5 km wide zones of Kalmar Sound before (1999) and after (2001) construction of the Utgrunden wind farm. The turbines were built in Zone C (printed bold for comparison), for the location of the four zones see Fig. 2. Data from PETERSSON (2002), but birds migrating over land were omitted from the analysis. The differences between the yearly proportions in Zone C are significant for all species ( $\chi^2$  tests calculated with data from PETERSSON 2002).

	Spring 1999 (pre-construction)					Spring 2001 (operation)				
	A	B	<b>C</b>	D	n	A	B	<b>C</b>	D	n
Divers	1%	72%	<b>16%</b>	11%	580	3%	87%	<b>4%</b>	5%	705
Cormorant	46%	23%	<b>22%</b>	9%	807	57%	13%	<b>14%*</b>	17%	1819
Eider	5%	34%	<b>40%</b>	21%	120087	8%	14%	<b>6%</b>	72%	179341
Red-breasted Merganser	22%	19%	<b>18%</b>	41%	754	18%	22%	<b>4%</b>	56%	1532

\* PETERSSON (2005) states an increase to 25% for Cormorants in Zone C in the spring seasons 2001-2003. However, the data in his Table 16 suggest that only some 10-11% of the Cormorants were recorded in this zone.

Compared to Eiders, the pooled results obtained for other large birds (with Cormorant and Red-breasted Merganser reported as being the most abundant) are very much the same. Details of the distribution over the four zones of Kalmar Sound are given for divers, Cormorant and Red-breasted Merganser, which all showed decreased proportions of birds migrating in Zone C in spring after the wind farm had been built (Table 3). Before construction, 28% of all waterbirds (except Eiders) migrated in Zone C, but many switched to zone D during operation, with only 6% recorded in Zone C in 2001, and 17% in 2002-2003.

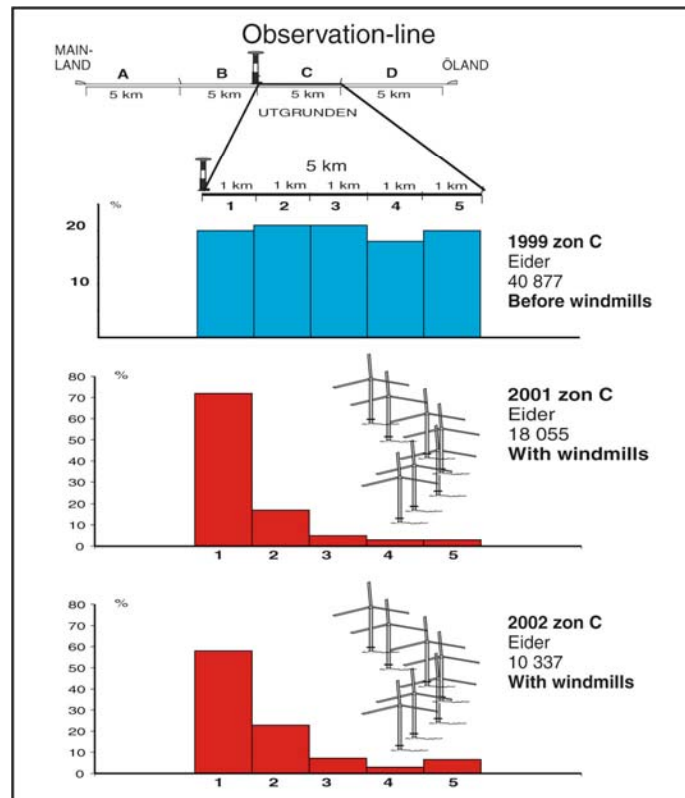

Fig. 3: Distribution of spring migrating Eiders over five 1 km wide sub-zones of zone C in the Kalmar Sound (compare Fig. 2) before and after the construction of seven turbines in the sub-zones 3, 4 and 5 in December 2000. Taken from PETTERSSON & STALIN 2002.

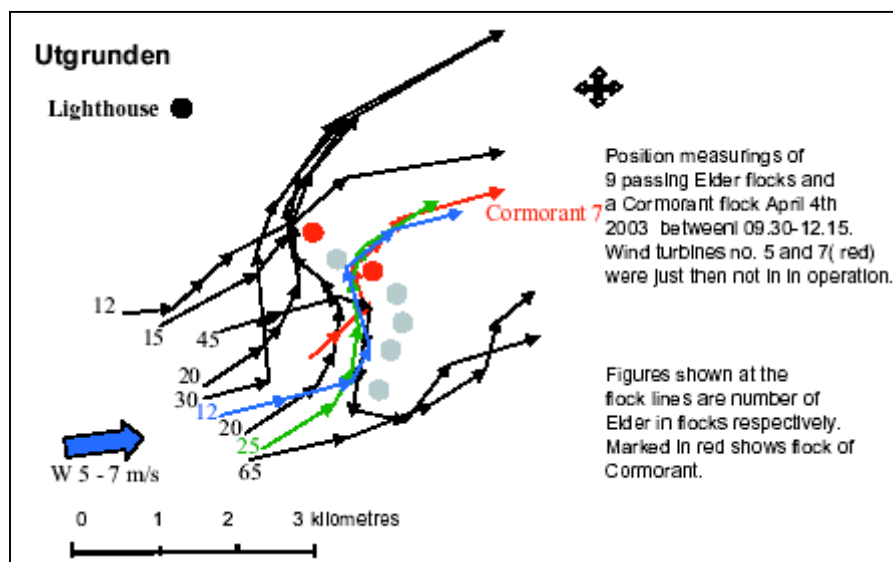

Fig. 4: Flight paths of Eiders and Cormorants tracked by optical rangefinder at the Utgrunden wind farm in Spring 2003 (taken from Petterson 2005).

In autumn, divers (mostly Black-throated Divers), scoters, auks and Arctic Skuas preferred to fly in the middle of the Sound, but avoided getting close to the wind farm. Cormorants and Red-breasted Mergansers crossed the wind farm more often than other seabirds. Bird flocks tracked by radar revealed flights round the wind farm at daytime and nighttime, and during both good and poor visibility, indicating that birds are able to detect wind turbines even in darkness and fog. However, an increased rate of flight paths passing straight through the wind farm was observed during fog during daytime. The species involved were unknown in these cases. Regarding the distribution of migrating birds over the sub-zones of Zone C, data are presented for some rare species (but unfortunately not for the common ones). Accordingly, it appears that Velvet Scoters and Black Guillemots avoid the wind farm area, whereas Greater Scaups were flying in the sub-zones containing the turbines (Table 4).

With respect to local wintering birds, the general statement is that Eiders, Long-tailed Ducks and Cormorants which forage in the shallow water around the wind farm area commonly fly back and forth between the turbines. However, quantitative data are not available for staging birds, because the vast majority of results mentioned above refer to actively migrating birds. The question as to the extent to which a barrier effect for staging birds can be deduced from the visual and radar observations at Utgrunden remains open.

Table 4: Number of seabirds migrating through sub-zones outside (1, 2) and inside (3, 4, 5) the Utgrunden wind farm before and after the construction of the turbines. S spring, A autumn.

	Season	Pre-Construction		Operation	
		outside WF	WF sub- zone	outside WF	WF sub-zone
Slavonian Grebe	S + A	0	0	4	0
Greater Scaup	A	0	0	0	14
Velvet Scoter	S + A	11	21	41	0
Lesser Black-backed Gull	S	2	2	3	0
Kittiwake	A	0	0	1	0
Caspian Tern	S	0	0	1	0
Black Guillemot	S + A	8	4	34	0

### Yttre Stengrund, Sweden

Due to the proximity to the Utgrunden wind farm, visual observations of diurnal migration and radar tracking were conducted for both wind farms combined. As at Utgrunden, flying birds at Yttre Stengrund were for the most part actively migrating birds, and the area is hardly used by staging seabirds (see 5.1.3). Observations of bird migration were carried out during the pre-construction period (autumn 2000, spring 2001) and the operational period (autumn 2001, spring and autumn 2002, spring 2003). All results are from PETERSSON (2002, 2003, 2005).

In the southern Kalmar Sound, observations were carried out only from the mainland coast. Migrating birds in zone A (mainland side, see Utgrunden) were assigned to four sub-zones with a width of 1-1.5 km each (1, 2, 3, 4). During the autumn of 2000, Eiders and other seabirds (species composition not given) were distributed equally over the four sub-zones. After the five turbines were built in sub-zone 3, this sub-zone was avoided nearly completely by Eiders (2000: approx. 20% of all flocks, 2001: no flocks at all, 2002: three flocks only; see also Table 5). Not a single flock crossed the wind farm; instead the birds evaded it, shifting to sub-zones 2 (2001) and 4 (2002). In doing so,

they only exceptionally came closer to the turbines than 500 m. Detours started at about 800-1000 m in front of the wind farm and caused prolonged flights of 1.2-3 km. Seven (out of 756) Eider flocks behaved indecisively before passing. During the spring, the proportion of Eider flocks flying in the wind farm sub-zone decreased as well, from 13% before construction (2001) to only 2% during operation (2002). Detours tracked by radar during the spring revealed flight paths approximately 2 km longer.

Other seabirds also avoided sub-zone 3 during autumn migration (after construction, only 3% of all flocks, compared to 9% before construction) and flew around the wind farm on both the eastern and western sides. Red-breasted Mergansers are reported as flying through the wind farm, and migrating Common/Arctic Terns were found to fly close to and between turbines without showing "great deviation manoeuvres". Although Cormorants were scarce in sub-zone 3 before construction, the proportion of birds using this section decreased from 2.5% to 0.3% (Table 5). A much stronger decrease in sub-zone 3 was noted for Velvet Scoters (from 22.6% during pre-construction to 5.4% during operation), but 20.3% of Greater Scaups migrated in this zone with operating turbines (Table 5). During spring migration, sub-zone 3 was generally used by only few birds (approx. 3% of all flocks) before construction, and this proportion was even smaller during operation (approx. 1%). According to radar observations, seabirds (most probably including Eiders) were flying around the wind farm even at night (mostly on the eastern side) and on foggy days (on both sides).

Table 5: Number of seabirds migrating through sub-zones outside (1, 2, 4) and inside (3) the Yttre Stengrund wind farm before and after the construction of the turbines. S spring, A autumn.

	Season	Pre-construction		Operation	
		Outside WF	WF sub-zone	Outside WF	WF sub-zone
Slavonian Grebe	S + A	2	0	5	0
Cormorant	A	1383	35	3290	11
Greater Scaup	S + A	60	0	121	31
Eider	A	42290	2611	122512	647
Velvet Scoter	S + A	188	55	353	20
Lesser Black-backed Gull	A	3	0	17	0
Kittiwake	A	0	0	1	0
Caspian Tern	S + A	1	0	3	0
Black Guillemot	S	1	0	0	0

### Nysted, Denmark

Radar tracking of birds flying at the Nysted wind farm is available from the pre-construction period (1999-2002), during construction (spring 2003), and from the operational period (autumn 2003, spring 2004; KAHLERT *et al.* 2004a, 2004b). The radar equipment was based on an observation tower 5 km northeast of the wind farm. The results presented in the reports mostly refer to actively migrating waterbirds, including species not considered seabirds in this review, because the radar tracks were assigned to this group due to their flight speed. The migration of waterbirds generally took place along an east-west axis. During the spring, Eiders made up 48% of all flocks during operation (61-90% in the preceding years), and their share was 45% in the autumn (all years combined). A large proportion (31%) of autumn flocks involved foraging flights by Cormorants, which rested on the nearby Rødsand; local staging Red-breasted Mergansers were also involved. The analysis of radar data concentrated on directional

changes of flight paths and the proportions of flocks crossing the eastern border of the wind farm.

During **autumn migration**, the general route of migrating waterbirds turns westward after passing the southern tip of Falster and brings birds towards the wind farm area in a broad front. Before construction, they crossed this area in a straight line, but during construction and operation they have flown around the wind farm (Fig. 5). Because detours to the north and to the south occurred concurrently, the average flight direction remained the same, but the response to the turbines could be measured as an increasing standard deviation when approaching the wind farm. Accordingly, directional changes started mainly at a 1 km distance at night and at a 3 km distance during daytime. The probability of crossing the eastern border when approaching from the east varied between 23.9% and 48.1% during the pre-construction period, but fell to 8.9% (daytime: 4-7%; nighttime: 11-24%) during operation. The difference between the two periods is significant, even when accounting for side winds, time of day and the position of flocks during the approach. The migration intensity (length of all flight paths measured in a monitoring area divided by the number of flocks flying in across the eastern border) decreased from pre-construction to operation within the wind farm, but remained the same in a control area outside the wind farm. Visual observations at the radar station northeast of the wind farm showed that 3% of Eider flocks were heading back towards the east during operation, almost the same as in the years prior to construction.

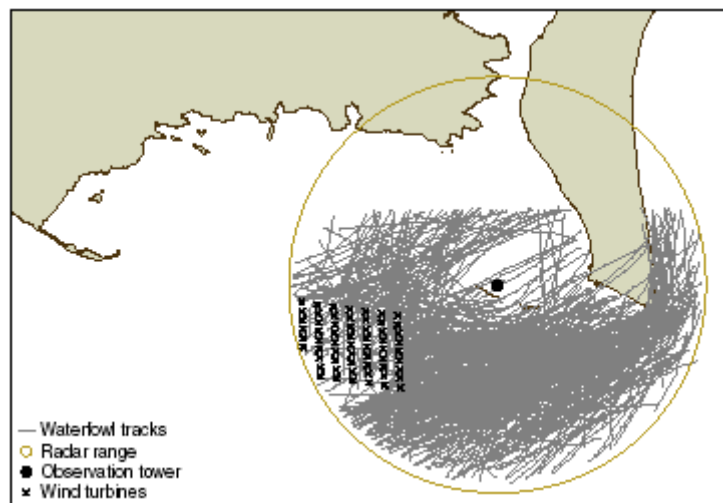

Fig. 5: Radar registration of 508 waterbird flocks visually ascertained at the Nysted wind farm during the autumn of 2003 (operational period). From KAHLERT *et al.* 2004b.

**Spring migration** usually takes place closer to the south coast of Lolland, and thus mainly north of the wind farm area. However, during the pre-construction period, 16% (2001) and 25% (2002) of waterbird flocks crossed the eastern border of the wind farm. This proportion was lower during construction (11%) and operation (11%), and it can be assumed that these birds flew through the wind farm. Differences between the pre-construction period and the construction or operational periods, respectively, are significant only for nocturnal migration.



From statements in the reports, it can be concluded that the results refer mainly to migrating birds, but also include local staging birds (Cormorant, Eider, Long-tailed Duck, Red-breasted Merganser and gulls are mentioned). Radar tracking was only considered in the analysis when it could be followed for at least 5 km. This suggests that an even lower proportion of staging birds is included in the results. It could not be ascertained whether staging birds behaved similarly to migrating birds. Therefore, a general transfer of the results to barrier effects on staging birds is not possible, except for foraging flights by Cormorants (see 5.1.3).

### Horns Rev, Denmark

According to the published reports (CHRISTENSEN *et al.* 2004, CHRISTENSEN & HOUNISEN 2004, 2005), movements of birds were recorded from a transformer station at the northeastern edge of the wind farm, using both radar (August 2003 to May 2004, total of 195 hours, both daytime and nighttime) and visual equipment (August 2002 to May 2004, total of 169 hours). Visual observations during the daylight period were conducted along four transect lines, of which one ran along the easternmost row of turbines, one across the wind farm, and two outside the wind farm (Fig. 6); the birds crossing the transect lines were counted.

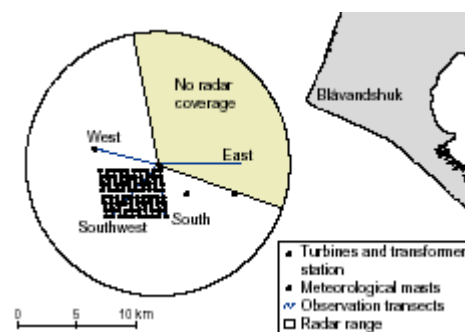

Fig. 6: Transect lines observed visually from the transformer station at the Horns Rev wind farm (from CHRISTENSEN *et al.* 2004).

Radar observations during the autumn demonstrated that birds approaching the wind farm significantly altered their flight direction. When approaching the northern edge of the wind farm, they changed their flight direction from SW to S (with the most apparent point of deflection at a distance of 400 m from the wind farm) and when heading towards the eastern edge of the wind farm, they changed their flight direction from SW to W. These manoeuvres resulted in detours around the southeastern and northwestern corners of the wind farm, as well as in entering the wind farm perpendicular to the turbine rows. Thus, the few flocks which actually entered the wind farm (13.9% of approaches from the north and 21.9% of approaches from the east) chose to fly through the centre between the rows of turbines. Entrance to the wind farm occurred independently of wind conditions and time of the day (day/night). During the spring of 2004, directional changes of birds flying southwards mainly occurred 400-500 m in front of the wind farm. With much less data than in 2003, the proportion of flight paths leading into the wind farm was 0% from the north and 29% from the east. Northbound spring migration was also found to be deflected well before the wind farm, tentatively estimated at a 4-6 km distance.

During visual observation, none of the 70 divers recorded crossed those two transect lines, which indicate flights through the wind farm. The two single divers tracked by radar passed at a distance of 900 m or made a U-turn 1 km before the wind farm, respectively. Very low proportions of individuals flying within the wind farm were also observed for Gannets (1.1%), Common Scoters (1.1%), Velvet Scoters (0.6%) and Guillemots/Razorbills (3.8%). While flight paths of 16 individuals or flocks of Gannets tracked by radar confirmed avoidance of the wind farm, Common Scoter flight paths were also recorded between the turbines. However, more flight paths were found outside the wind farm (where many birds were staging during the spring of 2004); within the wind farm, unexpected turns occurred (Fig. 7). In addition, in a sample of 20 flocks approaching the wind farm, all birds reacted to the turbines by changing their flight directions (mostly at 200-500 m distance). Large proportions of individuals flying in or into the wind farm were observed for Arctic Skuas and most species of gulls and terns (24-51%), with the exception of Little Gulls (13%, Table 6). Flight paths of gulls and terns recorded by radar confirm frequent entry to the wind farm.

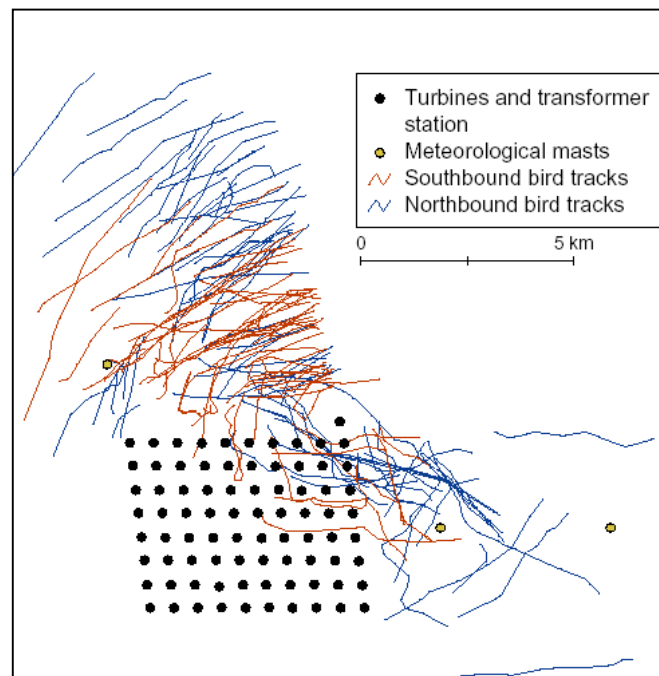

Fig. 7: Radar tracking of Common Scoters ( $n = 138$  individuals/flocks) at the Horns Rev wind farm during the spring of 2004 (from CHRISTENSEN & HOUNISEN 2005).

In some of the flights across the transect lines the observers recorded the reaction of seabirds to the turbines. None of 13 divers and 28 Gannets entered the wind farm; all turned west and flew southwards again only after passing the wind farm. The same was observed for approaching Fulmars. A total of 28 Common Scoters did not fly into the wind farm, but detoured to the east or west. Common Scoters which were present in "many thousands" (spring of 2003) or "in large numbers" (spring of 2004) north and northwest of the wind farm avoided the turbines at a distance of 300-1000 m and often turned back when disturbed by ships. Short panic reactions during flights between the turbines were observed among Red-necked Grebes, Cormorants and one Great Black-backed Gull. In general, gulls, Arctic Skuas and Sandwich Terns seemed to enter the wind farm without fear, whereas Common/Arctic Terns often left the wind farm only a short time after entering it.

Table 6: Numbers of seabirds observed visually crossing four transect lines at the Horns Rev wind farm during the spring of 2003 and 2004 and the autumn of 2003; data from CHRISTENSEN *et al.* 2003, CHRISTENSEN & HOUNISEN 2004, 2005. For the direction of the transect lines, see Fig. 6. Birds crossing transect lines S and SW are considered to be flying within the wind farm (flying in or out, and flying inside, respectively).

	Spring				Autumn				Total	% S+SW (in wind farm)
	E	W	S	SW	E	W	S	SW		
Divers	28	3	0	0	39	14	0	0	84	0.0
Red-necked Grebe	0	0	0	0	6	0	0	0	6	
Fulmar	0	0	0	0	2	1	0	0	3	
Sooty Shearwater	0	0	0	0	1	0	0	0	1	
Storm Petrel	0	0	0	0	1	0	0	0	1	
Gannet	155	39	1	0	52	16	1	1	265	1.1
Cormorant	1	9	0	0	134	3	3	5	155	5.2
Shag	0	0	1	0	0	0	0	0	1	
Eider	0	0	2	0	5	0	0	0	7	
Common Scoter	36012	20786	114	522	558	334	6	2	58334	1,1
Velvet Scoter	160	0	0	0	0	2	1	0	163	0.6
Red-breasted Merganser	2	0	0	0	0	0	0	0	2	
Great Skua	0	0	0	0	2	0	0	0	2	
Arctic Skua	44	27	18	8	7	0	1	0	105	25.7
Common Gull	94	81	85	39	15	23	22	34	393	45.8
Herring Gull	148	221	122	83	183	80	95	67	999	36.7
Lesser Black-backed Gull	49	12	11	16	14	23	10	10	145	32.4
Great Black-backed Gull	80	63	31	20	237	201	139	121	892	34.9
Black-headed Gull	10	21	9	32	29	11	4	3	119	40.3
Little Gull	46	143	22	2	61	50	1	20	345	13.0
Sabine's Gull	0	0	0	0	1	0	0	0	1	
Kittiwake	78	141	46	29	61	93	12	33	441	24.3
Arctic/Common Tern	250	84	182	3	183	36	32	21	791	30.1
Sandwich Tern	545	938	1132	499	69	135	52	43	3413	50.6
Guillemot/Razorbill	6	1	0	0	37	7	1	1	53	3.8

In summary, some seabirds (divers, Gannet, scoters, auks) actively avoided the wind farm, suggesting the occurrence of a barrier effect during changes of location within an area of sea used by them. In the case of the Common Scoter, the observations in fact referred to local movements. A quite large proportion of gulls and especially terns entered the wind farm from the east and left it on the same side. As flights into and out of the wind farm were of the same magnitude, CHRISTENSEN *et al.* (2004) assume that these birds use the wind farm as a landmark on foraging flights starting at the coast.

### Coastal Wind Farms

Information from five coastal wind farms may help assess possible barrier effects from offshore wind farms for seabirds. Three of these wind farms are located directly at the shore on piers or seawalls (Blyth Harbour, Maasvlakte, Zeebrugge). One single turbine was built close to the IJsselmeer Dam (Den Oever) and one wind farm operates close to the shore in the IJsselmeer (Lely).

Nine turbines (rotor diameter 25 m, total height 38 m) were built at intervals of 200 m on the outer pier of **Blyth Harbour** in northeastern England. During a seven-year study

(STILL *et al.* 1996, PAINTER *et al.* 1999), considerable numbers of Cormorants, Eiders, Black-headed Gulls, Herring Gulls and Great Black-backed Gulls were present for several months or all year. When flying to and from their roosts in the harbour, Cormorants regularly crossed the row of turbines, with 10% of the birds flying at rotor height and all the others below it. During the first years of the study, some of the Eiders present outside the harbour flew into the harbour between the turbines, but later entered that area only by swimming. Large gulls made up 80% of all flights between the turbines, but many more flew along the row of turbines (20-300 flights per 10 min) than perpendicular to them (0.7-1.5 flights per 10 min). 16% (Great Black-backed Gulls) and 13% (Herring Gulls) of the crossings occurred at rotor height, but the greater share occurred below that height, and rarely above it. According to anecdotal reports, Fulmars, Black-headed Gulls, Kittiwakes and Sandwich Terns also passed through the wind farm.

Two rows of nine and 13 turbines, respectively, operate directly at or on the seawall of **Maasvlakte**, The Netherlands. The turbines (total height: 56.5 m, rotor diameter: 35 m) have been built at intervals of 130 m and are located between breeding colonies of gulls (mostly Lesser Black-backed and Herring Gulls, but also Black-headed and Common Gulls) and Common Terns and the offshore feeding grounds of these birds. In July 2001, VAN DEN BERGH *et al.* (2002) observed the flight activity of breeding seabirds in the wind farm. At both rows of turbines, most seabirds crossed below the rotor tips (92% and 62%, respectively). Of the birds passing below the rotor tip, 3.1% of gull flocks and 5.3% of Common Tern flocks showed behavioural reactions, but only one gull turned back. The rate of reaction was much the same amongst gulls flying above total turbine height (3.0%). The authors exclude a barrier effect for the foraging flights of the seabirds investigated and see their results as showing reduced sensitivity in breeding birds or rapid habituation during the breeding season.

A total of 23 turbines are in operation on the eastern pier of **Zeebrugge** harbour in Belgium. Turbine size varies: ten have a total height of 29 m (rotor diameter: 14 m), 12 a total height of 50 m (rotor diameter: 34 m), and one has a tip height of 79 m (rotor diameter: 48 m). Thirteen of the turbines are located directly at the shoreline, of which four are very close to a tern colony. The terns as well as gulls breeding elsewhere in the harbour regularly cross the wind farm in order to forage at sea (EVERAERT 2003). The majority of birds (54-82%) of all of the abundant species passed below rotor height and only a small fraction (1-14%) above total turbine height (Table 7). Depending on species and flight altitude, part of the passing seabirds showed avoidance reactions (deviations, changes of flight altitude, turning back) to the turbines (Table 7). Because most birds eventually passed the wind farm, a barrier effect was not assumed. The proportion of reacting birds was correlated with wing span, i.e. larger birds reacted in larger proportions (cf. Table 7).

Table 7: Proportions of seabirds showing avoidance reactions (deviation, change of flight altitude, turning back) when crossing the wind farm on the Oostdam of Zeebrugge harbour below rotor height (0-15 m), at rotor height (16-50 m) and above rotor height (51-65 m). The proportions referring to total turbine height (0-50 m) are given as well (all data from EVERAERT 2003).

Species	Flight altitude	N	Percentage of all birds passing	Number of birds showing reaction	Percentage of birds showing reaction
Herring Gull	0-15 m	85	62.5%	8	9.4%
	16-50 m	34	25.0%	13	38.2%
	51-65 m	17	12.5%	7	41.2%
	0-50 m	119	87.5%	21	17.6%
Lesser Black-backed Gull	0-15 m	44	54.3%	6	13.6%
	16-50 m	26	32.1%	7	26.9%
	51-65 m	11	13.6%	7	63.6%
	0-50 m	70	86.4%	13	18.6%
Black-headed Gull	0-50 m	15	88.2%	2	13.3%
Common Tern	0-15 m	408	81.9%	15	3.7%
	16-50 m	35	7.0%	11	31.4%
	51-65 m	55	11.0%	6	10.9%
	0-50 m	443	89.0%	26	5.9%
Little Tern	0-15 m	1010	54.3%	0	0.0%
	16-50 m	828	44.5%	4	0.5 %
	51-65 m	22	1.2%	1	4.5%
	0-50 m	1838	98.8%	4	0.2%

At the western end of the IJsselmeer dam, one 72 m high turbine with a rotor diameter of 44 m has been built in **Den Oever**, The Netherlands, exactly in the flight path of the morning and evening flights of Black Terns (according to a 1997 study, up to 15,000 birds) and Common Terns (1997: up to 6500 birds) in the post-breeding period. The results from the visual and radar observations showed that the terns deviated to both sides and kept a distance of 50-100 m from the turbine. Therefore, the direct vicinity of the turbine was used less than adjacent areas (DIRKSEN *et al.* 1998a).

The **Lely** wind farm, The Netherlands, consists of a row of four turbines (total height 60 m, rotor diameter 41 m) at intervals of 200 m. Because it is located 800 m offshore in the IJsselmeer, it is often referred to as a “semi-offshore wind farm”. The row of turbines intersects the flight paths of Pochards and Tufted Ducks during their flights between diurnal roosts and nocturnal feeding grounds. According to radar observations (DIRKSEN *et al.* 1998c), the behaviour of ducks during nocturnal flights differed between moonlit and dark nights. On moonlit nights, a higher proportion of ducks flew close to the wind farm. Moreover, flights between the turbines occurred; turning back did not. Nevertheless, the overall rate of flocks crossing was low, whereas detours were the common reaction to the wind farm. The authors assume that ducks can see the turbines (or perceive them in some way) on moonlit nights, but avoid approaches on dark nights by flying parallel to the wind farm. They further conclude that long-staying birds (in contrast to migrants stopping over) are habituated to the presence of turbines, even if they constitute a barrier to their regular movements. As during a second study with the same results 2500 Greater Scaups were present temporarily (DIRKSEN *et al.* 2000, VAN DER WINDEN *et al.* 2000), the conclusions seem to apply for this species as well.

### 5.1.2 Collision Risk to Flying Seabirds

While elaborate methods have been developed at onshore wind farms to extrapolate from casualties found near the turbines to the total number of birds collided (WINKELMAN 1992a, GRÜNKORN *et al.* 2005), it is impossible even to try to search for collision victims at sea. Real collision rates can therefore be obtained only by direct observation. With the exception of one pilot study, in which nocturnal bird flights are automatically recorded at a turbine at the Nysted wind farm (DESHOLM 2003), no such attempt has been made at offshore wind farms. Although evidence about collisions at offshore turbines is largely lacking, this question will be discussed with the help of observed behaviour of flying (mostly migrating) birds (see 5.1.1.) and by considering seabird species found as collision victims at coastal wind farms.

The only collision ever witnessed at an offshore wind farm happened at Yttre Stengrund: At dawn on 29 September 2003, the rear end of a flock of 310 Eiders migrating at an altitude of 60 m was hit by a rotor blade. One Eider fell into the water, and three others were forced to alight on the water, of which at least two managed to resume flight. In addition to this collision, five near-accidents were observed at the Utgrunden and Yttre Stengrund wind farms (PETTERSSON 2005). Extrapolating from the only observation of collision with a flock and including information on horizontal and vertical distribution of waterbird migration through the Kalmar Sound, PETTERSSON (2005) estimated the number of migrating waterbirds killed by collisions annually as 1-4 birds during the spring and ten birds during the autumn (i.e. 0.0002-0.0008% and 0.0016%, respectively, of all birds passing through the Kalmar Sound). The collision rate in spring may be twice as high because the fate of one of the four Eiders included in the accident was not clear.

#### 5.1.2.1 Seabird Collisions at Coastal Wind Farms

Some of the 35 seabird species regularly living in German marine areas (e.g. all tubenoses and auks) occur only rarely close to the coast. Hence, even studies at coastal wind farms cannot sufficiently establish the collision risk for seabirds at sea. However, some species do live in coastal areas, and for others, a comparison with closely related species may be of interest. Altogether, 13 seabird species were found to include collision victims at coastal wind turbines up to 4 km inland (Table 8). This does not exclude the possibility that further species are at risk of collision, but evidence is lacking so far. It is obvious that especially gulls are vulnerable to collisions.

Based on figures from the Netherlands, Belgium, Spain, Sweden, Austria, Britain, Denmark and Germany, HÖTKER *et al.* (2004) summarise the number of fatal seabird collisions as follows: Red-throated Diver (1), Cormorant (2), Black-headed Gull (87), Kittiwake (1), Common Gull (14), Herring Gull (189), Great Black-backed Gull (7), Common Tern (8), Guillemot (1). Since e.g. Fulmar and Eider are not included here, this compilation appears to be incomplete (cf. Table 8).

Table 8: Number of seabirds and related species found as collision victims at coastal wind farms. Species regularly occurring offshore in the German parts of North Sea and Baltic Sea are printed bold. Species belonging to the same systematic families are included for comparison. For Zeebrugge no numbers are reported. References: 1 BÖTTGER *et al.* 1990, 2 SCHERNER 1999, 3 WINKELMAN 1989, 4 MUSTERS *et al.* 1996, 5 WINKELMAN 1992a, 6 EVERAERT *et al.* 2002, 7 STILL *et al.* 1996, 8 PAINTER *et al.* 1999, 9 MEEK *et al.* 1993, 10 GRÜNKORN *et al.* 2005.

	Hookstel	Jadewindpark Wilhelmshaven	Bremerhaven-Fischereihafen	Nordholz	Westküste, Dithmarschen	Klärwerk Westerland Friedrich-Wilhelm-Lübke- Koog	Marienkoog	Reußenköge	Simonsberger Koog	Helgoland	Urk	Kreekrak	Oosterbierum	Oostdam Zeebrugge	Blyth Harbour	Burgar Hill
Reference	1	1	2	1	1	1	10	10	10	1	3	4	5	6	7,8	9
Country	D	D	D	D	D	D	D	D	D	D	NL	NL	NL	B	GB	GB
No. of turbines	1	3	2	25	32	1	13	15	17	13	1	25	5	18	23	9
Hub height (m)	27	60	32	20-22	15-23	24	?	?	?	?	50	30	30	35	22-55	25
Rotor diameter (m)	17	56	35	15-16	10-25	21	?	?	?	?	60	25	25	30	14-48	25
Distance to coast (km)	3	?	85	0,4	1	<1	2	1	1	2	<0.5	0.06	dike	3	dike	pier
<b>Red-throated Diver</b>			<b>1</b>													
<b>Fulmar</b>																<b>1</b>
<b>Cormorant</b>			<b>2</b>													<b>1</b>
Brent Goose												1				
Shelduck			1													
Gadwall												1				
Teal			1													
Mallard			2		2	2	2				2	2	2			
Shoveler											1					
Tufted Duck	1										1					
<b>Greater Scaup</b>											<b>1</b>					
<b>Eider</b>																<b>12</b>
<b>Common Gull</b>			<b>2</b>	<b>1</b>	<b>1</b>	<b>1</b>			<b>1</b>		<b>1</b>				x	
<b>Herring Gull</b>	<b>1</b>	<b>1</b>	<b>1</b>			<b>1</b>		<b>2</b>		<b>3</b>	<b>1</b>	<b>1</b>	<b>1</b>		x	<b>24</b>
<b>Lesser Black-b. Gull</b>															x	<b>1</b>
<b>Great Black-b. Gull</b>															x	<b>29</b>
<b>Black-headed Gull</b>	<b>1</b>		<b>2</b>		<b>1</b>	<b>1</b>	<b>1</b>		<b>2</b>		<b>4</b>	<b>1</b>	<b>2</b>		x	<b>4</b>
<b>Kittiwake</b>															x	<b>1</b>
<b>Black Tern</b>									<b>1</b>							
<b>Common Tern</b>																x
<b>Little Tern</b>																x
<b>Guillemot</b>			<b>1</b>													

Most of the studies at coastal wind farms listed in Table 8 give no information about the situation, in which collisions may have occurred. From gulls at Oosterbierum, it is known that both migration and flights to night roosts take place through the wind farm, including flights at rotor height (WINKELMAN 1992c). At Zeebrugge, it can be assumed that at least some of the seabirds that collided belonged to the local breeding populations and were hit during foraging flights. Eiders at Blyth Harbour collided when moving between the harbour and the adjacent sea across the pier through the row of turbines. No casualties were found after Eiders changed their mode of movement from flying to swimming. Other collisions victims like Cormorants and most of the gulls probably were also birds which roost regularly in the harbour.

At the Zeebrugge wind farm, the annual rate of fatal collisions in a ten-year study was calculated to range between 11 and 29 birds per turbine (EVERAERT *et al.* 2002). According to results from 2001, these rates mainly refer to seabirds, for in that year the total of 55 birds actually found included 44 gulls (mainly Herring Gulls, Lesser Black-backed Gulls, Great Black-backed Gulls and Kittiwakes) and five terns (three Common Terns and two Little Terns). The annual collision rate was higher along the turbine row perpendicular to the main flight direction of birds (22-58 collision victims per year and turbine), with a maximum of 120 collision victims per year at one turbine (EVERAERT *et al.* 2002). In September 2001, the rate of collisions per birds passing the turbines was investigated. For seabirds, the risk varied depending on flight altitude and time of day, and was highest for flights of Common Terns at rotor height (1:600, Table 9). At an inland wind farm (Boudewijn Canal), the overall collision risk for Herring Gulls was estimated to be 1:2200, but 1:750 if only flights at rotor height were considered (EVERAERT *et al.* 2002).

Table 9: Calculated collision risk per bird crossing the Zeebrugge wind farm at different times of day and flight altitudes in September 2001, based on the estimated number of collision victims and the observed number of passing birds (from EVERAERT *et al.* 2002).

	Flight altitude	Day and night	Day and night	Night	Night
		All altitudes	Rotor height	All altitudes	Rotor height
Gulls		1:3700	1:2100	1:1900	1:1000
Common Tern		1:3000	1:600	?	?
Little Tern		1:27,000	1:12,000	?	?

At a comparable wind farm on the pier of Blyth Harbour, the annual collision rate during a six-year study was six birds per year and turbine (corrected for recovery probability), of which 97% were seabirds (PAINTER *et al.* 1999). The annual additional mortality due to fatal collisions was 0.8% of the local wintering population of Eiders (up to 3200 birds) in the winter of 1992/93, 1.3% in 1993/94, 0.2% in 1994/95, 0.1% in 1995/96, 0% in 1996/97 and 0.1% in 1997/98 (STILL *et al.* 1996, PAINTER *et al.* 1999).



### 5.1.2.2 Flight Behaviour of Seabirds at Offshore Wind Farms

#### Tunø Knob, Denmark

A nocturnal radar study of staging Eiders and Common Scoters (December to April) showed both species with increased flight activity in the staging area on moonlit nights over dark nights. TULP *et al.* (1999) conclude that collision risk is reduced by relatively low flight activity on dark nights.

#### Utgrunden, Sweden

Visual and radar observations of migrating seabirds showed that in general the wind farm is detoured at daytime, at night and even during fog (PETTERSSON 2005). Only 0.3% of all diurnally migrating Eider flocks passed less than 200 m away from or less than 50 m above a turbine. In spring, only five of 20 flocks observed in the wind farm area passed at rotor height; all the other flocks were flying higher than 100 m or even above 200 m. Thus, the collision risk seems small for migrating Eiders; no collisions were recorded by visual observation. Radar observation showed flights through or above the wind farm occasionally occurring at night and during fog (PETTERSSON 2002), which could indicate a higher collision risk. If staging birds also avoid turbines, their collision risk would be equally low.

During spring migration, Eider flocks which did not start detours well in front of the wind farm but headed towards it, were tracked by optical rangefinder from 1 km in front of to 1 km behind the turbines (PETTERSSON 2005). These Eiders either flew around the turbines or passed between them. The distance kept from turbines was usually more than 200 m, and only four of 331 flocks tracked approached to about 100 m. Flights between turbines usually occurred when turbines were not operating. Comparing 1 km in front of and 1 km behind the wind farm, average flight altitude increased from 10-20 m to 30-40 m at 300 m in front of the turbines, to 30-50 m between the turbines, with some flocks flying at 150 m (PETTERSSON 2003, 2005). This behaviour near the turbines was modified by wind direction. This indicates that despite horizontal manoeuvres near the turbines, increased flight altitude brings more birds to the dangerous rotor height of approx. 30-100 m.

#### Yttre Stengrund, Sweden

Detours around the wind farm were common among migrating Eiders and other seabirds, both in spring and autumn, and daytime and nighttime, and also during fog (PETTERSSON 2002, 2003, 2005). Flight altitudes of autumn migrating Eiders measured by optical rangefinder were mostly below 20 m, but increased when approaching the wind farm. This was more pronounced when flying close to the wind farm, and those Eiders flying over the turbines did so well above rotor height (Fig. 8). Similar behaviour was exhibited by other seabirds (flight paths of Cormorants shown by PETTERSSON 2005). Migrating Common/Arctic Terns maintained their flight altitude of approximately 10 m, even when very close to the turbines, and flew along or between them. Therefore, terns were at much less danger from collision than Eiders, which increased their risk due to climbs to rotor height. However, as most seabirds fly around or over the wind farm (only 0.3% of all Eider flocks passed as close as 100 m from turbines), the collision risk seems to be low, at least during daytime (measurements of flight altitude are not available for nighttime), but the only collision ever witnessed at an offshore wind farm happened at Yttre Stengrund in daylight. If local movements of staging birds are similar in terms of distances from the turbines, collision risk would be low for them as well.

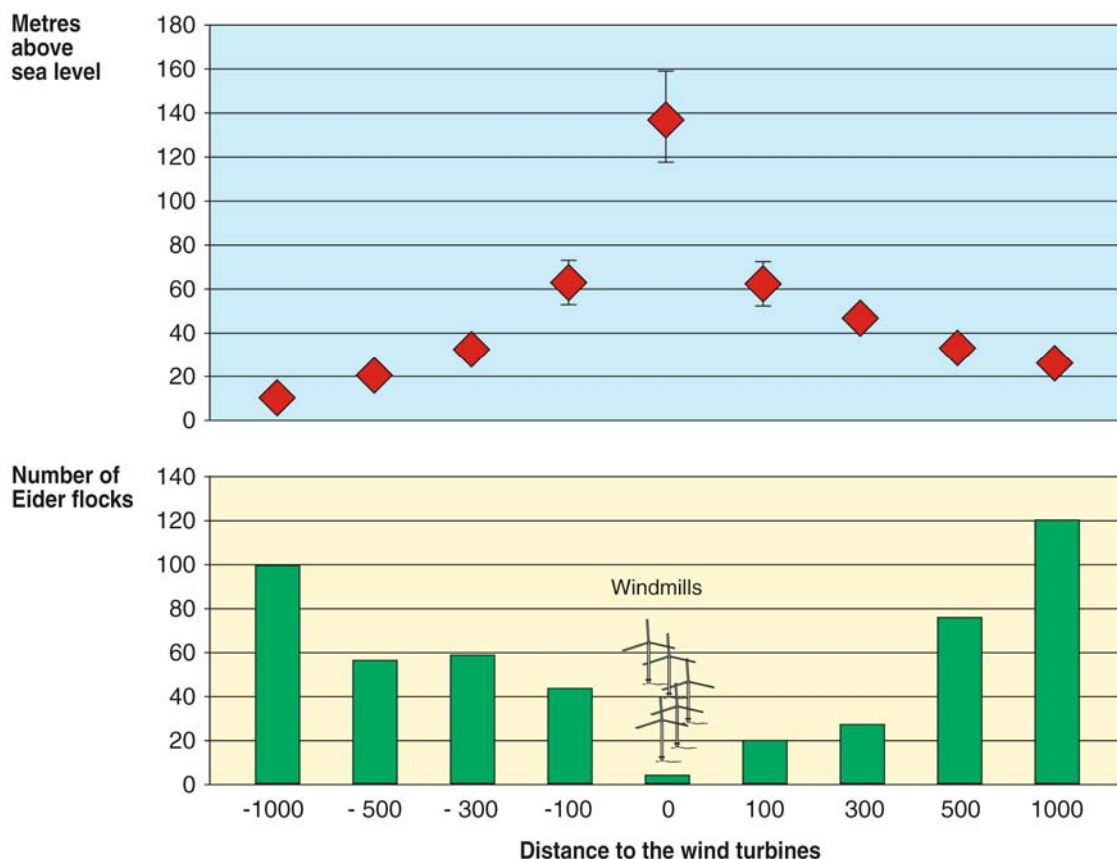

Fig. 8: Flight altitudes (top; mean and standard deviation) and number of flocks (bottom) recorded at various distances from Ytre Stengrund wind farm during autumn migration of Eiders (September 2002). Total turbine height is 96 m; from PETERSSON & STALIN 2002.

### Nysted, Denmark

Radar observations showed a high proportion of detours in the seabirds heading towards the wind farm during migration (KAHLERT *et al.* 2004a, 2004b, DESHOLM & KAHLERT 2005): in the autumn of 2003, only 13.8% (nighttime) and 4.5% (daytime) of all migrating flocks of Eiders and geese entered the wind farm, which substantially lowered the risk of collision. However, according to DESHOLM & KAHLERT (2005), a relatively large proportion of the entering flocks (6.5% at night, 12.3% in daytime) flew closer than 50 m to turbines (compared to the very low proportion in Kalmar Sound, with a minimum distance of 100 m there). Because the flight altitude in the wind farm area is not known, the risk cannot be quantified. Compared to the wind farms in Kalmar Sound (much lower proportions approaching the wind farms and a minimum distance of 100 m), the risk at Nysted appears to be high.

### Horns Rev, Denmark

Radar and visual observations revealed that detours were flown by seabirds migrating or moving locally (CHRISTENSEN *et al.* 2004, CHRISTENSEN & HOUNISEN 2004, 2005). Birds entering the wind farm changed their flight direction and adjusted their flight path parallel to the rows of turbines. This behaviour was more pronounced in daytime than at night, when flight paths were more likely to cross several rows of turbines, probably leading to higher collision risk. The same can be assumed during low visibility (e.g. fog), when detection of the turbines is probably reduced. Although some of the flight paths of

Common Scoters, gulls and terns shown in the figures by CHRISTENSEN & HOUNISEN (2005) pass quite close to turbines, it seemed that close proximity to the turbines was largely avoided, leading to lower general collision risk than with unaltered flights straight through the wind farm. Because the radar was oriented only horizontally, the birds tracked may also have crossed the wind farm above rotor height. The few published measurements of flight altitude at Horns Rev showed that all Cormorants and 61% of gulls, but only 9% of terns flew at rotor height (the remaining terns flew below rotor height, but the remaining gulls flew both lower and higher than rotor height). Hence, terns have lower collision risk than other birds which commonly fly between the turbines, such as gulls.

### 5.1.3 Habitat Loss for Seabirds

#### 5.1.3.1 Disturbance and Avoidance

Studies on possible habitat loss for seabirds caused by disturbance from offshore turbines and avoidance reactions were conducted at four wind farms in the Baltic Sea (Tunø Knob, Utgrunden, Yttre Stengrund, Nysted) and one in the North Sea (Horns Rev). They cover only part of the 35 seabird species regularly living in marine areas of Germany (Table 2). Notably little information is available for species usually living far offshore in the North Sea (such as Fulmar, Sooty Shearwater, skuas etc.).

#### Tunø Knob, Denmark

Possible habitat loss was investigated via three approaches: comparison of bird densities in the wind farm area with a reference area 14 km distant; distribution of birds within the wind farm area; and two experiments (unless otherwise stated, all information is from GUILLEMETTE *et al.* 1998). Basically, the study was designed as a BACI-study (before-after-control-impact, GREEN 1979), i.e. data were collected before and after construction in the impact area and in an unaffected reference area. Since no other species was sufficiently abundant, the study focused on Eiders (90% of staging birds) and in part on Common Scoters (8%). Bird data were collected only in winter (November to April). The data from the baseline study were even more limited, only covering the period from mid February to mid April.

Pre-construction aerial surveys in the whole Århus Bay revealed significant correlations between total number of Eiders and the subsamples at Tunø Knob (the 5000 ha wind farm area) and Ringebjerg Sand (the 4700 ha reference area). These correlations were maintained during operation, but in Tunø Knob, the regression curve flattened, i.e. the proportion of Eiders there decreased. This was confirmed by a 32% decrease in their total number, although the difference to numbers before construction was not significant. The relation between Eider numbers there and at Ringebjerg Sand remained unchanged. Counts from the ground verified the decline at Tunø Knob, while numbers in the reference area did not fall below the pre-construction level. The changes in Eider numbers were concomitant with a strongly fluctuating November supply of the size classes of blue mussels (*Mytilus edulis*) which are profitable prey for Eiders. These classes were lacking during the first two years of operation at Tunø Knob, which was probably the reason for the low numbers of Eiders. This was supported by the results from an additional study period in the third year of operation, when profitable size classes of mussels as well as large numbers of Eiders were present (GUILLEMETTE *et al.* 1999). Thus, the authors regard the fluctuating Eider numbers as a reaction to the

available food supply and classify it as natural variation. They conclude that spatial distribution was not affected by the wind turbines (GUILLEMETTE *et al.* 1998, 1999). The connection between food supply – the biomass of the bivalves *Cardium* spp. and *Spisula subtruncata* – and spatial distribution of Eiders was studied in greater detail the second year after the turbines were taken into operation, in four 200 x 200 m plots at distances of 0, 300, 320 and 600 m from the turbines. A strong correlation between bivalve biomass and Eider numbers was found. As these factors explained 93-98% of the variation, the impact of the turbines seemed negligible.

Within the four parts of the Tunø Knob area studied, Eider numbers showed a similar variation compared to the total wind farm area. During the baseline period, the four plots showed a stronger correlation with each other than during the first two years of operation. The authors conclude that this too is due to natural variation (GUILLEMETTE *et al.* 1998). On a smaller scale (1 ha plots), much variation occurred among seasons and years. Even a short time after the construction, Eiders were seen between the turbines. In the third year of operation, many Eiders were present in the wind farm, at less distance to the turbines than in the two preceding years, with a distribution much like that of the baseline year (GUILLEMETTE *et al.* 1999).

To investigate the effect of operation (motion, noise) on spatial distribution, Eiders were counted on successive days with moving and non-moving rotors, respectively. In the two observed zones, 200 m and 200-600 m around the wind farm, no significant difference was noted between operational and non-operational days. Not even the spatial distribution within the zones changed. When the rotors were turned on again, none of the ten Eider flocks observed (1-10 birds) took off, and their swimming movements varied: During the first 5 minutes, some approached to as close as 60 m, while others withdrew up to 35 m.

Decoy Eiders put out at different distances to the turbines were used to induce flying Eiders to land on the water. The attractive effect of the decoys increased with the distance to the turbines, i.e. fewer Eiders landed at 100 m distance than at 300 m and 500 m distance. This can be explained only in part by fewer Eiders flying close to the turbines.

Compared to the baseline year, Common Scoters sharply decreased at Tunø Knob in the first year of operation, nearly disappeared the second year, but were abundant the third year (GUILLEMETTE *et al.* 1999). In the Ringebjerg Sand reference area they initially stayed constant, but completely disappeared the second year. This shows that fluctuating numbers also occur in species other than Eider, but the role of wind farms remains unclear in this case. Cormorant droppings found on turbine foundations during a study of Eiders indicate that cormorants may rest on the foundations (TULP *et al.* 1999).

### **Utgrunden, Sweden**

In Kalmar Sound, staging and wintering birds were counted during construction and operation of the wind farm in two adjacent plots: one containing seven turbines (UT1, 60 km<sup>2</sup>, calculated from Fig. 3 in PETERSSON 2001) and the other serving as a non-manipulated reference area (UT2, 41 km<sup>2</sup>). Counts were conducted from the lighthouse in the middle of the Sound, but sometimes also from ships or aircraft. Before construction, birds were counted only twice (spring 1998, spring 1999; PETERSSON 2001), but results of both plots were lumped together and are given only for four species. Considerably more counts are available for the operational period and details

are given for nine species. Due to the lack of additional information needed for the interpretation of the spatial distribution (e.g. food supply, disturbance) and because natural fluctuation seems to occur in this part of the Kalmar Sound (PETTERSSON 2005), these data are hardly useful for the assessment of wind farm impacts. Furthermore, it must be considered that the wind farm consists only of a single row of turbines, probably limiting comparability to wind farms with several rows.

Staging and wintering birds were also counted from the lighthouse in parts of UT1 (UT10, in wind farm area) and UT2 (UT20, in reference area) in the spring seasons of 1999 (pre-construction) and 2001 (operation; PETTERSSON 2002). From 1999 to 2001, stocks of most species increased, but Long-tailed Ducks decreased to only about half of their former numbers (both in UT10 and UT20, Table 10). Bird numbers for UT10 and UT20 partially contradict the results reported from the same day for UT1 and UT2. For example, divers are completely absent in UT1, despite being mentioned as occurring in relatively high numbers in UT10, which is located within UT1. Such contradictions can also be found for counts in other seasons (again, especially for divers), for which no comparative data are available for the pre-construction period (PETTERSSON 2002). However, possible natural fluctuation prevents detection of wind farm impacts on bird numbers in this short-term study.

Table 10: Minimum and maximum numbers of seabirds counted in parts of the study plots UT1 and UT2 near the Utgrunden wind farm in the Kalmar Sound (from PETTERSSON 2002).

Study plot	UT10 (wind farm)	UT10 (wind farm)	UT20 (reference area)	UT20 (reference area)
Period	30 March – 2 April 1999 (pre-construction)	26 March – 4 April 2001 (operation)	30 March – 2 April 1999 (pre-construction)	26 March – 4 April 2001 (operation)
Number of counts	2	4	2	4
Divers	0-2	3-15	2-12	2-22
Cormorant	0-6	12-35	0	3-22
Eider	220-350	55-650	350-400	200-700
Long-tailed Duck	770-900	350-500	650-700	100-450
Common Scoter	15-70	0-12	0-45	0-10
Red-breasted Merganser	0-5	0-25	0	0-20

From the lighthouse, the observer mapped the exact locations of roosting and foraging Eiders and Long-tailed Ducks within UT10 and UT20. In the spring of 1999, positions were estimated according to the location of buoys, but in 2001, 2002 and 2003 a compass and rangefinder were used. Although the numbers partially changed, Long-tailed Ducks were seen in exactly the same places. Even foraging areas in close proximity to the turbines were retained, with Long-tailed Ducks diving less than 100 m from turbines and flying back and forth between them (PETTERSSON 2002, 2003, 2005). As in the pre-construction period, Eiders remained in the area north of the wind farm, but were seen at distances below 1 km from the northernmost turbine (PETTERSSON 2005). The same applies to Common Scoters, whereas flocks of Red-breasted Mergansers were also present south of the northernmost turbines and less than 1 km away from them (PETTERSSON 2005). Foraging Cormorants were also observed near turbines (PETTERSSON 2002).

At least in part, seabird distribution around the Utgrunden wind farm can be explained by food supply and disturbance caused by service boats (PETTERSSON 2005). Basic

investigations of blue mussels revealed high densities just north of the turbines and lower densities in the centre of the wind farm. Accordingly, their predators (staging Eiders and Long-tailed Ducks) concentrated in the area of high prey density north of the turbines. Observations of bird behaviour and the diurnal rhythm of abundance in the study plots showed that Long-tailed Ducks and Red-breasted Mergansers (and perhaps also Common Scoters, but not Eiders) were displaced by service boats operating in the wind farm. Individuals of the two species mentioned first returned to their foraging sites only 21-30 minutes after the service boat had left the area.

### Yttre Stengrund, Sweden

Aerial, ship-based and land-based surveys in the wind farm area were conducted ten times before construction and eighteen times during operation. A reference area was counted ten and twenty times, respectively (PETTERSSON 2005). As in the parallel study at Utgrunden, the significance of the data for ten species is limited. Again, the lack of information on biotic and abiotic factors other than wind turbines prevents the detection of wind farm effects on seabird numbers. Also, the presence of only one turbine row restricts extrapolation of the results to larger wind farms.

### Nysted, Denmark

Aerial surveys along transects were used to describe the spatial distribution of staging and wintering birds in a 1350 km<sup>2</sup> large area of the Baltic Sea south of the islands Lolland and Falster. Twenty surveys took place before the construction of the wind farm (August 1999 to March 2002), four during construction (August 2002, January, March and April 2003; Kahlert *et al.* 2004b) and five during operation (December 2003, January, 2x March, April 2004; PETERSEN 2004).

Based on the bird densities in the total study area, avoidance or preference was investigated by using the selectivity index of JACOBS (1974) for three areas: the wind farm (WF, approx. 23 km<sup>2</sup>), the wind farm plus a 2 km zone around it (WF+2-zone) and the wind farm plus a 4 km zone around it (WF+4-zone). To date, selectivity indices for pre-construction, construction and operational periods for March and April have been compared, both for numbers of individuals and numbers of flocks. Most seabird species only occur in shallow waters near the coast, and only three species proved to be abundant in the wind farm area and its surroundings. The three periods are compared only for those species.

Before construction, **Eiders** avoided the wind farm area, but in the WF+2 and WF+4 zones, their density resembled that of the total area (Table 11). During construction, the wind farm was abandoned completely, and index values became negative in the zones around it. Compared to the total study area, the wind farm was still mostly avoided during operation (in total 16 birds in three surveys), and in the surrounding the index values further declined (Tables 11 and 12). Derived from data given by KAHLERT *et al.* (2004b) and PETERSEN (2004), during operation the relative number of Eiders increased by 48% compared to the situation before construction in the wind farm, but decreased by 88% in the WF+2 zone and 44% in the WF+4 zone (Table 13).

Table 11: Selectivity index D (after JACOBS 1974) of seabirds in the Nysted wind farm and the 2 km and 4 km buffer zones, during the baseline period (4 April and 26 April 2000, 16 March and 20 April 2001, 26 March 2002), during construction (4 March and 24 April 2004) and during operation (5 March, 24 March and 15 April 2004). Positive values (maximum +1) indicate preference and negative ones (minimum -1) avoidance of the tested area compared to the whole study area (0: bird density in tested area is equal to whole study area). Taken from KAHLERT *et al.* 2004b and PETERSEN 2004 (levels of significance are not given).

		Bird numbers				Flock numbers			
		WF	WF+2	WF+4	n	WF	WF+2	WF+4	n
		D	D	D		D	D	D	
Eider	baseline	-0.81	-0.13	0.04	21020	-0.14	0.13	0.24	1154
	construction	-1.00	-0.58	-0.16	2573	-1.00	-0.24	-0.07	282
	operation	-0.73	-0.77	-0.42	5116	-0.16	-0.25	-0.01	552
Long-tailed Duck	baseline	0.46	0.46	0.40	5966	0.64	0.68	0.65	939
	construction	-0.91	-0.13	-0.10	1794	-0.64	0.13	0.24	399
	operation	-0.20	-0.12	-0.09	4474	0.29	0.35	0.29	782
Herring Gull	baseline	-0.64	-0.65	-0.38	4779	-0.29	-0.28	-0.15	1416
	construction	-0.52	-0.66	-0.05	824	-0.21	-0.40	-0.26	403
	operation	-0.71	-0.78	-0.75	9428	-0.14	-0.24	-0.33	1655

Table 12: Changes in selectivity index D (bird numbers) for seabirds at the Nysted wind farm, and in the 2 km and 4 km buffer zones, from the baseline period to the construction and operational periods, (calculated from KAHLERT *et al.* 2004b and PETERSEN 2004; levels of significance are not given).

	construction			operation		
	WF	WF+2	WF+4	WF	WF+2	WF+4
Eider	-0.19	-0.45	-0.20	+0.08	-0.64	-0.46
Long-tailed Duck	-1.37	-0.59	-0.50	-0.66	-0.58	-0.49
Herring Gull	+0.12	-0.01	+0.33	-0.07	-0.13	-0.37

Table 13: Proportion of seabirds present in the Nysted wind farm (WF) and the 2 km and 4 km buffer zones, during the operational period compared to the baseline period (calculated from KAHLERT *et al.* 2004b and PETERSEN 2004).

	WF	0-2 km distance	2-4 km distance
Eider	+48.0%	-87.8%	-45.2%
Long-tailed Duck	-74.4%	-65.0%	-41.6%
Herring Gull	-22.1%	-47.9%	-75.2%

For **Long-tailed Ducks**, the wind farm and its surrounding area were among the clearly preferred areas south of Lolland and Falster islands. During construction, the wind farm was almost completely avoided, and the surrounding zones were distinctly less attractive (Table 11). Considering numbers of birds, selectivity indices were still low during operation, but increased slightly compared with the construction period. However, the whole area seemed to be avoided. Considering flocks, the wind farm and surrounding zones belonged to the preferred areas within the whole study area, but

these also showed lower selectivity indices than in the baseline years. From pre-construction to operation, bird numbers decreased by 74% in the wind farm, by 65% in the 0-2 km zone and by 42% in the 2-4 km zone (Table 13). When plotting the numbers of Long-tailed Ducks within 4 km against their distance from the wind farm, the curve is flattest in the year of construction (2003); in the operational period (2004), it resembles those of the three pre-construction years. Hence, avoidance of the wind farm was greatest during construction and was within the natural range during operation. The three spring surveys during the operational period recorded a total of 60 Long-tailed Ducks in the wind farm.

During all periods, **Herring Gulls** visited the wind farm and its surrounding area in lesser densities than in the total study area. Based on bird numbers, this avoidance was strongest during operation and weakest in the baseline period. However, the differences were small compared to the two duck species. A similar result was obtained for the number of flocks, but the avoidance of the wind farm was more pronounced before construction than afterwards. (Table 11). Compared to the pre-construction period, Herring Gulls decreased by 22% (WF), 48% (0-2 km zone) and 75% (2-4 km zone) during operation (Table 13). A total of 32 Herring Gulls was counted within the wind farm during the three spring surveys. It is worth noting that the distribution of Herring Gulls in the study area is strongly influenced by the distribution of active fishing vessels (KAHLERT *et al.* 2004b).

Anecdotal information is available for other seabirds, which are less abundant in the wind farm area (KAHLERT *et al.* 2004a, 2004b, PETERSEN 2004). All divers observed during construction were at least 1400 m away from the turbines. During operation, one diver was seen inside and another 200 m outside the wind farm. The study area was visited by only a few **Common Scoters** (maximum number: 133 birds). During the surveys, a flock of 12 birds was seen within the wind farm (construction). A total of 14 **Red-breasted Mergansers** was observed within or close to the wind farm during operation. During radar observation of bird movements, three large flocks of foraging **Cormorants** (1500, 2150 and 3700 birds) were detected within the wind farm or less than 1 km away. Workers reported that Cormorants were diving in the wind farm area and resting on the foundations.

### **Horns Rev, Denmark**

With the same methods and by the same researchers as in the Nysted wind farm, the spatial distribution of seabirds in the Horns Rev area was monitored by aerial surveys. The study area of 1846 km<sup>2</sup> extends to the Danish coastline from Blåvandshuk to Fanø. Sixteen surveys were conducted during the baseline period (April 1999 to August 2001), five during construction (September 2001 to August 2002; CHRISTENSEN *et al.* 2003), and ten (to date) during operation (February to December 2003, PETERSEN *et al.* 2004; February to September 2004, PETERSEN 2005). As two surveys (7 January and 12 March 2002) took place during the construction period, but at times with no turbines built and no construction in progress (see CHRISTENSEN *et al.* 2003), it seems that they were later on treated as baseline data, while the first two surveys (20 April and 4 May 1999) were no longer considered in the most recent reports (PETERSEN *et al.* 2004, PETERSEN 2005).

In relation to the bird density in the total study area, avoidance and preference of three areas was identified by means of the selectivity index of JACOBS (1974): the wind farm itself (approx. 20 km<sup>2</sup>), the wind farm plus 2 km around it (WF+2-zone) and the wind farm plus 4 km around it (WF+4-zone). The indices were compared for all months,



grouped into pre-construction, construction and operational periods for both the number of individuals and the number of flocks (CHRISTENSEN *et al.* 2003, PETERSEN *et al.* 2004). Most recently, the same approach was used for the spring season (February to May) only, but including two years of operation (PETERSEN 2005). Therefore, post-construction results are presented two-fold, for the whole year and for spring only. No survey results have been reported from the period when the rotors were taken down temporarily due to technical problems (summer and autumn 2004). The procedure outlined above was applied only to species regularly occurring in the offshore parts of the study area, but not for species restricted to coastal areas. Bird numbers in the wind farm and the zones around it were tested for significant differences between the two baseline years (1999 and 2000) and the construction period. Such a test was not applied during the operational period.

In the baseline period, divers were present in the wind farm area in approximately the same density as in the total study area, and in the WF+2- and WF+4-zones densities were only slightly lower. In contrast to this, these areas were strongly avoided in the construction period and nearly completely abandoned during operation (with no birds within the wind farm area itself; Table 14 and 15). The decline in the wind farm during construction is not significant, because only a single diver was observed, which was in fact 2.5 km away from the only active ship (at that time no turbine had been built). However, when including the surrounding zones, the decline is significant. During heavy construction work in April 2002, no diver came closer than 2 km to the wind farm area. Compared to the baseline period, divers decreased by 100% (wind farm), 97% (0-2 km distance from WF) and 77% (2-4 km distance from WF) during the operational period (Table 17). Visual observations of flying birds once revealed a diver foraging at the edge of the operating wind farm, and several others at distances of 100-800 m from the next turbine (CHRISTENSEN *et al.* 2004).

**Gannets** were never recorded in the wind farm area (even during the baseline period), but when the surrounding zones are included, the selectivity indices declined from the baseline to the operational period (Table 14). Furthermore, many fewer Gannets were observed there during operation than expected from the baseline surveys (Table 17). Aerial surveys revealed no **Cormorants** in the wind farm. Changes in the selectivity indices (Tables 14 and 16) can be explained by a single observation of a Cormorant during the baseline period in the WF+4-zone, while the only Cormorant seen during the operational period was in the WF+2-zone. During visual observations from the transformer station, a Cormorant was once seen resting on the fence of a foundation of a turbine with rotating blades (CHRISTENSEN *et al.* 2004). During the spring of 2004, a number of observations referred to 2-3 **Shags** resting on the meteorological mast east of the wind farm, and at least one bird foraged between the turbines (CHRISTENSEN & HOUNISEN 2004).

**Eiders** were among the three most abundant species in the study area, but were concentrated close to the coast and usually did not occur in the wind farm and surrounding areas (Table 14). Inside the wind farm, only one Eider was seen during the baseline surveys; none were recorded during operation.

With up to 381,000 individuals (March 2003), **Common Scoters** were by far the most abundant seabirds in the total study area, but numbers and distribution varied greatly among the years studied. Compared to the total study area, the wind farm area and WF+2-zone appeared to be avoided during the pre-construction period, but the large numbers of Common Scoters in the WF+4-zone resulted in a nearly balanced D-value (Table 14). During construction, the proportions of Common Scoters in the wind farm and WF+2-zone increased (Tables 14 and 16). However, the increase compared to the

first baseline year was significant as was the decrease compared to the second baseline year. During operation, the wind farm and the WF+2-zone were completely abandoned and the WF+4-zone was strongly avoided (Table 14). This avoidance was less pronounced when including data from the spring of 2004 (Table 15), as large numbers were present in the vicinity of the northwestern corner of the wind farm at that time. That Common Scoters usually do not forage or rest between the turbines may at least in part be due to reluctance to fly into the wind farm. In a sample of 96 flocks approaching the wind farm in the spring of 2004, 76 landed on the water (mostly more than 500 m from the nearest turbine); the remaining 20 flocks changed flight direction (CHRISTENSEN & HOUNISEN 2005).

**Arctic Skuas** were not seen in any considerable numbers during the aerial surveys, but some of them were observed within the wind farm from the transformer station (CHRISTENSEN *et al.* 2003, Table 6). As they seemed to be attracted by gulls, these birds can be regarded as foraging birds and therefore fall into the category of species which do not generally avoid wind farms.

On the basis of their presence in the entire study area, **Herring Gulls** avoided the wind farm area in the baseline period, but were more abundant there during operation and especially during construction (Tables 14, 15 and 16, significant increase for the construction period). The authors attribute this shift to the attractive effect of ship traffic. In addition, the foundations may have been used for resting. The latter was noted four times during systematic observations from the transformer station (once at an operating turbine, CHRISTENSEN *et al.* 2004).

Changing preferences were even more pronounced in **Great Black-backed Gulls**, which initially strongly avoided the wind farm and its surroundings (baseline period), but obviously preferred this area during operation (Tables 14 and 16). The situation was not so clear during the construction period (strong avoidance of the wind farm, but increased selectivity indices in the surrounding zones plus the wind farm, Table 14). Systematic observations from the transformer station showed Great Black-backed Gulls eight times resting on turbines, three of which were operating (CHRISTENSEN *et al.* 2004).

In the total study area, numbers of **Little Gulls** showed great variability between years. They avoided the wind farm area before and especially during construction. By contrast, the area was clearly preferred during the operational period (Tables 14 and 16). Considering only spring data (2003 and 2004), the wind farm itself was still avoided (Table 15). During the survey in December 2003, the majority of the Little Gulls observed were foraging between the turbines.

Many **Kittiwakes** were present in the study area in the baseline and construction periods, but the wind farm area and zones around it were avoided (more so during the construction period than during the baseline period, Table 14). This decrease was significant only in the WF+2 and WF+4 zones. In the first year of operation, the species occurred in much lower numbers in the study area as a whole. Eight birds were seen within the wind farm area and another three in the surrounding zones, but due to the low total number, the increased D-values (Table 14) have low significance. Including data from the second year of operation (2004), the wind farm is still an avoided area, whereas this effect seems to be less pronounced in the surrounding zones (Table 15). Without giving more details, CHRISTENSEN *et al.* (2004) mention that Kittiwakes were observed resting on fences of the turbine foundations.

Table 14: Selectivity index D (from JACOBS 1974) of seabirds in the Horns Rev wind farm and the 2 km and 4 km buffer zones, during the baseline (August 1999 to March 2002), construction (September 2001 to August 2002) and operational periods (February to December 2003). Data obtained from the entire year. Positive values (maximum +1) indicate preference and negative values (minimum -1) avoidance of the tested area compared to the entire study area (0: bird density in tested area equals that of entire study area). Values are printed bold if based on significantly different proportions ( $\chi^2$  tests). Note that the counts on 7 January and 12 March 2002 are included in both the baseline and the construction period because of different classification in CHRISTENSEN *et al.* (2003) and PETERSEN *et al.* (2004).

		Bird numbers				Flock numbers			
		WF	WF+2	WF+4	n	WF	WF+2	WF+4	n
		D	D	D		D	D	D	
Divers	baseline	0.00	-0.01	<b>-0.13</b>	1331	0.10	0.02	-0.10	926
	construction	-0.66	<b>-0.78</b>	<b>-0.46</b>	322				
	operation	<b>-1.00</b>	<b>-0.96</b>	<b>-0.87</b>	1036	<b>-1.00</b>	<b>-0.93</b>	<b>-0.76</b>	548
Gannet	baseline	<b>-1.00</b>	<b>-0.45</b>	-0.02	515	-1.00	-0.27	-0.15	241
	construction								
	operation	-1.00	<b>-0.77</b>	<b>-0.68</b>	149	-1.00	-0.68	<b>-0.57</b>	103
Cormorant	baseline	-1.00	<b>-1.00</b>	<b>-0.90</b>	168	-1.00	-1.00	-0.65	45
	construction								
	operation	-1.00	-0.57	<b>-0.77</b>	73	-1.00	0.37	0.01	10
Eider	baseline	<b>-0.99</b>	<b>-1.00</b>	<b>-1.00</b>	12,600	<b>-0.81</b>	<b>-0.94</b>	<b>-0.94</b>	593
	construction	<b>-1.00</b>	<b>-1.00</b>	-1.00	1349				
	operation	<b>-1.00</b>	<b>-0.98</b>	<b>-0.96</b>	5018	<b>-1.00</b>	<b>-0.91</b>	<b>-0.83</b>	396
Common Scoter	baseline	<b>-0.60</b>	<b>-0.35</b>	<b>-0.07</b>	128,786	<b>-0.73</b>	<b>-0.61</b>	<b>-0.45</b>	3977
	construction	<b>-0.33</b>	<b>-0.21</b>	<b>-0.33</b>	49,823				
	operation	<b>-1.00</b>	<b>-1.00</b>	<b>-0.87</b>	574,988	<b>-1.00</b>	<b>-0.98</b>	<b>-0.80</b>	3792
Herring Gull	baseline	<b>-0.93</b>	<b>-0.86</b>	<b>-0.76</b>	18,005	<b>-0.75</b>	<b>-0.63</b>	<b>-0.48</b>	3828
	construction	<b>-0.47</b>	<b>0.12</b>	<b>0.25</b>	4131				
	operation	<b>-0.65</b>	<b>-0.57</b>	<b>-0.53</b>	11,064	0.04	-0.01	0.03	1753
Great Black-backed Gull	baseline	<b>-0.80</b>	<b>-0.56</b>	<b>-0.43</b>	556	<b>-0.74</b>	<b>-0.45</b>	<b>-0.37</b>	417
	construction	-1.00	-0.29	0.03	108				
	operation	<b>0.62</b>	<b>0.44</b>	<b>0.45</b>	95	0.50	0.33	<b>0.41</b>	87
Little Gull	baseline	-0.34	-0.23	-0.12	127	-0.22	-0.09	0.03	97
	construction	-1.00	<b>-0.66</b>	<b>-0.45</b>	286				
	operation	<b>0.46</b>	<b>0.40</b>	<b>0.37</b>	822	0.31	<b>0.37</b>	<b>0.44</b>	410
Kittiwake	baseline	<b>-0.34</b>	<b>-0.30</b>	<b>-0.22</b>	2520	-0.24	-0.13	0.03	1118
	construction	<b>-0.56</b>	<b>-0.80</b>	<b>-0.64</b>	700				
	operation	<b>0.65</b>	<b>0.20</b>	0.00	113	-0.04	-0.55	-0.27	68
Arctic/Common Tern	baseline	<b>-0.23</b>	<b>-0.41</b>	<b>-0.28</b>	2400	-0.05	<b>-0.20</b>	-0.07	1042
	construction								
	operation	<b>-1.00</b>	<b>0.33</b>	<b>0.21</b>	378	-1.00	0.23	0.20	185
Guillemot/Razorbill	baseline	-0.28	<b>-0.32</b>	<b>-0.13</b>	1104	-0.15	-0.17	-0.07	590
	construction	-1.00	<b>-1.00</b>	<b>-1.00</b>	207				
	operation	<b>-1.00</b>	<b>-0.55</b>	<b>-0.44</b>	415	-1.00	-0.38	<b>-0.32</b>	224

Table 15: Selectivity index D (after JACOBS 1974) of seabirds in the Horns Rev wind farm (WF) and the 2 km and 4 km buffer zones, during the baseline period (seven surveys 2000 to 2001) and during operation (six surveys 2003 and 2004). Only spring data (February to May) are considered (after PETERSEN 2005). Note that baseline values are different from Table 14, because they are based on a different selection of surveys. Positive values (maximum +1) indicate preference and negative ones (minimum -1) avoidance of the tested area compared to the whole study area (0: bird density in tested area is equal to whole study area). Values are printed bold if based on significantly different proportions ( $\chi^2$  tests).

		bird numbers				flock numbers			
		WF	WF+2	WF+4	n	WF	WF+2	WF+4	n
		D	D	D		D	D	D	
Divers	baseline	-0.01	0.02	<b>-0.16</b>	1106	0.10	0.04	-0.13	734
	operation	<b>-1.00</b>	<b>-0.95</b>	<b>-0.81</b>	1611	<b>-1.00</b>	<b>-0.91</b>	<b>-0.69</b>	924
Gannet	baseline	-1.00	-1.00	<b>-0.77</b>	74	-1.00	-1.00	-0.59	38
	operation	<b>-1.00</b>	<b>-1.00</b>	<b>-0.87</b>	450	-1.00	<b>-1.00</b>	<b>-0.73</b>	134
Eider	baseline	<b>-0.99</b>	<b>-1.00</b>	<b>-0.99</b>	9168	-0.69	<b>-0.89</b>	<b>-0.89</b>	345
	operation	<b>-1.00</b>	<b>-0.96</b>	<b>-0.94</b>	4730	<b>-1.00</b>	<b>-0.67</b>	<b>-0.68</b>	334
Common Scoter	baseline	<b>-0.38</b>	<b>-0.06</b>	<b>0.26</b>	71,978	<b>-0.45</b>	<b>-0.16</b>	0.06	1327
	operation	<b>-0.93</b>	<b>-0.56</b>	<b>-0.58</b>	578,233	<b>-0.57</b>	-0.03	<b>-0.15</b>	4885
Herring Gull	baseline	<b>-0.94</b>	<b>-0.88</b>	<b>-0.81</b>	13,027	<b>-0.66</b>	<b>-0.63</b>	<b>-0.41</b>	1529
	operation	<b>-0.74</b>	<b>-0.61</b>	<b>-0.59</b>	13,298	0.04	-0.04	0.00	1680
Little Gull	baseline	-1.00	-1.00	-0.30	37	-1.00	-1.00	0.06	19
	operation	<b>-0.71</b>	<b>0.24</b>	<b>0.27</b>	826	-0.48	<b>0.25</b>	<b>0.35</b>	394
Kittiwake	baseline	-0.63	-0.27	-0.11	283	-0.38	-0.16	0.02	141
	operation	<b>-1.00</b>	0.06	<b>-0.25</b>	366	-1.00	-0.25	-0.39	148
Arctic/Common Tern	baseline	-0.21	<b>-0.35</b>	<b>-0.31</b>	586	-0.01	-0.17	-0.07	261
	operation	<b>-1.00</b>	0.14	<b>0.16</b>	575	-1.00	-0.04	-0.07	295
Guillemot/Razorbill	baseline	-0.07	-0.08	<b>-0.33</b>	219	-0.12	-0.14	-0.34	164
	operation	-1.00	<b>-0.65</b>	<b>-0.66</b>	309	-1.00	<b>-0.61</b>	<b>-0.62</b>	182

Table 16: Changes in selectivity index D (bird numbers) for seabirds in Horns Rev wind farm (WF) as well as including 2 km and 4 km buffer zones from the baseline period to the construction and operation period, respectively (calculated from CHRISTENSEN *et al.* 2003, PETERSEN *et al.* 2004 and PETERSEN 2005). Values are printed bold if derived from pairs of D-values, which both are based on significantly different proportions ( $\chi^2$  tests). Discrepancies to Table 14 are owing to different classifications of two counts (7 January and 12 March 2003) by the two authors.

	Construction (all year, 2001-2002)			Operation (all year, 2003 only)			Operation (spring only, 2003-2004)		
	WF	WF+2 km	WF+4 km	WF	WF+2 km	WF+4 km	WF	WF+2 km	WF+4 km
Divers	-0.66	-0.79	<b>-0.29</b>	-1.00	-0.95	<b>-0.74</b>	-0.99	-0.97	<b>-0.65</b>
Gannet				-	<b>-0.32</b>	-0.66	0.00	0.00	<b>-0.10</b>
Cormorant				-	+0.43	<b>+0.13</b>			
Eider	<b>-0.01</b>	<b>0.00</b>	0.00	<b>-0.01</b>	<b>+0.02</b>	<b>+0.04</b>	<b>-0.01</b>	<b>+0.04</b>	<b>+0.05</b>
Common Scoter	<b>+0.17</b>	<b>-0.01</b>	<b>-0.40</b>	<b>-0.40</b>	<b>-0.65</b>	<b>-0.80</b>	<b>-0.55</b>	<b>-0.50</b>	<b>-0.32</b>
Herring Gull	<b>+0.47</b>	<b>+1.00</b>	<b>+0.99</b>	<b>+0.28</b>	<b>+0.29</b>	<b>+0.23</b>	<b>+0.20</b>	<b>+0.27</b>	<b>+0.22</b>
Great Black-backed Gull	0.00	+0.26	+0.52	<b>+1.42</b>	<b>+1.00</b>	<b>+0.88</b>			
Little Gull	0.00	-0.22	-0.19	+0.80	+0.63	+0.49	+0.29	+1.24	+0.57
Kittiwake	<b>-0.18</b>	<b>-0.55</b>	<b>-0.49</b>	<b>+0.99</b>	+0.50	+0.22	-0.37	+0.33	-0.14
Common/Arctic Tern				<b>-0.77</b>	<b>+0.74</b>	<b>+0.49</b>	-0.79	+0.49	<b>+0.47</b>
Guillemot/Razorbill	-0.77	<b>-0.70</b>	<b>-0.96</b>	-0.72	<b>-0.23</b>	<b>-0.31</b>	-0.93	-0.57	<b>-0.33</b>

The wind farm and its surrounding were avoided by **Common and Arctic Terns** before construction. During operation, the zones around the wind farm became preferred areas, whereas no tern had been seen within the wind farm during the aerial surveys (Tables 14, 15 and 17). However, as the terns observed in the operational period were aggregated into a few flocks, the significance of these data appears to be low. Without giving more details CHRISTENSEN *et al.* (2004) report that Common/Arctic Terns were seen resting on fences of the turbine foundations.

**Guillemots and Razorbills** were already underrepresented in the wind farm and the surrounding area during the baseline surveys, but they completely avoided this area during construction (no auk occurred within 4 km of the wind farm, see Table 14; significant decrease). In the operational period auks kept away from the wind farm as well. In the WF+2 and WF+4 zones, the selectivity indices decreased compared to the baseline period, with auks occurring 14% and 49%, respectively, less than expected in the zones around the wind farm (Table 14, 15, 16 and 17).

In summary, it was shown that during the baseline years the wind farm and its surrounding area did not belong to the preferred sites within the study area as a whole for most species. Only Common Scoters were present in the WF+2- and WF+4-zones in densities above average. Divers, Common/Arctic Terns and Guillemots/Razorbills occurred in more or less expected densities. During construction, most species (divers, Great Black-backed Gull, Little Gull, Kittiwake, Guillemot/Razorbill) avoided the wind farm area; to some extent, this also applies to the surrounding zones. Common Scoters and especially Herring Gulls increased during this period. From the fact that in most species (except Kittiwakes) decreases in the construction period were based on non-significant D-values in the baseline period and that changes of the D-values were more pronounced in the surrounding zones than in the wind farm itself, CHRISTENSEN *et al.* (2003) conclude that an effect of the turbines and/or construction cannot be verified. Low sample sizes limited the possibility of direct comparison between bird numbers in the wind farm down to five species/groups. A significant decline was found only in auks, whereas Herring Gulls increased significantly; Common Scoters increased or decreased significantly, depending on which baseline year is chosen. Changes of diver and Kittiwake numbers were not significant.

Tab. 17: Proportion of seabirds present in the Horns Rev wind farm (WF) and in the 0-2 km and the 2-4 km zones during the operational period, compared with the baseline period (calculated from PETERSEN *et al.* 2004).

	WF	0-2 km zone	2-4 km zone
Divers	-100.0%	-96.8%	-77.0%
Gannet	-	-65.0%	-82.4%
Common Scoter	-100.0%	-100.0%	-88.0%
Herring Gull	+470.3%	+223.8%	+71.6%
Great Black-backed Gull	+3433.3%	+324.0%	+287.1%
Little Gull	+427.4%	+177.6%	+78.8%
Kittiwake	+801.9%	-100.0%	-31.1%
Common/Arctic Tern	-100.0%	+737.2%	+37.8%
Guillemot/Razorbill	-100.0%	-14.1%	-49.0%

During the operational period, divers, Common Scoters, Common/Arctic Terns and Guillemots/Razorbills did not occur in the wind farm at all, and except for the terns, they also declined in the zones to 4 km. Compared to the baseline period, Herring Gulls showed reduced avoidance of the wind farm. Great Black-backed Gulls avoided the wind farm before construction, but preferred it during operation. The same was true for Little Gulls over the entire year, but not for the spring. Changed preference was also observed for Common/Arctic Terns, but only in the surrounding zones. From notes by CHRISTENSEN *et al.* (2004) it appears that birds only rarely use the foundations for resting, and then mostly at the edge of the wind farm and when the rotors are not moving.

The authors of the reports (last by PETERSEN 2005) stressed that avoidance should not only be attributed to the physical presence of the turbines, but possibly also to service boat traffic (on approx. 150 days per year).

### 5.1.3.2 Habitat Alteration

Since offshore wind farms are commonly built on soft substrate, the construction of turbines introduces a new type of habitat for benthic organisms. The settlement of sessile invertebrates and algae as well as the subsequent attraction of mobile invertebrates and fish are known as the “reef effect”. It was argued that seabirds may benefit from this increase in biomass, especially if fish stocks increase because of the absence of fisheries (PERCIVAL 2001). Results from studies at operating wind farms – even if only very preliminary – confirmed the assumed development of hard bottom communities, but their utilisation by seabirds remains to be proven. Physical habitat loss, i.e. the replacement of soft by hard substrate, can be regarded as being of little significance. The area of soft bottom and the respective amount of infauna lost is far below 1% in large wind farms and thus seems to be negligible. Initial results from Horns Rev also indicate that the benthic community and sandeels (an important prey species for seabirds) are not negatively affected.

#### **Svante, Sweden**

Fish studies were conducted at this single wind turbine, which was built 250 m offshore at Nordersund in southeastern Sweden in 1990. In up to 200 m distance from the turbine, more fish were caught when the rotor did not move compared to periods of operation. However, it remained unclear whether this was due to the fact that the catchability of the fish was being measured, or because fish were attracted during non-operation (reef effect), or disturbed during operation (WESTERBERG 2000).

#### **Vindeby, Denmark**

This wind farm with 11 turbines was built in 1991 in the Baltic Sea 1.5 km off the north coast of Lolland. It was thought that an artificial reef habitat including blue mussels (*Mytilus edulis*) developed on the turbine foundations. Fish stocks increased after the construction of the wind farm (LEMMING 1999, cited in PERCIVAL 2001).

#### **Horns Rev, Denmark**

Due to the construction of the wind turbines hard substrate was introduced to the Horns Rev area. Each turbine is surrounded by a scour protection of stones, with a diameter of

about 20 m. Therefore, about 0.025 km<sup>2</sup> of soft bottom seabed (0.1% of the total wind farm area) are replaced by hard substrate. In addition, the turbines themselves (4 m diameter of the monopile foundation) present habitat for epifaunal organisms. In 2003, the year after the construction of the wind farm, seaweed and dense aggregations of blue mussels were growing on the hard substrate introduced (controlled by the starfish *Asterias rubens*), with mobile organisms occurring increasingly towards the sea bottom. Stable communities are expected to occur only 5-6 years after construction. Compared to the normal soft bottom seabed fauna, the food availability for fish was estimated to increase by eight times. Close to the new hard bottom fauna, a total of 14 fish species were observed, with some of them present in shoals and probably attracted by the increased food supply (LEONHARD & PEDERSEN 2004).

Compared to the pre-construction period (sampling in September 2001), the soft bottom benthos fauna in the wind farm area changed significantly during the operational period (sampling in September 2003). However, no difference was detected between the wind farm area and a reference area, indicating that natural variation rather than the operating turbines was responsible for the change, to which an increase in the particle size of the sediment seems to have contributed. The authors of the report on the infauna (BECH *et al.* 2004) stress that the Horns Rev area is a highly dynamic environment with migrating bedforms. When comparing a pre-construction survey (February/March 2002) with a survey during operation (March 2004), no negative impact from the wind farm could be detected for sandeels (JENSEN *et al.* 2004), an important prey for seabirds.

### **Nysted, Denmark**

The concrete foundations and the scour protection of stones (total diameter: 25 m) introduced about 0.04 km<sup>2</sup> of hard substrate into the wind farm area, i.e. 0.17% of its total area. In October 2003, 19-49 weeks after the deployment of the foundations and 16-28 weeks after the placement of stones into and around the foundation, a fouling community of mussels, barnacles and macroalgae had started to develop. The thick layer of mussels at a monitoring mast in the wind farm six years after its construction demonstrates that this community is in its first stages and further development can be expected (BIRKLUND & PETERSEN 2004).

#### **5.1.4 Habituation**

Due to the short time the offshore wind farms have been in operation and because of relatively short durations of the environmental studies, it has so far not been possible to draw conclusions about habituation of seabirds to turbines at sea. The presence and behaviour of some species within wind farms suggests that they became accustomed to the turbines, but this is difficult to judge for species avoiding wind farms, at least in the first years of their presence. However, the quite obvious avoidance of the Horns Rev wind farm by divers and auks was maintained during the second year of operation (PETERSEN 2005). This is partially true, too, for the Common Scoter, but its avoidance decreased in the surrounding zones compared to the first year of operation (PETERSEN 2005). This may have been an effect of local food distribution (which has not been investigated). That habituation can occur has been demonstrated in the case of several small wind farms located at coastlines, which are regularly crossed by Cormorants, ducks, gulls and terns on flights between breeding colonies, roosts and offshore foraging areas (STILL *et al.* 1996, DIRKSEN *et al.* 1998a, 1998c, PAINTER *et al.* 1999, VAN

DEN BERGH *et al.* 2002, EVERAERT 2003). Birds flying close to turbines still show changed flight paths or even panic reactions (DIRKSEN *et al.* 1998a, VAN DEN BERGH *et al.* 2002, EVERAERT 2003). This was also observed in the evening flights of gulls to their night roosts at the Oosterbierum wind farm (2 km inland), where habituation was found to lead to calmer reactions instead of a reduced number of reactions (WINKELMAN 1992c). However, lacking barrier effects in flights to and from roosts or breeding colonies do not necessarily mean that wind farms are used as foraging or resting areas, i.e. habitat loss cannot be excluded on the basis of flights observed in a wind farm.

### 5.1.5 Summary of Species-Specific Effects of Offshore Wind Turbines on Seabirds

In this section, the results of studies from operating offshore wind farms and relevant results from onshore wind farms (Sections 3.1.1. to 3.1.3.) are summarised for the 35 seabird species regularly occurring in the German parts of the North and Baltic Seas (GARTHE *et al.* 2003a).

**Red-throated Diver and Black-throated Diver:** Although single divers were seen close to and even within the Nysted wind farm, the results from aerial surveys at Horns Rev and Nysted suggest that divers strictly avoid swimming or flying within wind farms. Low densities of divers were found at Horns Rev even in the WF+2 and WF+4 zones, indicating a typical avoidance distance of at least 2-4 km. Based on much less data, the same tendencies were recognised in Utgrunden. The strong avoidance of wind farms corresponds to the large escape distances observed in divers when encountering approaching ships. Since one collision victim was found at a coastal wind farm, divers must be considered as vulnerable to collision.

**Great Crested Grebe:** No information available.

**Slavobian Grebe:** The only information refers to four and five birds which migrated in the sub-zones without turbines near the wind farms Utgrunden and Yttre Stengrund, respectively, but this small sample size does not allow any conclusions to be drawn (Tables 4 and 5).

**Red-necked Grebe:** The only information about red-necked grebes and offshore wind farms refers to a flock showing panic reaction when crossing the Horns Rev wind farm.

**Fulmar:** The scarce information on this species refers to one bird heading south towards the Horns Rev wind farm, which deviated westward instead of flying into the wind farm. Three birds seen there during transect observations were flying outside the wind farm area. One casualty found at the onshore wind farm Blyth Harbour shows that even this usually low-flying species is at risk of collision.

**Sooty Shearwater:** The only bird seen during transect observations at Horns Rev was flying outside the wind farm, but no other information is available.

**Gannet:** No Gannets were recorded within the wind farm during aerial surveys at Horns Rev, and decreasing Jacobs indices in the surrounding zones suggest that this species avoids the wind farm area. This is underscored by the facts that only 1% of all Gannets were observed within the wind farm area via transect observations, and all flight paths recorded by radar kept their distance from the turbines.



**Cormorant:** This species does not generally avoid offshore wind farms. Cormorants resting on the foundations of turbines were reported from the Horns Rev, Tunø Knob and Nysted wind farms, and within the latter, large feeding flocks were observed. Foraging close to turbines was also seen at Utgrunden (and in Horns Rev the closely related Shag did so). Locally staging Cormorants regularly fly through rows of turbines (Utgrunden, Blyth Harbour), but on the other hand a large fraction of radar observations at Nysted can be attributed to this species, indicating that flying around the wind farm is common. The existence of a barrier effect is also clear from Horns Rev, where only 5% of all observed cormorants crossed transect lines concomitant with flights through the wind farm. Also at Utgrunden, the zones and sub-zones of the Kalmar Sound which include the turbines were used to a significantly lower extent by migrating Cormorants during operation than during the pre-construction period. Whereas in Horns Rev all Cormorants were flying at rotor height, only 10% did so at the onshore wind farm Blyth Harbour. Collisions victims were found at two coastal wind farms.

**Greater Scaup:** Although the results on nocturnal flight paths of diving ducks at the “semi-offshore” wind farm at Lely on the IJsselmeer primarily refer to Tufted Ducks, the temporary presence of Greater Scaups at this site sheds light on this species as well. The row of turbines, which intersects the diving ducks’ flight path between foraging and resting areas, was generally avoided, but on moonlit nights some birds flew through instead of around the wind farm. Migration along sub-zones containing the turbines at Utgrunden and Yttre Stengrund further indicates that offshore wind farms do not act as barriers for Greater Scaups. Near the IJsselmeer seawall, the Greater Scaup has been found as a collision victim.

**Eider:** By far the most thoroughly investigated species in connection with offshore wind farms. Foraging Eiders occurred at all sites between the turbines or close-by, but numbers were quite low before construction and during operation at Horns Rev, Nysted and Yttre Stengrund. Eiders were most present in the Tunø Knob wind farm, where the detailed study found that fluctuation of bird numbers was mostly due to changes in food supply. With respect to flight behaviour when approaching offshore turbines, there seem to be differences between migrating birds and those making local movements. Based on very large sample sizes, especially at Utgrunden, Yttre Stengrund and Nysted, it can be concluded that most migrating Eiders avoid flying through wind farms and rather fly around them. Such a barrier effect was also found for local movements at Tunø Knob at night, in particular on dark nights. In the daytime, there is a general statement from the Utgrunden study that foraging Eiders fly back and forth between the turbines. The row of turbines on the pier of Blyth Harbour was regularly passed by Eiders flying into the harbour or back during the first 2.5 years of the study. This seemed to be dangerous, for at least 12 birds collided with turbines. At offshore wind farms, detouring lowered collision risk considerably, although some flocks were reported to migrate between the turbines. According to data from Utgrunden and Yttre Stengrund, collision risk was on the one hand decreased by increasing flight altitude above rotor level when crossing the turbine rows. On the other hand, Eiders migrating near turbines increased flight altitude into the range of rotor height in the same wind farms, but the proportion of flocks involved in such high risk situations is very low. As a result, only one daylight collision was observed during the studies at the two Swedish wind farms, which included several hundred thousand birds. By contrast, a relatively large proportion of migrating Eiders (0.9% at night, 0.6% at daytime, including some geese) approached to less than 50 m from the Nysted turbines.

**Long-tailed Duck:** Although Long-tailed Ducks are not generally scared away by wind farms, their numbers were found to decrease after the construction of wind farms. At Nysted, the wind farm area changed from a preferred site (pre-construction phase) to an avoided site (construction and operational phase). At Utgrunden, Long-tailed Ducks remained in their foraging sites after the construction of turbines, but numbers were lower than before. In both studies it is unknown whether changes in the food supply contributed to the decline, but at Utgrunden, displacements appeared to be caused by service boats rather than by the turbines themselves. Based on a general statement it can be assumed that birds foraging at Utgrunden fly back and forth between turbines during daylight hours.

**Common Scoter:** Although Common Scoters are very abundant in the Horns Rev area, high year-to-year variation in numbers and distribution and lack of supplementary information on food supply make the interpretation of the results obtained by aerial surveys complicated. However, because only about one tenth the number of Common Scoters expected according to the baseline studies actually occurred within the wind farm and their numbers also dropped in the WF+2 and WF+4 zones, they seem to avoid operating wind farms strongly. It is noted that Common Scoters have been reported to occur in the areas of other offshore wind farms (and perhaps close to the turbines), but these reports provide no usable data, except for one observation of a flock of 12 birds within the Nysted wind farm and a map from Utgrunden with flocks less than 1 km from turbines. At Horns Rev, most Common Scoters seen flying were local staging birds. Those disturbed by ships in the vicinity of the wind farm flew around the turbines at a distance of 300-1000 m or even turned back. This strong avoidance is confirmed by only a very small fraction (1.1%) of birds flying inside the wind farm during transect observations. In a sub-sample of flocks observed visually, all birds either landed on the water well in front of the wind farm or changed their flight direction without entering. However, radar tracking has confirmed that Common Scoters actually do cross this wind farm.

**Velvet Scoter:** Like Common Scoters, only a very small share (0.6%) of the few observed Velvet Scoters passed the transect lines through the Horns Rev wind farm. By contrast to the pre-construction period, this species was not seen to migrate through the sub-zones with turbines at Utgrunden, and only a few did so at Yttre Stengrund. A barrier effect for flying Velvet Scoters can thus be assumed.

**Red-breasted Merganser:** At Utgrunden, Red-breasted Mergansers were present less than 1 km from the turbines. From occasional observations and the diurnal pattern of presence, it was concluded that service boats displace the birds temporarily, whereas operating turbines do not cause major disturbance. A total of 14 birds were seen in or near the Nysted wind farm during aerial surveys. At the Utgrunden and Yttre Stengrund wind farms, Red-breasted Mergansers have been recorded crossing the rows of turbines more often than other seabirds.

**Pomarine Skua:** No information available.

**Arctic Skua:** The only skua species commonly occurring at Horns Rev seems to fly into the wind farm without being disturbed; it is probably attracted by the gulls foraging between the turbines. During the transect observations, 26% of all birds crossed the transect lines which represent flights within the wind farm area. By contrast, it was assumed that Arctic Skuas avoided the Utgrunden wind farm because of the low share of that species migrating in the respective zone of the Kalmar Sound.

**Great Skua:** As only two birds were seen on transect lines outside the Horns Rev wind farm, no significant information is available on this species.

**Little Gull:** The Horns Rev wind farm area was avoided by Little Gulls before and during construction, but information for the operational period is contradictory. Data obtained throughout the first year of operation indicate preference for the wind farm area, whereas data from two spring seasons suggest avoidance. During one aerial survey (December 2003), the majority of all Little Gulls observed were foraging between the turbines. That the wind farm is not generally avoided is further confirmed by visual observations, in which 13% of the birds were seen to cross transect lines, which represent flying into or within the wind farm. However, as flight altitudes were unknown, no assessment of collision risk is yet possible.

**Black-headed Gull:** There are no data to date permitting assessment of potential habitat loss for this species at offshore wind farms. At coastal wind farms (Maasvlakte, Blyth Harbour), regular movements between breeding colonies, roosts and foraging sites cross rows of turbines. From Horns Rev, it is known that large shares (40% of observed birds crossing transect lines) fly through the wind farm. As the majority of gulls at this site fly at rotor height, Black-headed Gulls appear vulnerable to collision risk. In fact, the species was noted as a collision victim at 13 wind farms at or near the coast.

**Common Gull:** Although information about potential habitat loss is lacking, commonly occurring flights through the Horns Rev wind farm (46% of all birds crossing transect lines) suggest that there is at least no barrier effect for this species. As stated for gulls as a whole at Horns Rev, high percentages of birds flying at rotor height may indicate increased collision risk. At seven coastal wind farms, Common Gulls were found to collide with turbines.

**Lesser Black-backed Gull:** No information on potential habitat loss is available for this offshore-foraging species. For birds on flights between breeding colonies and foraging areas, it was observed that wind farms at the coastline do not act as a barrier. However, different degrees of reaction (detouring manoeuvres, turns) were observed for gulls, including large shares of Lesser Black-backed Gulls, at Zeebrugge (14-64% showing reaction) and Maasvlakte (3%) when flying through rows of turbines. The absence of a barrier effect was also observed at Horns Rev, where 32% of all birds crossing transect lines were flying within or into the wind farm. At Horns Rev and Maasvlakte, most gulls (including this species) were passing at rotor height, but in Zeebrugge only 32% did so. That this species is at risk of collision is shown by collision casualties found at Zeebrugge.

**Herring Gull:** Offshore turbines are not generally avoided by Herring Gulls, which were regularly seen in the Nysted and Horns Rev wind farm areas. At Horns Rev, Herring Gulls became more abundant during the operational phase and especially during construction. It was assumed that this was caused by attraction to slowly moving ships or the possibility of roosting outside the water; Herring Gulls were occasionally seen to rest on foundations. At the same site, 37% of the birds flew within the wind farm during transect observation. The lack of a barrier effect is known from coastal wind farms as well, although up to 42% of passing birds still show detouring manoeuvres or turns. Whereas at Horns Rev most gulls (including Herring Gulls) flew at rotor height, most birds were found to fly at altitudes below the rotor at coastal wind farms. Nevertheless, Herring Gulls were reported as collision victims at 11 onshore wind farms.

**Great Black-backed Gull:** At Horns Rev, Great Black-backed Gulls changed from strong avoidance during pre-construction to strong preference during operation. Like Herring Gulls, the attractive effects of ship traffic and resting places on foundations can

be assumed as the reasons for the increase (the latter is proven by visual observations). No barrier effect appears to exist, as 35% of all birds seen in transect observations were flying within the wind farm. This corresponds to the observation that Great Black-backed Gulls commonly cross the row of turbines at Blyth Harbour. High percentages of gulls flying at rotor height at Horns Rev (but only 13% at Blyth Harbour) and collision victims found at Blyth Harbour and Zeebrugge indicate high vulnerability to collisions.

**Kittiwake:** Despite their low numbers recorded during aerial surveys, Kittiwakes do not seem to avoid the Horns Rev wind farm: 24% of the birds observed crossing transect lines were within the wind farm, and resting on the foundations was reported. Casualties at two coastal wind farms provide evidence of vulnerability to collisions.

**Caspian Tern:** Little or nothing is known about Caspian Terns at wind farms, except that four birds were observed flying in sub-zones with no turbines at Utgrunden and Yttre Stengrund (Tables 4 & 5).

**Sandwich Tern:** According to transect observations at Horns Rev, Sandwich Terns commonly fly within the wind farm (51% of birds seen). Observations of flight altitude showed the great majority of terns flying low, and only 9% at rotor height; hence, vulnerability to collision may be relatively low.

**Common Tern and Arctic Tern:** The authors of the Horns Rev study do not consider the lack of these species within the operating wind farm to be of great importance, because the sample size was low and the birds (which actually preferred the zones around the wind farm) were concentrated in a few flocks. Because Common/Arctic Terns have been seen resting on the railings of the foundations, but on the other hand often left the area between the turbines soon after flying in, the results involving potential habitat loss are contradictory. The observed proportion of 30% of flying birds crossing the transect lines representing flights within the wind farm demonstrate that there is no general avoidance reaction to offshore turbines. Like at Horns Rev (9% of all terns), it was noted at Zeebrugge that only few birds (7%, Common Terns) fly at rotor height and pass below the rotor – just as at Yttre Stengrund, where migrating Common/Arctic Terns maintained their flight altitude of approximately 10 m even close to the turbines and did not deviate from their course. Common Terns flying to a night roost at Den Oever evaded a single turbine laterally, and evasive behaviour was noted in 4-31% (Zeebrugge) and 5% (Maasvlakte) of passing Common Terns. However, collisions can still occur, as casualties have been reported from Zeebrugge.

**Black Tern:** Information about Black Terns is restricted to their behaviour at a single coastal turbine at Den Oever, where they evaded laterally during flights to the night roost. One casualty was found at a coastal wind farm in Germany.

**Guillemot and Razorbill:** The Horns Rev wind farm seems to be avoided strictly by both auk species. Aerial surveys failed to record any bird within the wind farm during either construction or operation, and reduction in numbers was also noted in the WF+2 and WF+4 zones during operation (with no record there at all during construction). Furthermore, only two out of 53 birds (4%) flying across transect lines during visual observations were within the wind farm. Avoidance of wind farms is also indicated by a low proportion of auks migrating in the zone of the Kalmar Sound, in which the Utgrunden wind farm is located. Despite the general low flight altitude, a Guillemot was found as a collision victim at a coastal wind farm.

**Black Guillemot:** Before the Utgrunden turbines had been built, four out of 12 Black Guillemots migrating through zone C were seen in the sub-zones which later contained the wind farm. During operation, all 34 birds of zone C kept away from the wind farm sub-zones (Table 4), perhaps indicating avoidance.

**Little Auk and Puffin:** No information available.

## 5.2 Quality of Studies and Results

When discussing the quality of the studies on seabirds conducted at operating offshore wind farms, it is important to differentiate between the design and coverage of the studies on the one hand and how and to which extent the results are reported on the other hand. It must be stressed for all studies that the harsh marine environment restricts investigations to calm weather conditions, which are not representative, especially for autumn and winter. The researchers cannot be blamed for this shortcoming, because the methods applied cannot be used, e.g. during storms or high waves.

### Tunø Knob, Denmark

A well-designed BACI study was conducted at Tunø Knob, some aspects of which lasted up to four years. However, a major point of criticism is that the baseline period for bird counts lasted only two months (mid-February to mid-April 1995), and largely addressed only one species, the Eider, with fragmentary results for one more, the Common Scoter. Moreover, the study was restricted to the winter and therefore failed to include: i) possible offshore foraging trips of breeding birds; ii) the moulting period of seabirds as a period of high sensitivity; and iii) migration periods with turnover of individuals which bring relatively high proportions of populations into contact with the wind farm.

The authors of the Tunø Knob study proposed that the high annual and spatial variation in Eider numbers was mainly caused by variations in the availability of profitable size classes of mussels. However, earlier comments raised the question as to whether the construction of the wind farm might have influenced the mussel abundance by sediment disturbance (TINGLEY 2003). Even when taking into account annually fluctuating numbers, Eider numbers increased in the fourth year of the study by 300% in the sector containing the turbines, but on average by 1900% in adjacent sectors. While the authors refer this to natural variation, TINGLEY (2003) pointed out that it is “more likely that these data indicate short-distance disturbance effects caused by the wind farm.” Detection of natural variation was impeded by the fact that only one baseline year was included in the study.

The radar studies on the nocturnal flight behaviour of Eiders are of high value, because in contrast to other wind farms, staging birds were observed during their local movements. In addition they show, how important it is to consider the conditions under which seabirds fly, especially visibility.

When assessing the results from Tunø Knob in the context of the general effects of offshore wind farms on seabirds, the fact that the farm has relatively few and – more importantly – relatively small turbines, which are not illuminated at night, should be considered. It is unclear how the findings from Tunø Knob can be transferred to large wind farms with turbines more than twice as high.

### **Utgrunden and Yttre Stengrund, Sweden**

Compared to other studies, the investigation of the effects of the two wind farms on staging seabirds in the Kalmar Sound appeared to be less thorough and are based on a qualitative rather than a quantitative or systematic approach. First of all, counting methods did not include those used for seabirds in offshore areas for many years (TASKER *et al.* 1984, GARTHE *et al.* 2002) or developed recently (NOER *et al.* 2000, DIEDERICHS *et al.* 2002). Secondly, methods used, study plots and results are poorly documented and allow assessment only after some of the data has been recalculated. The results are only qualitative and only include some species in winter and spring, but not during the summer months. The decline in bird numbers found in several species after the construction of the wind farms are difficult to relate to the presence of the turbines. Natural variation cannot be excluded, especially because no information is available on food supply and related subjects. Finally, some results presented in different tables are contradictory, as mentioned above concerning divers. For these reasons, the seabird studies from Utgrunden and Yttre Stengrund have contributed relatively little to our understanding of seabird reactions to offshore wind farms as far as staging birds are concerned. One positive contribution has, however, been the description of the effects of service boats on the seabirds.

Much better documentation is available for flying seabirds. However, these results mainly refer to migrating birds, rather than flights of staging birds. The type of radar used did not allow detection of small flocks (e.g. smaller than 45-100 Eiders), which is why all local movements are probably excluded. Furthermore, the majority of birds observed were Eiders, and results of other species are often summarised without naming the species involved. Study periods were restricted to the peak periods of Eider migration, which also restricts the number of species included in the observations. A highlight of the studies is the use of an optical rangefinder, which allowed following the flights of seabirds close to turbines in 3-D. Regarding the focus of this report, the results of migrating seabirds from Kalmar Sound can provide some indication as to their behaviour, but in general, these results cannot be transferred to local flights of staging birds.

For the first time, Pettersson (2005) gave an estimate of collision risk for migrating waterbirds at the two offshore wind farms in the Kalmar Sound. He arrived at a value between one 20<sup>th</sup> and one 150<sup>th</sup> of those arrived at in calculations for a coastal wind farm in Belgium (see Table 9). It is important to realise that this estimate is based mainly on observations during good visibility and was extrapolated from only one witnessed collision. Furthermore, the great majority of data comes from Eiders, which are known to generally detour around wind farms. Hence, the low rate of collisions reported is not representative for seabirds in general and cannot be applied to staging seabirds.

### **Horns Rev and Nysted, Denmark**

The bird studies at Horns Rev and Nysted followed a shared design and are therefore well comparable. They focused on the distribution of seabirds (aerial surveys) and the flight paths of birds (radar studies). The latter mostly referred to migrating birds, which were in fact the object of these studies. Hence, general answers to the question as to the flight behaviour of staging seabirds or of those conducting foraging flights could not be obtained. However, visual observations from the transformer station at Horns Rev gave valuable insight into the reactions of birds approaching the wind farm, and these

observations to some extent involve local movements. Unfortunately, such observations are lacking from Nysted, where they might have been conducted from shipboard.

In order to investigate the distribution of seabirds in a large study area, the researchers chose aerial surveys rather than ship-based counts. Regarding the species of interest and those actually occurring in the area, this was certainly the right decision, because for most of these species aerial surveys are suitable or even recommended (CAMPHUYSEN *et al.* 2003, GARTHE *et al.* 2004). The standardised surveys made it possible to apply the selectivity index of Jacobs (1974) which is independent of the fluctuations in the numbers of seabirds present. Unfortunately, no surveys took place in late May, June or July, which prevented assessment of the effects on foraging seabirds during the breeding season. However, the inclusion of approx. three years of the pre-construction period provided a good basis for the detection of effects from the later construction and operation of the wind farm.

A major shortcoming of the seabird surveys is the lack of information on food supply. The objective of the benthos studies carried out at Horns Rev was to examine the effects on benthic organisms, not to provide e.g. a picture of their large-scale distribution or their annual variation. Especially the strong numerical and distributional fluctuations of the Common Scoter, one of the key species in the environmental impact assessment, could have been much better explained and might have led to a more accurate estimate of wind farm effects. The same is true of Long-tailed Ducks at Nysted.

Finally, the large number of turbines inevitably leads to frequent ship traffic for service and maintenance. Unfortunately, the amount of ship traffic in the wind farm area was not recorded during the aerial surveys. Therefore, effects ascribed to wind turbines may at least in part be due to disturbance by ship traffic (PETERSEN *et al.* 2004). At Horns Rev however, three of the four surveys conducted during the operational period of 2003 – all except the September survey – took place in periods of low ship traffic, as indicated by the logbook of a small vessel (TOUGAARD *et al.* 2004).

Despite some of the problems addressed above, the two Danish studies have substantially enhanced the knowledge of seabirds at offshore wind farms.

## **5.3 Effects of Other Technical Impact Factors on Seabirds in Offshore Areas**

### **5.3.1 Offshore Platforms**

As to habitat loss and barrier effects for seabirds, only little information is available from offshore installations, most of it from oil drilling platforms. Drilling platforms generally attract seabirds, leading to higher bird densities around them than in the adjacent sea areas (HAUGE & FOLKEDAL 1980, TASKER *et al.* 1986, WIESE *et al.* 2001). Apart from the opportunity for resting, the most important reason for such seabird concentrations seems to be the improved food supply due to waste, exhausted migrating landbirds, and zooplankton and small fish which are attracted at night by the lights (BOURNE 1979, JONES 1980, TASKER *et al.* 1986, WIESE *et al.* 2001). In addition, epibenthic organisms growing on the foundations may alter feeding conditions, as they can be preyed upon directly or attract other potential food organisms like fish (reef effect; CARLISLE *et al.* 1964, ORTEGO 1978, WOLFSON *et al.* 1979, JONES 1980, BAIRD 1990).

In Europe, attraction by artificial lights from offshore platforms, which occasionally causes collisions or burning in gas flares, is mostly reported for passerine migrants (SAGE 1979, HELBIG *et al.* 1979, HAUGE & FOLKEDAL 1980, JONES 1980, MÜLLER 1981, WALLIS 1981, DIERSCHKE 2004). In the Canadian Atlantic, it does not seem uncommon for Leach's Storm-petrels and Little Auks to be attracted by drilling platforms at night, with thousands of the latter species circling around a platform for hours (WIESE *et al.* 2001), but there is only one report of several hundreds supposed Storm Petrels being incinerated in the gas flare of a drilling rig in the North Sea (SAGE 1979). Seabirds that feed nocturnally on bioluminescent zooplankton, especially juveniles just after fledging, seem instinctively attracted by artificial light sources in their search for prey (IMBER 1975).

### 5.3.2 Sand and Gravel Extraction

There are no studies directly related to the effects of aggregate extraction on seabirds. However, in addition to disturbance caused by human activity above the sea surface, the consequences of the deterioration of the benthic communities certainly have an impact on the food supply, and thus on the suitability of feeding areas for seabirds. For seabirds feeding on bivalves (e.g. scoters) which live in the upper layers of the sediment, resources are removed. Disturbance can also be expected for sandeels, especially if the preferred grain size of the sediment (WRIGHT *et al.* 2000) is changed. Sandeels are a key factor in marine food webs and of particular importance to seabirds, including such species listed in Annex I of the EU Birds Directive as the Red-throated Diver, the Sandwich Tern, the Common Tern and the Arctic Tern (FURNESS & TASKER 2000). Reduced availability of sandeels was found to reduce the breeding success of seabirds (FURNESS & TASKER 2000, FURNESS 2003). Therefore, it is likely that areas used for sand and gravel extraction will be of less value to seabirds for an indefinite period.

### 5.3.3 Ship Traffic

Behaviour of seabirds in relation to ships can be linked directly to the question of the environmental impacts of offshore wind farms. Not only the construction, but also the operation of wind turbines causes increased ship traffic for maintenance and service. While especially gulls are often associated with ships (e.g. GARTHE & HÜPPOP 1994), other seabird species are disturbed by them. However, information about habitat loss caused by ship traffic is scarce. During ship-based surveys in northern Europe it was noted that flushing distance varies among seabird species. Strong escape/avoidance behaviour and/or large flushing distances have been noted for divers, Slavonian Grebes, Long-tailed Ducks, scoters and Cormorants, while the opposite is true of Gannets, skuas, gulls and terns (intermediate behaviour in Great Crested Grebes, Red-necked Grebes, Eiders, Red-breasted Mergansers and auks; GARTHE & HÜPPOP 2004, GARTHE *et al.* 2004). Nearly the same assessment was made by CAMPHUYSEN *et al.* (1999), who included "escape behaviour" in a "traffic disturbance index". Compared to the above, these authors saw escape behaviour caused by ships as more pronounced in Eiders, but less so in Slavonian Grebes, Long-tailed Ducks and Red-breasted Mergansers.



It was discussed earlier that areas with much ship traffic tend to be avoided by the more sensitive species, especially divers and scoters (HÜPPOP *et al.* 1994, MITSCHKE *et al.* 2001). For example, densities of wintering divers were observed to be considerably lower in the Elbe shipping lane compared to the sea area just north of it (HÜPPOP *et al.* 1994). In the Pomeranian Bay, Long-tailed Ducks avoided the shipping lane despite of the high biomass of harvestable prey in part of this zone. This was probably due to an unfavourable energy balance caused by frequent flushing and diving when ships are passing (KUBE 1996).

The flushing distance of Common Scoters was examined experimentally in Liverpool Bay in the Irish Sea (KAISER 2004). With combined visual and radar observation, the distance between a ship cruising at 10 knots and flocks taking off for flight was estimated. Although no correlation between flock size and flushing distance was found, flocks flushing below 1 km distance were significantly smaller than those taking off at distances of 1-2 km from the approaching ship. Therefore, 1 km is the critical flushing distance at which flock size increased dramatically. The vast majority of large flocks took off at distances greater than 1 km. Smaller flocks (<15 birds) let vessels approach more closely, but showed alert postures before flying away. In addition, the observers noted wave effects, i.e. flushed flocks at closer distances prompted flocks further away (even >2 km) to take off as well.

## 6 Discussion

Compared to only a few years ago, the results of studies at offshore wind farms now provide improved insight into the reactions of seabirds towards these obstacles. While it is still difficult to give even rough estimates of additional mortality due to fatal collisions, it is possible for a number of species to estimate habitat loss and fragmentation – despite the lack of information on long-term habituation.

### 6.1 Collision Risk

Since several seabird species were observed entering offshore wind farms, a general collision risk can be assumed for them. This must be kept in mind when discussing the possible impact on protected species. For example, four species listed in Annex 1 of the EU Birds Directive (Little Gull, Sandwich Tern, Common Tern and Arctic Tern) are known to fly between offshore turbines. Unfortunately, knowledge related to collision risk is very limited and mainly refers to migrating birds rather than to local movements of staging birds or seabirds foraging offshore in the breeding season. To date, only one fatal collision has been observed (migrating Eiders, PETTERSSON 2005), and very few flight altitude measurements have been carried out near offshore wind farms (mostly for migrating seabirds). Hence, most information on collision risk of seabirds comes from coastal wind farms.

Observations at coastal wind farms are helpful when estimating the collision risk for seabirds. According to casualties recorded at turbines up to 4 km inland, at least 13 of 35 seabird species regularly occurring in German waters are affected by collisions. Primarily, gulls were reported as colliding with turbines, which indicates that birds which commonly fly into wind farms are most affected. This is underscored by the fact that the rate of collision calculated for gulls and terns at a coastal wind farm (EVERAERT *et al.* 2002) is many times higher than that estimated for migrating Eiders, which generally detour around wind farms (PETTERSSON 2005). The general risk is underlined by the fact that many birds pass turbines at rotor height (STILL *et al.* 1996, VAN DEN BERGH *et al.* 2002, EVERAERT 2003). In addition, the study at Zeebrugge has shown that the direction of turbine rows compared to the flight direction of seabirds is an important factor determining collision risk (more collisions when turbines are perpendicular to the flight paths, EVERAERT *et al.* 2002).

The studies conducted at both coastal and offshore wind farms came to the result that seabirds mostly avoid collisions by either flying detours around wind farms and turbines (e.g. DIRKSEN *et al.* 1998c, TULP *et al.* 1999, KAHLERT *et al.* 2004b, PETTERSSON 2005, CHRISTENSEN & HOUNISEN 2005) or by conducting swerves when ultimately confronted with the rotor (e.g. WINKELMAN 1992c, EVERAERT *et al.* 2002, PETTERSSON 2005). However, the detectability of the turbines seems to have an effect on the actual risk. In poor visibility – at night or under foggy conditions – migrating birds reacted to turbines to a lesser degree and at closer distances than under better conditions in daylight (KAHLERT *et al.* 2004b, CHRISTENSEN & HOUNISEN 2005, PETTERSSON 2005), but at Nysted a higher percentage of those Eiders and geese entering the wind farm came closer than 50 m to the turbines during daytime. Furthermore, radar tracking of nocturnal flights at the Horns Rev wind farm illustrated that adjustments of flight paths are less effective in avoiding turbines (CHRISTENSEN & HOUNISEN 2005). This implies that turbines, even when illuminated, are more difficult to detect by flying birds in darkness.

In fact, in a coastal wind farm in the Netherlands, a higher collision rate for birds flying through the rotating blades was observed at night (28%) than in daytime (7%) – although this study does not refer only to seabirds (WINKELMAN 1992b). In addition, STILL *et al.* (1996) pointed out that four of the 12 Eider collisions recorded at Blyth Harbour occurred within only one week, at poor visibility. In contrast to the findings of migrating birds, nocturnal flights of staging birds approached the wind farms at Lely (diving ducks) and Tunø Knob (Eiders) less during dark nights than on moonlit nights (DIRKSEN *et al.* 1998c, TULP *et al.* 1999). It is possible that staging birds are aware of the turbines within their home range and keep away from them under poor visibility conditions, but do not mind crossing the wind farm when they can detect obstacles.

Finally, regarding the nocturnal illumination of offshore turbines, it is unknown whether seabirds are attracted by artificial lights, which would increase collision risk. In the North Sea, there is only one uncertain report about Storm Petrels which had been attracted by the gas flare of a drilling rig (SAGE 1979; cf. also reports from the Canadian Atlantic in WIESE *et al.* 2001). This lack of information highlights the importance of future studies on mortality caused by offshore wind farms.

## 6.2 Habitat Loss

Physical habitat loss caused by the introduction of hard substrate into a soft bottom environment seems negligible, because the proportion of soft bottom area lost is low (far below 1%) and the benthos as a food resource for seabirds appears hardly affected. For habitat loss due to displacement, studies in Denmark and Sweden have shown that at least in the first year after construction six seabird species (Red-throated Diver, Black-throated Diver, Gannet, Common Scoter, Guillemot and Razorbill) strongly avoided offshore wind farms (Table 18). In addition, Long-tailed Ducks did not generally keep away from them, but were present in reduced numbers. Another seven species occurred within wind farms and showed few obvious effects (Table 18). The numbers of three species (Little Gull, Herring Gull and Great Black-backed Gull) increased, and at least for the large gulls, an attraction effect by ship traffic and/or by resting opportunities on the foundations of the turbines can be assumed (CHRISTENSEN *et al.* 2003). For the remaining 18 species (including Fulmar, Velvet Scoter and Lesser Black-backed Gull) nothing is known on possible displacement.

Although some species appear unaffected by offshore turbines or may even gain increased food resources from invading hard bottom fauna, avoidance behaviour by other species may lead to displacement from habitats used prior to wind farm construction. The role of bird density at sea in the population dynamics of seabirds is unknown. For many species, mobile food resources such as fish stocks or discards from fishery make determination of areas of special importance difficult. The distribution of seabirds as a result of food distribution is better understood for sea ducks, which mainly rely on benthic bivalves. Prey density and water depth determine the importance of some marine areas and exclude others because food is either lacking or is too deep to allow profitable diving. Although bivalve consumption rates by sea ducks were found to be low in German waters (LEIPE 1985, NEHLS 1989, KUBE 1996), density may impact the mortality and reproduction of these and other species.

Table 18: Summary of the effects of offshore wind farms on the 35 seabird species regularly occurring in German marine areas (North and Baltic Seas). Species listed in Annex I of the EU Birds Directive are printed bold. Categories: Habitat loss – 00 strong avoidance, 0 reduced numbers, + occurring with no or only few effects, ++ increased numbers. Barrier effect – 00 strong avoidance, 0 detours occurring, + (commonly) flying through wind farms (\* including information from coastal wind farms). Fatal collisions – 00 casualties at offshore and coastal wind farms, 0 casualties at coastal wind farms.

	Habitat loss	Barrier effect	Fatal collisions
<b>Red-throated Diver</b>	00	00*	0
<b>Black-throated Diver</b>	00	00	?
Great Crested Grebe	?	?	?
Red-necked Grebe	?	+	?
<b>Slavonian Grebe</b>	?	?	?
Fulmar	?	0	0
Sooty Shearwater	?	?	?
Gannet	00	00	?
Cormorant	+	0*	0
Greater Scaup	?	0*	?
Eider	+	0*	00
Long-tailed Duck	0	+	?
Common Scoter	00	00	?
Velvet Scoter	?	00	?
Red-breasted Merganser	+	+	?
Pomarine Skua	?	?	?
Arctic Skua	+	+	?
Great Skua	?	?	?
<b>Little Gull</b>	++	+	?
Black-headed Gull	?	+	0
Common Gull	?	+	0
Lesser Black-backed Gull	?	+	0
Herring Gull	++	+	0
Great Black-backed Gull	++	+	0
Kittiwake	+	+	0
<b>Caspian Tern</b>	?	?	?
<b>Sandwich Tern</b>	?	+	?
<b>Common Tern</b>	+	+	0
<b>Arctic Tern</b>	+	+	?
<b>Black Tern</b>	?	+	0
Guillemot	00	00	0
Razorbill	00	00	?
Black Guillemot	?	00	?
Little Auk	?	?	?
Puffin	?	?	?

As density effects have not been studied in seabirds, mechanisms of habitat loss known from other birds must serve as examples. A large number of waders, many of which breed in the Arctic, spend the non-breeding season in intertidal areas along the coastlines of all continents. Like sea ducks, they feed on benthic prey. The huge amount of data on foraging, food exploitation and bird movement of coastal waders has made the effect of habitat loss well known for them: Generally, wader density correlates with prey density in estuaries, with increased bird density leading to higher mortality

rates or movement to other estuaries. Mortality increases due to lower intake rates caused by increased interference competition and more rapid exploitation of prey. Displacement to less favourable estuaries (or less favourable parts of the same estuary) usually occurs in young and subdominant individuals and also leads to lower intake rates in these individuals (GOSS-CUSTARD 1979, 1985, EVANS 1981, LAMBECK 1991, SUTHERLAND & GOSS-CUSTARD 1991). As displaced individuals cause the same effect in the new estuary, habitat loss in one site can have an impact even on birds which never use this site ("knock-on effect", DOLMAN & SUTHERLAND 1995). If density-dependent mortality also occurs in seabirds during the non-breeding season, habitat loss caused by offshore wind farms may have effects similar to those which loss of estuarine habitats, e.g. by reclamation, has for waders.

Displacement may also impact the reproduction of seabirds. Lower intake rates due to density effects may reduce body condition at departure from wintering areas and/or spring staging sites, and hence lead to arrival at breeding areas in worse condition and/or at a later time. Carry-over effects which link events (e.g. disturbance) in winter and spring with reproductive output in summer have been found in several bird species. In five populations of geese, breeding success was lower when body condition before or during spring staging was poor (Pink-footed Goose: MADSEN 1995; Greater Snow Goose: BÉTY *et al.* 2003; Lesser Snow Goose: ANKNEY & MACINNES 1978; Barnacle Goose: PROP *et al.* 2003; Brent Goose: EBBINGE & SPAANS 1995, GANTER *et al.* 1997, STOCK & HOFEDITZ 1997). Pink-footed Geese and Brent Geese exposed to human disturbance during spring staging in Norway and the Wadden Sea, respectively, showed poor body condition and reduced breeding success (MADSEN 1995, STOCK & HOFEDITZ 1997). Also, after losing habitat in reclaimed salt marshes in the Wadden Sea, displaced male Brent Geese were significantly less successful in breeding than control birds from other parts of the Wadden Sea (recalculated data from GANTER *et al.* 1997). The high connectivity between events in the annual cycle of birds was also shown by studies of the Mallard (KRAPU 1981) and a North American passerine, the American Redstart (SMITH & MOORE 2003). In the latter, early arrival of females increased the number of offspring (SMITH & MOORE 2005), indicating that right arrival time also affects breeding success. This is especially true for Arctic breeding birds, including seabirds, which must fit their breeding into a short period with no snow or ice.

If it occurs in a bottleneck situation, habitat loss can have a dramatic impact on a bird population. On their way to their Arctic breeding area, nearly all Red Knots wintering in southern South America stop over at Delaware Bay on the east coast of the USA, where they lay on fuel for the last stage of their flight, feeding nearly exclusively on the eggs of the horseshoe crab (*Limulus polyphemus*). After only a few spring seasons of shortage of prey, Red Knots faced both high adult mortality and low breeding success, leading to a dramatic population drop to nearly half the former size within only three years and a high risk of extinction of this subspecies (BAKER *et al.* 2004). If comparable bottlenecks also exist in seabirds, habitat loss would have a negative impact on their population sizes as well. It should be noted that bottlenecks for seabirds in northern Europe may occur either within an annual cycle (e.g. during the winter or spring staging), or over the course of several annual cycles, for example when most of the Baltic Sea is ice-covered in severe winters and seabirds have to move to the North Sea.

Because of the precautionary principle, the worst-case scenario where species completely avoid offshore wind farms and thus experience habitat loss should be taken into consideration. However, three open questions prevent generalisation:

First, it is still not known whether habituation will occur. Published results from the large Danish wind farms Horns Rev and Nysted cover only a short period of operation and thus as yet provide no information on habituation over a longer time scale. To date, avoidance of the Horns Rev wind farm by divers and auks was maintained during the second year of operation. The three-year study at the operating Tunø Knob wind farm overlapped strong fluctuations in both prey and bird densities; it, too cannot answer the question as to habituation. In an analysis of studies at terrestrial wind farms over several years, HÖTKER *et al.* (2004) found no general trend towards habituation, because according to the various studies, distances kept from turbines either increased or decreased over time.

Second, the size of wind farms and turbines may not be representative of future facilities, which will be larger than those built recently. For terrestrial wind farms, HÖTKER *et al.* (2004) tested the relationship between tower height and the distance birds kept during the non-breeding season. In most species, they found a positive correlation, although this was significant in only one species (the Lapwing). Therefore, taller turbines may have more pronounced effects on seabirds as well. On the other hand, distances between the turbines will also increase with turbine size and thus may offer enough space to move and forage in between them.

Third, there are indications that some of the displacements occurring in seabirds at operating offshore wind farms are caused by the traffic of service boats and even helicopters rather than by the turbines themselves (e.g. PETTERSSON 2005, PETERSEN 2005). Unless wind farms are completely free of such traffic, it will be difficult to assign reactions of birds to any source of disturbance. However, it became clear from several observations that the turbines themselves lead to avoidance by seabirds. At least some surveys at Horns Rev took place during periods of reduced or even no ship traffic (see 5.3.3). Furthermore, it was shown at the two wind farms in Kalmar Sound that flying Eiders are more likely to pass turbines when they are not operating (PETTERSSON 2005). However, the question of the respective roles of ship traffic and turbines appears to be negligible, since operating wind farms will always have some service and maintenance work. Nevertheless, future bird surveys at offshore wind farms should always include the monitoring of ship traffic in order to estimate its effect on seabirds.

### 6.3 Habitat fragmentation

Flights of seabirds can be attributed to two categories, flights between different areas used in an annual cycle (migration) and flights within areas (foraging flights, change of foraging sites, flights to roosts etc.; see below). When discussing the effects of offshore wind farms, these categories have to be reviewed separately. Whereas migrating seabirds are confronted with a wind farm only once or twice per year, frequent movements of seabirds within a staging area containing a wind farm bring seabirds close to turbines much more often (probably several times per day), and there are indications that birds are aware of the presence of the turbines (DIRKSEN *et al.* 1998c, TULP *et al.* 1999). However, knowledge about local movements of individual seabirds is scarce in some ways:

It is known that all seabirds breeding at the coast or on islands and foraging offshore regularly fly to and from their colonies; some species do so several times a day. This is most pronounced during chick rearing (e.g. Gannet, NELSON 2002; Lesser Black-backed Gull, GARTHE *et al.* 1999; Sandwich Tern, PEARSON 1968; Guillemot, GRUNSKY-

SCHÖNEBERG 1998). If wind farms present a barrier, foraging flights could last longer and cost more energy, and some foraging areas might become unprofitable.

Habitat fragmentation may also affect seabirds moving back and forth within staging areas for any reason. Outside the breeding season, seabirds feeding on discards concentrate at fishing vessels (e.g. CAMPHUYSEN *et al.* 1995) and therefore must be as mobile as fishing fleets are versatile. Other species such as divers fly in order to compensate drift (MELTOFTE & KIØRBOE 1973, NOER *et al.* 2000). Land-based observations also indicate that especially sea ducks change foraging areas within their winter quarters (e.g. BERNDT & BUSCHE 1993, HELBIG *et al.* 1996, GARTHE *et al.* 2003b). Common Scoters passing Helgoland in different directions throughout the year (DIERSCHKE *et al.* 2005) suggest movements across the German Bight between staging areas in the northern and southern parts of the Wadden Sea. Such movements even occur during the night, as recorded at the Tunø Knob wind farm (TULP *et al.* 1999). More regular flights include those between diurnal offshore foraging sites and nocturnal roosts at or near land (e.g. Red-breasted Merganser, DIERSCHKE 1987; Little Gull, SCHIRMEISTER 2001, 2002) – or the other way round as in nocturnally foraging Greater Scaups and other diving ducks (DIRKSEN *et al.* 1998b). We have the least information on such flights.

The effects of wind turbines on local movements of seabirds have been poorly investigated at sea, but additional information on this topic is available from coastal wind farms. Although migration is outside the scope of this study, the reactions of migrating birds may also help understand their behaviour when a wind farm is present in their staging or foraging area. Nevertheless, no information about their flight behaviour at wind farms is available for eight of the 35 German seabird species, and for some of the other species such information is very scarce. However, there is evidence that eight species commonly fly detours instead of crossing offshore wind farms (Table 18). This barrier effect suggests that their marine habitat can become fragmented through the establishment of wind farms, which would imply either higher energy costs due to frequent detours, or even loss of certain foraging areas, if reaching them came to be too energy-consuming. Interestingly, species showing avoidance during flight are the same as those listed in the category for habitat loss (the Velvet Scoter and the Black Guillemot are not mentioned, because information is lacking; Table 18).

Detours were also noted in another four species, but it is not clear whether this is a common phenomenon (Fulmar) or why it only occurs sometimes (Cormorant). In the case of nocturnal flights of Greater Scaups and Eiders, it was observed that the degree of darkness affects the level of detouring (DIRKSEN *et al.* 1998c, TULP *et al.* 1999). During migration, nearly all Eiders seem to fly around wind farms, but local movements also take place between turbines (TULP *et al.* 1999, PETTERSSON 2002).

Fifteen seabird species (Table 18) are known to fly through wind farms or rows of coastal turbines. Although for some species (e.g. Red-necked Grebe) it remains unclear whether this is common, most gulls and terns were observed to cross coastal wind farms on the way between offshore foraging areas and breeding colonies or roosts. It appears that these birds are familiar with the obstacles with which they are regularly confronted, but according to studies from Belgium and the Netherlands they still show avoidance behaviour (VAN DEN Bergh *et al.* 2001, EVERAERT 2003). Therefore, habituation seems to occur in breeding birds, which are more or less forced to fly through the wind farms. Observations from Horns Rev confirm that the same species do not avoid offshore wind farms. As in the section on habitat loss, the question as to whether habituation will ever occur among those species that have detoured around wind farms during the first year of operation remains open.

Regular detours and habitat loss due to fragmentation will have the same consequences as outlined in Section 4.2, i.e. reduced body condition may have an impact on mortality and reproduction. For Eiders detouring the single rows of turbines at Utgrunden and Yttre Stengrund, PETTERSSON (2005) calculated extra flight distances of 1.2-2.9 km, equivalent to 2-4 minutes extra flight time. This is only 0.2-0.5% of the 800 km long migratory journey in spring and autumn, but would be a larger proportion of smaller-scale diurnal movements. Much larger distances and times can be expected when Eiders and other seabirds are confronted with large wind farms several kilometres wide. However, it is possible that birds can compensate at least for the higher energy consumption by prolonging foraging time. Brent Geese were found to increase the duration of foraging when energy is lost due to flights caused by disturbance (STOCK & HOFEDITZ 1996). Such an adjustment of the time budget would appear easier for those seabirds which feed on a few large prey compared with those feeding on many smaller ones.

#### 6.4 Assessment Methods

Until recently, commissioning of offshore wind farms presented a difficult challenge for the responsible authorities. Although most wind farm projects in offshore areas were preceded by environmental impact assessments, the impact that construction and operation would really have on seabirds living in the respective areas remained unknown.

In a basic approach, the NERI (2000) proposed that a wind farm should not affect protected areas such as SPAs. It was concluded that the distance between wind farms and protected areas should not fall below the escape distance shown by seabirds towards wind turbines. Meanwhile, and especially as a result of the studies at Horns Rev and Nysted wind farms, such distances are roughly known for a number of seabird species. While no measure at all is necessary for some species, others seem to require a safety margin of at least 1-2 km or even more. Thus, this assessment method seems applicable, although once again, the question of habituation remains an open one, and the size of safety margins will have to be adjusted when knowledge increases. The NERI (2000) further proposed that annual mortality rates should not increase by more than 5% due to collisions with turbines. Apart from the fact that such an increase would be critical for some seabird species – an additive mortality rate of only 0.3% for the Red-throated Diver or of 3% for the Herring Gull would negatively affect their population sizes (REBKE 2005, see also DIERSCHKE *et al.* 2003) – no such assessment is yet possible, because data on collision mortality at sea are lacking. Even for transferring increased mortality data to habitat loss and habitat fragmentation, this method cannot be applied, because density-dependent mortality and carry-over effects on reproduction rates have not been investigated in seabirds.

The Scottish Natural Heritage (SNH) and the British Wind Energy Association (BWEA) have developed a methodology for impact assessment which combines the sensitivity of the seabird species occurring with the magnitude of the disturbing effects. The sensitivity refers to the legal status of the species (e.g. listed in Annex I of EU Birds Directive or cited interest of SPAs) and the proportion of the national population which will be affected. The magnitude of likely effects is determined by the proportion of the local population which will lose habitat (PERCIVAL 2001). In a matrix combining both factors, the significance of an impact results in “unacceptable” or “acceptable”, with borderline cases needing more detailed consideration (Table 19). This approach has



commonly been used by the German Marine and Hydrographic Agency (BSH) in the commissioning process for offshore wind farms in the Exclusive Economic Zone. However, the question as to which reference population area should be selected when determining the proportion of affected birds is still under discussion. Apart from this problem, recent results from seabird studies at operating offshore wind farms allow a much better assessment of the magnitude factor in this methodology. Furthermore, it is much better known which species must be considered, because some species experience no habitat loss. For those species which avoid wind farms, habitat loss can be estimated more precisely than before.

Table 19: Matrix of magnitude and sensitivity used to determine the significance of effects (see text for details). Very high and high significance indicate unacceptable impacts, whereas low and very low stand for acceptable impacts. Medium represents borderline cases, which may require mitigation measures. From PERCIVAL (2001).

		SENSITIVITY			
		very high	high	medium	low
MAGNITUDE	very high	very high	very high	high	medium
	high	very high	very high	medium	low
	medium	very high	high	low	very low
	low	medium	low	low	very low
	negligible	low	very low	very low	very low

An estimate of the importance of an area of sea can be the proportion of a population living in that area. Based on the Ramsar Convention of 1971, wetlands are of international importance when 1% of a biogeographical population occurs there regularly (at least once per year) (ATKINSON-WILLES 1972). This criterion is commonly applied in order to assess the importance of wetlands (e.g. HÖLZINGER *et al.* 1972, BERNDT *et al.* 1979, STRUWE-JUHL 2000). Although the value of 1% cannot be derived from population biology, it was proposed to apply this approximation be applied, too, for offshore areas insofar as habitat loss caused by offshore wind farms should not affect more than 1% of a population (DIERSCHKE *et al.* 2003). This criterion should be applied cumulatively, i.e. 1% refers either to the biogeographic population and all offshore wind farms along the flyway, or to the national population and only the wind farms within the waters of one country (DIERSCHKE *et al.* 2003). Apart from which threshold level is used, the recent results from studies at offshore wind farms again give a much better impression as to which species must be addressed and how large the buffer zone around a wind farm should be. It should be noted that due to a high turnover of individuals, areas used during migration may provide refuelling resources for many more birds and thus a higher proportion of the respective population than indicated by averaged counting data.

GARTHE & HÜPPOP (2004) have developed a vulnerability index for seabirds, based on their behaviour and status. Specific sensitivity indices (SSI) can be combined for all species occurring in a given area to a value representing the sensitivity of a proposed wind farm area (windfarm sensitivity index, WSI). To calculate the SSI, each species is scored on a scale of 1 through 5, according to assumed interaction with wind turbines, for nine factors: Flight manoeuvrability; Flight altitude; Proportion of time spent flying; Nocturnal flight activity; Disturbance by ships/helicopters, Habitat use flexibility; Adult

survival rate; Biogeographical population size; and European threat/conservation status. The WSI includes the densities and SSIs of all species and indicates the vulnerability of the local seabird community to wind farms. As no factors contributing to the SSI/WSI are directly related to wind turbines, but only provide parameters for assessing potential effects, the results from recent studies at operating wind farms have not been included as yet. If more data becomes available, an improvement would be to consider alteration of flight altitude when facing offshore turbines. The only known example to date is the increase of flight altitude to rotor height by migrating Eiders when approaching offshore wind farms in the Kalmar Sound (PETTERSSON 2005), which increases collision risk considerably. Further updates of SSI and WSI may become necessary if certain parameters (e.g. population size, threat) change. However, it seems worth looking at the SSI values for the species and their behaviour at offshore wind farms. Although there is much overlap, those species which avoid wind farms have higher average SSI values than those which do not (Table 20). When deleting the part of the SSI referring to collision risk (the first four factors mentioned above), it is even clearer that the vulnerable species tend to avoid offshore wind farms (Table 20). Thus, the WSI can still give a very good impression of the vulnerability of marine areas. In future, if relevant data become available for all seabird species, this index could be improved by including factors directly related to offshore wind farms such as the degree of reluctance to entering wind farms or to foraging between turbines.

Table 20: Specific sensitivity indices of seabirds (after GARTHE & HÜPPOP 2004) with known reaction to offshore wind farms. The right column gives the SSI without reference to flight behaviour. Higher values indicate higher vulnerability to offshore turbines.

Species	Avoidance of wind farms	SSI	SSI without flight (rank)
Black-throated Diver	yes	44.0	16.0 (2)
Red-throated Diver	yes	43.3	17.3 (1)
Velvet Scoter	yes	27.0	12.0 (3)
Sandwich Tern	no	25.0	10.0 (4)
Cormorant	yes/no	23.3	9.3 (5)
Eider	yes/no	20.4	8.2 (7)
Great Black-backed Gull	no	18.3	7.3 (9)
Common Scoter	yes	16.9	7.5 (8)
Gannet	yes	16.5	6.0 (13)
Razorbill	yes	15.8	9.0 (6)
Common Tern	no	15.0	6.7 (11)
Lesser Black-backed Gull	no	13.8	5.5 (15)
Arctic Tern	no	13.3	6.7 (11)
Little Gull	no	12.8	7.3 (9)
Guillemot	yes	12.0	6.0 (13)
Herring Gull	no	11.0	4.0 (16)
Arctic Skua	no	10.0	4.0 (16)
Black-headed Gull	no	7.5	3.3 (18)
Kittiwake	no	7.5	3.3 (18)

## 6.5 Cumulative Effects

According to the definition in the United States' National Environmental Policy Act, cumulative effects are "the impact on the environment which results from the incremental impact of an action when added to other past, present, and reasonably foreseeable future actions" (COUNCIL ON ENVIRONMENTAL QUALITY 1997). Therefore, effects of a single offshore wind farm should not be assessed in isolation from other actions, but rather other causes of disturbance, regardless of quality, must be considered. This seems reasonable for two reasons.

First, effects from offshore wind farms on seabirds will impact their population dynamics as soon as mortality rates and reproduction rates are affected. However, single and relatively small disturbances, such as a small offshore wind farm, will fail to have detectable impacts on a population level in most cases, but the interaction of several small disturbances may do so. This applies to all kinds of possible effects combined, i.e. habitat lost in wind farm areas directly and habitat lost indirectly due to barrier effects (both influencing mortality and reproduction), as well as direct mortality from collisions.

Second, if density-dependent mortality occurs in seabirds, it will of course be necessary to consider not only all habitats lost by all offshore wind farms combined which reduce the entire habitat available for a given species, but in addition other sources of habitat loss as well. For example, marine areas disturbed by sand and gravel extraction cannot serve as replacement habitats for seabirds displaced from wind farm areas. How cumulative effects on seabirds can be assessed was demonstrated by the example of Common Scoters in Liverpool Bay (Irish Sea), where in a total area of nearly 5000 km<sup>2</sup> this species faces impacts from fishery, shipping, wind farms and related cable routes, oil/gas platforms and related pipelines, dumping, aggregate extraction and human recreation (OAKWOOD ENVIRONMENTAL LTD 2002).

## 6.6 Gaps in Knowledge and Need for Further Studies

Although knowledge of the effects of offshore wind farms on seabirds has increased recently, there are still large gaps which prevent detailed assessment. First of all, information is very scarce or even completely lacking for a number of seabird species (see Table 18). Some, such as the Fulmar, shearwaters, the Gannet and skuas occur in the southeastern North Sea in considerable numbers only during stormy weather or even gales (e.g. BRUNCKHORST & MORITZ 1980, CAMPHUYSEN & VAN DIJK 1983, KRÜGER & GARTHE 2002, PFEIFER 2003), and no studies have been undertaken during such adverse conditions. This points to another shortcoming: the behaviour of seabirds at wind farms during periods of strong winds, which usually occur together with rain and strong waves, both of which reduce visibility. To date, nearly all results available from seabird studies at wind farms have been obtained during calm weather (CHRISTENSEN *et al.* 2003). However, some species fly more easily and more often in windy situations, as has been demonstrated for the Fulmar (FURNESS & BRYANT 1996).

Most surveys of seabird distribution at wind farms have been conducted from fast-travelling aircraft, from which the activities of seabirds could not be recorded in detail. Ship-based surveys are better suited for ascertaining what seabirds really do when they stay inside wind farms, as they allow detailed observation of foraging behaviour (SCHWEMMER & GARTHE 2005). A related question is whether and to which extent seabirds make use of the recently developed hard bottom fauna on the foundations and scour protection of the turbines, but also of the possibly increased fish stocks.

Furthermore, future studies at offshore wind farms should include large-scale monitoring of relevant prey species, which so far has been done only in the study at the Tunø Knob wind farm. This would give further insight into the habitat quality of wind farms and could help explain observed seabird distribution.

However, the major gap in knowledge is that the behaviour of individual seabirds at sea and their interactive processes are quite unknown. Further studies will inevitably have to address the general biology of seabirds, i.e. their food and habitat requirements when living at sea, but also movements within their offshore habitats. The goal must be an understanding of density effects, which is the only possible approach to assessing the impact on population dynamics. With this information, it would be much easier to determine species-specific threshold levels to be used in environmental impact assessments, not only with respect to offshore wind farms, but also when looking at other impacts from human activities. Another factor acting on the population dynamics of seabirds, direct mortality from collision, still needs much more attention. Unfortunately, an applicable method is still in its infancy (DESHOLM 2003).

## 7 Conclusions

According to the results of the seabird studies at operating offshore wind farms, it would appear that the species living in German waters behave differently when confronted with wind farms. There are several species, which actively avoid offshore turbines, including at least two species listed in Annex I of the EU Birds Directive (Red-throated Diver and Black-throated Diver), and two more species, the Common Scoter and the Velvet Scoter, of which high proportions of the biogeographic population overwinter in German waters (GARTHE 2003). In addition, the lack of avoidance behaviour in other species basically brings them into risk of collision. This also applies to Annex I species (Little Gull and four species of tern). In some other species, the construction of turbines at sea will probably cause no major problems, at least in terms of habitat loss or habitat fragmentation.

Unless possible effects of habituation are understood well, the precautionary principle should be applied when assessing possible impacts of wind farms. Moreover, since wind farms and other technical impacts already exist or are planned along many of the flyways of the respective species, replacement habitats are not always available. Therefore, cumulative effects must be considered as well, because several smaller effects would add up to impacts on entire populations. However, much better knowledge of density effects at sea is urgently required to permit an appropriate assessment of such impacts on population size. Therefore, apart from studies of effects taking place directly at the wind farms, much more basic investigation into processes acting within overwintering seabird communities as well as the individual behaviour of seabirds at sea are strongly recommended.

## 8 References

- ANKNEY, C.D., & C.D. MACINNES (1978): Nutrient reserves and reproductive performance of female Lesser Snow Geese. *Auk* 95: 459-471.
- ATKINSON-WILLES, G.L. (1972): The international wildfowl censuses as a basis for wetland evaluation and hunting rationalization. In: E. CARP (ed.): Proc. Int. Conf. Conserv. of Wetland and Waterfowl, Ramsar 1971: 87-119.
- BAIRD, P.H. (1990): Concentrations of seabirds at oil-drilling rigs. *Condor* 92: 768-771.
- BAKER, A.J., P.M. GONZÁLEZ, T. PIERSMA, L.J. NILES, I. DE LIMA SERRANO DO NASCIMENTO, P.W. ATKINSON, N.A. CLARK, C.D.T. MINTON, M.K. PECK & G. AARTS (2004): Rapid population decline in red knots: fitness consequences of decreased refuelling rates and late arrival in Delaware Bay. *Proc. R. Soc. London B* 271: 875-882.
- BECH, M., S.B. LEONHARD & J. PEDERSEN (2004): Infauna monitoring Horns Ref offshore wind farm. Annual status report 2003. Report Bio/consult as.
- VAN DEN BERGH, L.M.J., A.L. SPAANS & N.D. VAN SWELM (2002): Lijnopstellingen van windturbines geen barrière voor voedselvluchten van meeuwen en sterns in de broedtijd. *Limosa* 75: 25-32.
- BERNDT, R., H. HECKENROTH & W. WINKEL (1979): Kriterienvorschlag für „Feuchtgebiete nationaler Bedeutung“, speziell als Rastplätze von Wasser- und Watvögeln, in der Bundesrepublik Deutschland. *Ber. Dt. Sect. Int. Rates Vogelschutz* 19: 57-62.
- BERNDT, R.K. & G. BUSCHE (1993): *Vogelwelt Schleswig-Holsteins*. Bd. 4: Entenvögel II. Karl Wachholtz Verlag, Neumünster.
- BÉTY, J., G. GAUTHIER & J.-F. GIROUX (2003): Body condition, migration, and timing of reproduction in snow geese: a test of the condition-dependent model of optimal clutch size. *Am. Nat.* 162: 110-121.
- BIRKLUND, J. & A.H. PETERSEN (2004): Development of the fouling community on turbine foundations and scour protections in Nysted Offshore Wind Farm, 2003. Report to Energi E2 A/S, DHI Water & Environment.
- BÖTTGER, M., T. CLEMENS, G. GROTHE, G. HARTMANN, E. HARTWIG, C. LAMMEN, E. VAUK-HENTZELT (1990): Biologisch-ökologische Begleituntersuchungen zum Bau und Betrieb von Windkraftanlagen. *NNA-Ber.* 3, Sonderheft: 1-124.
- BOURNE, W.R.P. (1979): Birds and gas flares. *Mar. Poll. Bull.* 10: 124-125.
- BRUNCKHORST, H. & D. MORITZ (1980): Das Vorkommen der Sturmtaucher Procellariidae und Sturmschwalben Hydrobatidae bei Helgoland. *Seevögel* 1: 49-56.
- CAMPHUYSEN, C.J., & J. VAN DIJK (1983): Zee- en kustvogels langs de Nederlandse kust, 1974-79. *Limosa* 56: 81-230.
- CAMPHUYSEN, C.J., B. CALVO, J. DURINCK, K. ENSOR, A. FOLLESTAD, R.W. FURNESS, S. GARTHE, G. LEAPER, H. SKOV, M.L. TASKER & C.J.N. WINTER (1995): Consumption of discards by seabirds in the North Sea. NIOZ-rapport 1995-5, Netherlands Institute for Sea Research, Texel.
- CAMPHUYSEN, C.J., M.S.S. LAVALEYE & M.F. LEOPOLD (1999): Vogels, zeezoogdieren en macrobenthos bij het zoekgebied voor gaswinning in mijnbouwwak Q4 (Noordzee). NIOZ-Rapport 1999-4, Netherlands Institute for Sea Research, Texel.
- CAMPHUYSEN, C.J., T.J. FOX, M.F. LEOPOLD & I.K. PETERSEN (2003): Towards standardised seabirds at sea census techniques in connection with environmental impact assessments for offshore wind farms in the U.K. NIOZ, Den Burg.
- CARLISLE, J.G., C.H. TURNER & E.E. EBERT (1964): Artificial habitat in the marine environment. *Fish Bull.* 124: 42-76.
- CHRISTENSEN, T.K. & J.P. HOUNISEN (2004): Investigations of migratory birds during operation of Horns Rev offshore wind farm: preliminary note of analysis of data from spring 2004. NERI Note commissioned by Elsam Engineering A/S.
- CHRISTENSEN, T.K. & J.P. HOUNISEN (2005): Investigations of migratory birds during operation of Horns Rev offshore wind farm. Annual status report 2004. NERI Report commissioned by Elsam Engineering A/S.
- CHRISTENSEN, T.K., I. CLAUSAGER & I.K. PETERSEN (2003): Base-line investigations of birds in relation to an offshore wind farm at Horns Rev, and results from the year of construction. NERI Report commissioned by Tech-wise A/S.

- CHRISTENSEN, T.K., J.P. HOUNISEN, I. CLAUSAGER & I.K. PETERSEN (2004): Visual and radar observations of birds in relation to collision risk at the Horns Rev offshore wind farm. Annual status report 2003. NERI Report commissioned by Elsam Engineering A/S.
- COUNCIL ON ENVIRONMENTAL QUALITY (1997): Considering cumulative effects under the National Environmental Policy Act. Council on Environmental Quality, United States.
- DESHOLM, M. (2003): Thermal Animal Detection System (TADS) – Development of a method for estimating collision frequency of migrating birds at offshore wind turbines. NERI Technical Report No. 440.
- DESHOLM, M. & J. KAHLERT (2005): Avian collision risk at an offshore wind farm. Biol. Lett. doi:10.1098/rsbl.2005.0336.
- DIEDERICHS, A., G. NEHLS & I.K. PETERSEN (2002): Flugzeugzählungen zur großflächigen Erfassung von Seevögeln und marinen Säugern als Grundlage für Umweltverträglichkeitsstudien im Offshorebereich. Seevögel 23: 38-46.
- DIERSCHKE, J. (2004): Vogelzugforschung auf der Forschungsplattform FINO I. DEWI Mag. 25: 46-47.
- DIERSCHKE, J., V. DIERSCHKE & T. KRÜGER (2005): Anleitung zur Planbeobachtung des Vogelzugs über dem Meer ("Seawatching"). Seevögel 26: 2-13.
- DIERSCHKE, V. (1987): Zum Schlafplatzverhalten der Schellente (*Bucephala clangula*) bei Schleimünde. Corax 12: 123-135.
- DIERSCHKE, V., O. HÜPPOP & S. GARTHE (2003): Populationsbiologische Schwellen der Unzulässigkeit für Beeinträchtigungen der Meeresumwelt am Beispiel der in der deutschen Nord- und Ostsee vorkommenden Vogelarten. Seevögel 24: 61-72.
- DIRKSEN, S., H. SCHEKKERMAN, J. VAN DER WINDEN, M.J.M. POOT, R. LENSINK, L.M.J. VAN DEN BERGH & A.L. SPAANS (1998a): Slaaptrek van zwarte sterns en visdieven in de omgeving van de windturbine op de sluizen van Den Oever. Bureau Waardenburg rapport 98.057. Bureau Waardenburg, Culemborg / IBN-DLO, Wageningen.
- DIRKSEN, S., A.L. SPAANS, J. VAN DER WINDEN & L.M.J. VAN DEN BERGH (1998b): Nachtelijke vliegpatronen en vlieghoogtes van duikeenden in het IJsselmeergebied. Limosa 71: 57-68.
- DIRKSEN, S., J. VAN DER WINDEN & A.L. SPAANS (1998c): Nocturnal collision risk of birds with wind turbines in tidal and semi-offshore areas. In: C.F. RATTO & G. SOLARI, Wind energy and landscape: 99-108. A.A. Balkema, Rotterdam.
- DIRKSEN, S., A.L. SPAANS & J. VAN DER WINDEN (2000): Studies on nocturnal flight paths and altitudes of waterbirds in relation to wind turbines: a review of current research in The Netherlands. In: Proc. National Avian – Wind Power Planning Meeting III, San Diego, California, May 1998: 97-109. LGL Ltd., Kong City, Canada.
- DOLMAN, P.M. & SUTHERLAND, W.J. (1995): The response of bird populations to habitat loss. Ibis 137 Suppl.: 38-46.
- DÜRR, T. (2004): Vögel als Anflugopfer an Windenergieanlagen in Deutschland – ein Einblick in die bundesweite Fundkartei. Bremer Beitr. Naturk. Naturschutz 7: 221-228.
- EBBINGE, B.S., & B. SPAANS (1995): The importance of body reserves accumulated in spring staging areas in the temperate zone for breeding in Dark-bellied Brent Geese *Branta b. bernicla* in the high Arctic. J. Avian Biol. 26: 105-113.
- EVANS, P.R. (1981): Reclamation of intertidal land: some effects on Shelduck and wader populations in the Tees estuary. Verh. ornithol. Ges. Bayern 23: 147-168.
- EVERAERT, J. (2003): Windturbines en vogels in Vlaanderen: voorlopige onderzoeksresultaten en aanbevelingen. Natuur.Oriolus 69: 145-155.
- EVERAERT, J., K. DEVOS & E. KUIJKEN (2002): Windturbines en vogels in Vlaanderen. Rapport Inst. Natuurbehoud 2002.3, Brussel.
- EXO, K.-M., O. HÜPPOP & S. GARTHE (2002): Offshore-Windenergieanlagen und Vogelschutz. Seevögel 23: 83-95.
- FURNESS, R.W. (2003): Impacts of fisheries on seabird communities. Sci. Mar. 67, Suppl. 2: 33-45.
- FURNESS, R.W. & D.M. BRYANT (1996): Effect of wind on field metabolic rates of breeding Northern Fulmars. Ecology 77: 1181-1188.
- FURNESS, R.W., & M.L. TASKER (2000): Seabird-fishery interactions: quantifying the sensitivity of seabirds to reductions in sandeel abundance, and identification of key areas for sensitive seabirds in the North Sea. Mar. Ecol. Prog. Ser. 202: 253-264.

- GANTER, B., P. PROKOSCH & B.S. EBBINGE (1997): Effect of saltmarsh loss on the dispersal and fitness parameters of Dark-bellied Brent Geese. *Aquatic Conserv. Mar. Freshw. Ecosyst.* 7: 141-151.
- GARTHE, S. (2000): Mögliche Auswirkungen von Offshore-Windenergieanlagen auf See- und Wasservögel der deutschen Nord- und Ostsee. In: MERCK, T. & H. VON NORDHEIM (eds.): Technische Eingriffe in marine Lebensräume: 113-119. BfN-Skripten 29, Bundesamt für Naturschutz, Bonn – Bad Godesberg.
- GARTHE, S. (2003): Verteilungsmuster und Bestände von Seevögeln in der Ausschließlichen Wirtschaftszone (AWZ) der deutschen Nord- und Ostsee und Fachvorschläge für EU-Vogelschutzgebiete. *Ber. Vogelschutz* 40: 15-56.
- GARTHE, S. & O. HÜPPOP (1994): Distribution of ship-following seabirds and their utilization of discards in the North Sea in summer. *Mar. Ecol. Prog. Ser.* 106: 1-9.
- GARTHE, S. & O. HÜPPOP (2004): Scaling possible adverse effects of marine wind farms on seabirds: developing and applying a vulnerability index. *J. Appl. Ecol.* 41: 724-734.
- GARTHE, S., T. FREYER, O. HÜPPOP & D. WÖLKE (1999): Breeding Lesser Black-backed Gulls *Larus graellsii* and Herring Gulls *Larus argentatus*: coexistence or competition? *Ardea* 87: 227-236.
- GARTHE, S., O. HÜPPOP & T. WEICHLER (2002): Anleitung zur Erfassung von Seevögeln auf See von Schiffen. *Seevogel* 23: 47-55.
- GARTHE, S., T. KRÜGER, U. KUBETZKI & T. WEICHLER (2003a): Monitoring von Seevögeln auf See: Gegenwärtiger Stand und Perspektiven. *Ber. Landesamtes Umweltsch. Sachsen-Anhalt, Sonderheft 1/2003*: 62-64.
- GARTHE, S., N. ULLRICH, T. WEICHLER, V. DIERSCHKE, U. KUBETZKI, J. KOTZERKA, T. KRÜGER, N. SONNTAG & A.J. HELBIG (2003b): See- und Wasservögel der deutschen Ostsee. Verbreitung, Gefährdung und Schutz. Bundesamt für Naturschutz, Bonn-Bad Godesberg.
- GARTHE, S., V. DIERSCHKE, T. WEICHLER & P. SCHWEMMER (2004): Teilprojekt 5 - Rastvogelvorkommen und Offshore-Wind-kraftnutzung: Analyse des Konfliktpotenzials für die deutsche Nord- und Ostsee. In: A. KELLERMANN *et al.* (eds.): *Marine Warmblüter in Nord- und Ostsee: Grundlagen zur Bewertung von Windkraftanlagen im Offshore-Bereich. Endbericht.*
- GOSS-CUSTARD, J.D. (1979): Effect of habitat loss on the numbers of overwintering shorebirds. *Stud. Avian Biol.* 2: 167-177.
- GOSS-CUSTARD, J.D. (1985): Foraging behaviour of wading birds and the carrying capacity of estuaries. In: R.M. Sibly & R.H. Smith, *Behavioural ecology: ecological consequences of adaptive behaviour*: 169-188, Oxford.
- GREEN, R.H. (1979): *Sampling design and statistical methods for environmental biologists.* Wiley Interscience, Chichester.
- GRÜNKORN, T., A. DIEDERICHS, B. STAHL, D. POSZIG & G. NEHLS (2005): Entwicklung einer Methode zur Abschätzung des Kollisionsrisikos von Vögeln an Windenergieanlagen. Report to Landesamt für Natur und Umweltschutz Schleswig-Holstein, BioConsult SH, Hockensbüll.
- GRUNSKY-SCHÖNEBERG, B. (1998): Brutbiologie und Nahrungsökologie der Trottellumme (*Uria aalge* Pont.) auf Helgoland. *Ökol. Vogel* 20: 217-274.
- GUILLEMETTE, M., J.K. LARSEN & I. CLAUSAGER (1998): Impact assessment of an off-shore wind park on sea ducks. NERI Technical Report No 227, National Environmental Research Institute.
- GUILLEMETTE, M., J.K. LARSEN & I. CLAUSAGER (1999): Assessing the impact of the Tunø Knob wind park on sea ducks: the influence of food resources. NERI Technical Report No 263, National Environmental Research Institute.
- HAUGE, F. & S. FOLKEDAL (1980): Høsttrekket av fugl ved Ekofiskfeltet i Nordsjøen 1978. *Vår Fuglefauna* 3: 220-226.
- HELBIG, A., V. RIEHL & J. VOSS (1979): Ornithologische Beobachtungen im Frühjahr 1977 auf der Forschungsplattform „Nordsee“. *Abh. Geb. Vogelk.* 6: 215-247.
- HELBIG, A.J., V. DIERSCHKE & I. SEIBOLD (1996): Ornithologischer Jahresbericht 1995 für Hiddensee und Umgebung. *Ber. Vogelwarte Hiddensee* 13: 61-96.
- HÖLZINGER, J., G. KNÖTZSCH, S. SCHUSTER & K. WESTERMANN (1972): Wetlands (Feuchtgebiete) in Baden-Württemberg mit internationaler und nationaler Bedeutung für Wasservögel. *Anz. ornithol. Ges. Bayern* 11: 70-110.



- HÖTKER, H., K.-M. THOMSEN & H. KÖSTER (2004): Auswirkungen regenerativer Energiegewinnung auf die biologische Vielfalt am Beispiel der Vögel und der Fledermäuse – Fakten, Wissenslücken, Anforderungen an die Forschung, ornithologische Kriterien zum Ausbau von regenerativen Energiegewinnungsformen. Michael-Otto-Institut im NABU, Bergenhusen.
- HÜPPOP, O., H. BALLASUS, F. FIEßER, M. REBKE & F. STOLZENBACH (2005): AWZ-Vorhaben: Analyse- und Bewertungsmethoden von kumulativen Auswirkungen von Offshore-WEA auf den Vogelzug (FKZ 804 85 004). Abschlussbericht. Bundesamt für Naturschutz.
- HÜPPOP, O., S. GARTHE, E. HARTWIG & U. WALTER (1994): Fischerei und Schiffsverkehr: Vorteil oder Problem für See- und Küstenvögel? In: J.L. LOZÁN, E. RACHOR, K. REISE, H. VON WESTERNHAGEN & W. LENZ (eds.): Warnsignale aus dem Wattenmeer: 278-285. Blackwell Wissenschafts-Verlag, Berlin.
- IMBER, M. (1975): Behavior of petrels in relation to the moon and artificial lights. *Notornis* 22: 302-306.
- JACOBS, J. (1974): Quantitative measurement of food selection. *Oecologia* 14: 413-417.
- JENSEN, H., P.S. KRISTENSEN & E. HOFFMANN (2004): Sandeels in the wind farm area at Horns Reef. Report to Elsam, Danish Institute for Fisheries Research, Charlottenlund.
- JONES, P.H. (1980): The effect on birds of a North Sea gas flare. *Brit. Birds* 73: 547-555.
- KAHLERT, J., M. DESHOLM & I. CLAUSAGER (2004a): Investigations of migratory birds during operation of Nysted offshore wind farm at Rødsand: preliminary analysis of data from spring 2004. NERI Note commissioned by Energi E2.
- KAHLERT, J., I.K. PETERSEN, A.D. FOX, M. DESHOLM & I. CLAUSAGER (2004b): Investigations of birds during construction and operation of Nysted offshore wind farm at Rødsand. Annual status report 2003. NERI Report commissioned by Energi E2 A/S.
- KAISER, M.J. (2004): Predicting the displacement of common scoter *Melanitta nigra* from benthic feeding areas due to offshore windfarms. COWRIE-BEN-03-2002 interim report 2004-4.
- KRAPU, G.L. (1981): The role of nutrient reserves in Mallard reproduction. *Auk* 98: 29-38.
- KRÜGER, T., & S. GARTHE (2002): Das Vorkommen ausgewählter See- und Küstenvögel vor Wangerooge während des Wegzugs: der Einfluß von Windrichtung und -stärke. *J. Ornithol.* 143: 155-170.
- KUBE, J. (1996): The ecology of macrozoobenthos and sea ducks in the Pomeranian Bay. *Meereswiss. Ber.* 18: 1-128.
- LAMBECK, R.H.D. (1991): Changes in abundance, distribution and mortality of wintering Oystercatchers after habitat loss in the Delta area, SW Netherlands. *Acta XX. Congr. Int. Ornithol.*: 2208-2218, Wellington.
- LEIPE, T. (1985): Zur Nahrungsökologie der Eisente (*Clangula hyemalis*) im Greifswalder Bodden. *Beitr. Vogelk.* 31: 121-140.
- LEMMING, J. (1999): A Danish perspective on offshore wind farms. In: *Irish Sea Renewable Energy Resources*: 33-42. Irish Sea Forum Report No. 23.
- LEONHARD, S.B. & J. PEDERSEN (2004): Hard bottom substrate monitoring Horns Rev offshore wind farm. Annual status report 2003. Report Bio/consult as.
- MADSEN, J. (1995): Impacts of disturbance of migratory waterfowl. *Ibis* 137, Suppl.: 67-74.
- MEEK, E.R., J.B. RIBBANDS, W.B. CHRISTER, P.R. DAVY & I. HIGGINSON (1993): The effects of aerogenerators on moorland bird populations in the Orkney Islands, Scotland. *Bird Study* 40: 140-143.
- MELTOFTE, H., & T. KIØRBOE (1973): Forekomsten af lommer *Gaviidae* ve Blåvandshuk 1963-1971. *Dansk Ornithol. Foren. Tidsskr.* 67: 109-114.
- MITSCHE, A., S. GARTHE & O. HÜPPOP (2001): Erfassung der Verbreitung, Häufigkeiten und Wanderungen von See- und Wasservögeln in der deutschen Nordsee. *BfN-Skripten* 34, Bonn-Bad Godesberg.
- MÜLLER, H.H. (1981): Vogelschlag in einer starken Zugnacht auf der Off-shore-Forschungsplattform „Nordsee“ im Oktober 1979. *Seevögel* 2: 33-37.
- MUSTERS, C.J.M., M.A.W. NOORDERVLIET & W.J. TER KEURS (1996): Bird casualties caused by a wind energy project in an estuary. *Bird Study* 43: 124-126.
- NEHLS, G. (1989): Occurrence and food consumption of the common eider, *Somateria mollissima*, in the Wadden Sea of Schleswig-Holstein. *Helgoländer Meeresunters.* 43: 385-393.
- NELSON, J.B. (2002): *The Atlantic Gannet*. 2nd edn. Fenix Books, Great Yarmouth.
- NERI (NATIONAL ENVIRONMENTAL RESEARCH INSTITUTE) (2000): Offshore wind farms. Proposals for criteria for acceptable impacts on bird populations. National Environmental Research Institute, Kalø.

- NOER, H., T.K. CHRISTENSEN, I. CLAUSAGER & I.K. PETERSEN (2000): Effects on birds of an offshore wind park at Horns Rev: Environmental impact assessment. NERI Report.
- ORTEGO, B. (1978): Blue-faced Boobies at an oil production platform. *Auk* 95: 762-763.
- PAINTER, A., B. LITTLE & S. LAWRENCE (1999): Continuation of bird studies at Blyth Harbour wind farm and the implications for offshore wind farms. ETSU Report W/13/00485/00/00.
- PEARSON, T.H. (1968): The feeding biology of sea-bird species breeding on the Farne Islands, Northumberland. *J. Anim. Ecol.* 37: 521-552.
- PERCIVAL, S.M. (2001): Assessment of the effects of offshore wind farms on birds. ETSU Report W/13/00565/REP, DTI/PubURN01/1434.
- PERCIVAL, S. (2005): Birds and windfarms: what are the real issues? *Brit. Birds* 98: 194-204.
- PETERSEN, I.K. (2004): Investigation of birds during the operational phase of the Nysted offshore wind farm. Preliminary notes on the issue of potential habitat loss. National Environmental Research Institute.
- PETERSEN, I.K. (2005): Bird numbers and distribution in the Horns Rev offshore wind farm area. Annual status report 2004. NERI Report commissioned by Elsam Engineering A/S.
- PETERSEN, I.K., I. CLAUSAGER & T.K. CHRISTENSEN (2004): Bird numbers and distribution in the Horns Rev offshore wind farm area. Annual status report 2003. NERI Report commissioned by Elsam Engineering A/S.
- PETTERSSON, J. (2001): Bird observation in southern Kalmar Sound. Autumn/early winter 2000. Report requested by Vindkompaniet AB and Enron Wind.
- PETTERSSON, J. (2002): Bird observation in southern Kalmar Sound. Spring and autumn 2001. Report requested by Vindkompaniet AB and Enron Wind Sverige.
- PETTERSSON, J. (2003): Bird observation in southern Kalmar Sound. Spring and autumn 2002. Report requested by GE Energy and Vindkompaniet AB.
- PETTERSSON, J. (2005): The impact of offshore wind farms on bird life in southern Kalmar Sound, Sweden. Report requested by Swedish Energy Agency.
- PETTERSSON, J. & T. STALIN (2002): Influence of offshore windmills on migration birds in southeast coast of Sweden. Unpubl. report to GE Wind Energy.
- PFEIFER, G. (2003): Die Vögel der Insel Sylt. Husum Druck- und Verlagsgesellschaft, Husum.
- PROP, J., J.M. BLACK & P. SHIMMINGS (2003): Travel schedules to the high arctic: barnacle geese trade-off the timing of migration with accumulation of fat deposits. *Oikos* 103: 403-414.
- REBKE, M. (2005): Populationsmodelle zur Abschätzung der Auswirkungen additiver Vogelmortalität an Offshore-Windenergieanlagen. Diplomarb. Univ. Bremen.
- SAGE, B. (1979): Flare up over North Sea birds. *New Scientist* 81: 464-466.
- SCHERNER, E.R. (1999): Windkraftanlagen und „wertgebende Vogelbestände“ bei Bremerhaven: Realität und Realsatire? *Beitr. Naturk. Niedersachsens* 52: 121-156.
- SCHIRMEISTER, B. (2001): Ungewöhnliche Ansammlungen der Zwergmöwe *Larus minutus* in der Pommerschen Bucht vor Usedom im Spätsommer 2000. *Ornithol. Rundbr. Mecklenburg-Vorpommern* 43: 35-48.
- SCHIRMEISTER, B. (2002): Durchzug und Rast der Zwergmöwe *Larus minutus* in der Pommerschen Bucht vor Usedom in den Jahren 2001 und 2002. *Ornithol. Rundbr. Mecklenburg-Vorpommern* 44: 34-46.
- SMITH, R.J., & F.R. MOORE (2003): Arrival fat and reproductive performance in a long-distance passerine migrant. *Oecologia* 134: 325-331.
- SMITH, R.J., & F.R. MOORE (2005): Arrival timing and seasonal reproductive performance in a long-distance migratory landbird. *Behav. Ecol. Sociobiol.* 57: 231-239.
- STILL, D., B. LITTLE & S. LAWRENCE (1996): The effect of wind turbines on the bird population at Blyth Harbour. ETSU Report W/13/00394/REP.
- STOCK, M., & F. HOFEDITZ (1996): Zeit-Aktivitäts-Budgets von Ringelgänsen (*Branta bernicla bernicla*) in unterschiedlich stark von Menschen beeinflussten Salzwiesen des Wattenmeeres. *Vogelwarte* 38: 121-145.
- STOCK, M., & F. HOFEDITZ (1997): Grenzen der Kompensation: Energiebudgets von Ringelgänsen (*Branta b. bernicla*) - die Wirkung von Störreizen. *J. Ornithol.* 138: 387-411.

- STRUWE-JUHL, B. (2000): Zur Bedeutung ausgewählter Gewässer des östlichen Schleswig-Holstein für rastende Wasservögel – Vergleichende Auswertung der Ergebnisse der Internationalen Wasservogelzählung aus den Jahren 1966/67-1995/96. *Corax* 18, Sonderheft 1: 1-240.
- SUTHERLAND, W.J., & J.D. GOSS-CUSTARD (1991): Predicting the consequences of habitat loss on shorebird populations. *Acta XX. Congr. Int. Ornithol.*: 2199-2207, Wellington.
- TASKER, M.L., P.H. JONES, T.J. DIXON & B.F. BLAKE (1984): Counting seabirds at sea from ships: a review of methods employed and a suggestion for a standardized approach. *Auk* 101: 567-577.
- TASKER, M.L., P.H. JONES, B.F. BLAKE, T.J. DIXON & A.J. WALLIS (1986): Seabirds associated with oil production platforms in the North Sea. *Ringling & Migration* 7: 7-14.
- TINGLEY, M.W. (2003): Effects of offshore wind farms on birds. Thesis Harvard University Cambridge, Massachusetts.
- TOUGAARD, J., J. CARSTENSEN, O.D. HENRIKSEN, J. TEILMANN & J.R. HANSEN (2004): Harbour Porpoises on Horns Reef – effects of the Horns Reef Wind Farm. Annual status report 2003. NERI Technical Report.
- TULP, I., H. SCHEKKERMAN, J.K. LARSEN, J. VAN DER WINDEN, R.J.W. VAN DE HATERD, P. VAN HORSSSEN, S. DIRKSEN & A.L. SPAANS (1999): Nocturnal flight activity of sea ducks near the windfarm Tunø Knob in the Kattegat. Bureau Waardenburg report nr. 99.64.
- WALLIS, A. (1981): North Sea gas flares. *Brit. Birds* 74: 536-537.
- WESTERBERG, H. (2000): Impact studies of sea-based windpower in Sweden. In: MERCK, T. & H. VON NORDHEIM (eds.): Technische Eingriffe in marine Lebensräume: 163-168. BfN-Skripten 29, Bundesamt für Naturschutz, Bonn – Bad Godesberg.
- WIESE, F.K., W.A. MONTEVECCHI, G.K. DAVOREN, F. HUETTMANN, A.W. DIAMOND & J. LINKE (2001): Seabirds at risk around offshore oil platforms in the north-west Atlantic. *Mar. Poll. Bull.* 42: 1285-1290.
- VAN DER WINDEN, J., H. SCHEKKERMAN, I. TULP & S. DIRKSEN (2000): The effects of offshore windfarms on birds. In: MERCK, T. & H. VON NORDHEIM (Hrsg.): Technische Eingriffe in marine Lebensräume: 126-135. BfN-Skr. 29, Bundesamt für Naturschutz, Bonn-Bad Godesberg.
- WINKELMAN, J.E. (1989): Vogels en het windpark nabij Urk (NOP): aanvaringslachtoffers en verstoring van pleisterende eenden ganzen en zwanen. RIN-rapport 89/15. Rijksinstituut voor Natuurbeheer, Arnhem.
- WINKELMAN, J.E. (1992a): De invloed van de Sep-proefwindcentrale te Oosterbierum (Fr.) op vogels, 1: aanvaringslachtoffers. RIN-rapport 92/2. IBN-DLO, Arnhem.
- WINKELMAN, J.E. (1992b): De invloed van de Sep-proefwindcentrale te Oosterbierum (Fr.) op vogels, 2: nachtelijke aanvaringskansen. RIN-rapport 92/3. IBN-DLO, Arnhem.
- WINKELMAN, J.E. (1992c): De invloed van de Sep-proefwindcentrale te Oosterbierum (Fr.) op vogels, 3: aanvliegedrag overdag. RIN-rapport 92/4. IBN-DLO, Arnhem.
- WOLFSON, A., G. VAN BLARICOM, N. DAVIS & G.S. LEWBEL (1979): The marine life of an offshore oil platform. *Mar. Ecol. Prog. Ser.* 1: 81-89.
- WRIGHT, P.J., H. JENSEN & I. TUCK (2000): The influence of sediment type on the distribution of the lesser sandeel, *Ammodytes marinus*. *J. Sea Res.* 44: 243-256.

## APPENDIX I

Systematic list of species mentioned in this report (English name – scientific name – German name)

Red-throated Diver – *Gavia stellata* – Sterntaucher  
 Black-throated Diver – *Gavia arctica* – Prachttaucher  
 Red-necked Grebe – *Podiceps grisegena* – Rothalstaucher  
 Great Crested Grebe – *Podiceps cristatus* – Haubentaucher  
 Slavonian Grebe – *Podiceps auritus* – Ohrentaucher  
 (Northern) Fulmar – *Fulmarus glacialis* – Eissturmvogel  
 Sooty Shearwater – *Puffinus griseus* – Dunkler Sturmtaucher  
 Storm Petrel – *Hydrobates pelagicus* – Sturmschwalbe  
 Leach's Storm-petrel – *Oceanodrom leucorhoa* – Wellenläufer  
 (Northern) Gannet – *Morus bassanus* – Basstölpel  
 (Great) Cormorant – *Phalacrocorax carbo* – Kormoran  
 (European) Shag – *Phalacrocorax aristotelis* – Krähenscharbe  
 Pink-footed Goose – *Anser brachyrhynchus* – Kurzschnabelgans  
 Snow Goose – *Anser caerulescens* – Schneegans  
 Barnacle Goose – *Branta leucopsis* – Weißwangengans  
 Brent Goose – *Branta bernicla* – Ringelgans  
 Shelduck – *Tadorna tadorna* – Brandgans  
 Gadwall – *Anas strepera* – Schnatterente  
 (Eurasian) Teal – *Anas crecca* – Krickente  
 Mallard – *Anas platyrhynchos* – Stockente  
 (Northern) Shoveler – *Anas clypeata* – Löffelente  
 Pochard – *Aythya ferina* – Tafelente  
 Tufted Duck – *Aythya fuligula* – Reiherente  
 Greater Scaup – *Aythya marila* – Bergente  
 (Common) Eider – *Somateria mollissima* – Eiderente  
 Long-tailed Duck – *Clangula hyemalis* – Eisente  
 Common Scoter – *Melanitta nigra* – Trauerente  
 Velvet Scoter – *Melanitta fusca* – Samtente  
 Red-breasted Merganser – *Mergus serrator* – Mittelsäger  
 (Northern) Lapwing – *Vanellus vanellus* – Kiebitz  
 Red Knot – *Calidris canutus* – Knutt  
 Pomarine Skua – *Stercorarius pomarinus* – Spatelraubmöwe  
 Arctic Skua – *Stercorarius parasiticus* – Schmarotzerraubmöwe  
 Great Skua – *Catharacta skua* – Skua  
 Little Gull – *Larus minutus* – Zwergmöwe  
 Black-headed Gull – *Larus ridibundus* – Lachmöwe  
 Common Gull – *Larus canus* – Sturmmöwe  
 Lesser Black-backed Gull – *Larus fuscus* – Heringsmöwe  
 Herring Gull – *Larus argentatus* – Silbermöwe  
 Great Black-backed Gull – *Larus marinus* – Mantelmöwe  
 Sabine's Gull – *Xema sabini* – Schwalbenmöwe  
 (Black-legged) Kittiwake – *Rissa tridactyla* – Dreizehenmöwe  
 Caspian Tern – *Sterna caspia* – Raubseeschwalbe  
 Sandwich Tern – *Sterna sandvicensis* – Brandseeschwalbe  
 Little Tern – *Sterna albifrons* – Zwergseeschwalbe  
 Common Tern – *Sterna hirundo* – Flusseeeschwalbe  
 Arctic Tern – *Sterna paradisaea* – Küstenseeschwalbe  
 Black Tern – *Chlidonias niger* – Trauerseeschwalbe  
 (Common) Guillemot – *Uria aalge* – Trottellumme  
 Razorbill – *Alca torda* – Tordalk  
 Black Guillemot – *Cephus grylle* – Gryllteiste  
 Little Auk – *Alle alle* – Krabbentaucher  
 Puffin – *Fratercula arctica* – Papageitaucher

# Literature Review of Offshore Wind Farms with Regard to Marine Mammals

Klaus Lucke<sup>1,\*</sup>, Sandra Storch<sup>2</sup>, Justin Cooke<sup>3</sup> & Ursula Siebert<sup>1</sup>

1 FTZ Westküste, University of Kiel, Hafentörn 1, 25761Büsum

2 WortWahl, Schwartenbeker Weg 67, 24107 Kiel

3 Centre for Ecosystem Management Studies, Alexanderstr. 10, 79261 Gutach

\*corresponding author: lucke@ftz-west.uni-kiel.de

## Contents

<b>List of Figures</b> .....	<b>201</b>
<b>List of Tables</b> .....	<b>203</b>
<b>1 Summary</b> .....	<b>204</b>
<b>2 Zusammenfassung</b> .....	<b>205</b>
<b>3 Introduction</b> .....	<b>207</b>
<b>4 Objectives of the Present Report</b> .....	<b>208</b>
<b>5 Marine Mammals in German Waters</b> .....	<b>208</b>
<b>5.1 Cetaceans</b> .....	<b>208</b>
5.1.1 Harbour Porpoises ( <i>Phocoena phocoena</i> ) .....	209
<b>5.2 Pinnipeds</b>	
5.2.1 Harbour Seals ( <i>Phoca vitulina</i> ).....	209
5.2.2 Grey Seals ( <i>Halichoerus grypus</i> ).....	210
<b>6 Bioacoustics of Marine Mammals – Progress in Knowledge</b> .....	<b>211</b>
<b>6.1 Vocalisations of Marine Mammals</b> .....	<b>211</b>
<b>6.2 Hearing in Marine Mammals</b> .....	<b>212</b>
6.2.1 General Effects of Underwater Noise on Marine Mammals.....	212
6.2.2 Anatomy of the Ear.....	213
6.2.3 Hearing Thresholds and Audiograms .....	213
6.2.4 Masking.....	215
<b>6.3 Sound Induced Temporary Threshold Shift (TTS) in Marine Mammals and Definition of Marine Mammal Safety Zones (MMSZ)</b> .....	<b>216</b>
<b>6.4 Sound Levels in Perception Units: dBht (Species)</b> .....	<b>217</b>
<b>7 Measurement of Background Noise Levels and Propagation Losss</b> .....	<b>218</b>
<b>8 Site Investigation for Offshore Wind Farm Construction: Noise Emitted and Effects on Marine Mammals</b> .....	<b>219</b>
<b>8.1 Airgun/Seismic Studies</b> .....	<b>219</b>
<b>8.2 SONAR</b> .....	<b>224</b>

<b>9</b>	<b>Construction of Offshore Wind Farms: Noise Emitted and Effects on Marine Mammals</b> .....	<b>226</b>
9.1	<b>Noise Measurements</b> .....	<b>227</b>
9.2	<b>Effects on Marine Mammals</b> .....	<b>230</b>
<b>10</b>	<b>Other Offshore Construction: Noise Emitted and Effects on Marine Mammals</b> .....	<b>234</b>
10.1	<b>Pile Driving Activities</b> .....	<b>235</b>
10.2	<b>Dredging</b> .....	<b>241</b>
10.3	<b>Drilling</b> .....	<b>243</b>
<b>11</b>	<b>Operation of Offshore Wind Turbines: Noise Emitted and Effects on Marine Mammals</b> .....	<b>244</b>
11.1	<b>Noise Measurements</b> .....	<b>244</b>
11.2	<b>Effects on Marine Mammals</b> .....	<b>252</b>
<b>12</b>	<b>Removal of Offshore Wind Farms and Other Structures after Decommissioning: Noise Emitted and Effects on Marine Mammals</b> .....	<b>256</b>
<b>13</b>	<b>Boat Noise and Effects on Marine Mammals</b> .....	<b>257</b>
<b>14</b>	<b>Mitigation Measures to Reduce Acoustic Impact on Marine Mammals</b> .....	<b>262</b>
14.1	<b>Acoustic Harassment Devices (AHD)</b> .....	<b>262</b>
14.2	<b>Soft-Start Procedure</b> .....	<b>263</b>
14.3	<b>Bubble Curtains</b> .....	<b>263</b>
14.4	<b>Isolation Piles</b> .....	<b>265</b>
14.5	<b>Other Sound Mitigation Measures</b> .....	<b>265</b>
<b>15</b>	<b>Conclusions – Progress and Research Needs</b> .....	<b>266</b>
<b>16</b>	<b>Modelling the Effects of Offshore Wind Farms on Harbour Porpoise Populations: Parameters, Model Structure, Scale and Needed Data</b> .....	<b>269</b>
16.1	<b>Factors Included in the Model</b> .....	<b>269</b>
16.2	<b>Spatial and Temporal Scales For Assessment</b> .....	<b>270</b>
16.3	<b>Modelling of Wind Turbine Effects: Preliminary Considerations</b> .....	<b>272</b>
16.4	<b>Model Structure and Input Data</b> .....	<b>272</b>
16.4.1	<b>Population Identity</b> .....	<b>272</b>
16.4.2	<b>Population Dynamics</b> .....	<b>273</b>
16.4.3	<b>Modelling the Distribution of Porpoises</b> .....	<b>274</b>
16.4.4	<b>Modelling the Effects of Offshore Wind Turbines</b> .....	<b>275</b>
16.4.5	<b>Modelling the Population Consequences of Offshore Wind Turbine Impacts</b> .....	<b>276</b>
16.4.6	<b>Data Requirements</b> .....	<b>276</b>
<b>17</b>	<b>References</b> .....	<b>278</b>

## List of Figures

Fig. 1:	Absolute hearing thresholds of two grey seals ( <i>Halichoerus grypus</i> ) in water, obtained by AEP technology (from RIDGWAY & JOYCE 1975).....	214
Fig. 2:	Absolute hearing thresholds of harbour seals ( <i>Phoca vitulina</i> ) in air achieved in different studies by using behavioural and electro-physiological methods (AEP) (MINOS: Lucke <i>et al.</i> 2004). .....	214
Fig. 3:	Absolute hearing thresholds of harbour porpoises ( <i>Phocoena phocoena</i> ) achieved in different studies using behavioural and physiological methods (AEP) (MINOS: Lucke <i>et al.</i> 2004).....	215
Fig. 4:	Typical spectrum of the sound signal received during an impulse from the airgun array at 3000 m distance and 10 m depth (from: NEDWELL <i>et al.</i> 1999). .....	222
Fig. 5:	Peak sound pressure level in dB re 1 $\mu$ Pa vs. distance from seismic array. The measurements were taken at 5 m depth (from: NEDWELL <i>et al.</i> 1999). ....	223
Fig. 6a:	Harbour porpoise sighting rates near the Small Isles before, during and after the 1999 Joint Maritime Course (from: PARSONS <i>et al.</i> 2000). .....	225
Fig. 6b:	Harbour porpoise sighting rates in Gairloch before, during and after the 1998 Joint Maritime Course. (from: PARSONS <i>et al.</i> 2000). .....	225
Fig. 7:	Harbour seal and California sea lion ( <i>Zalophus californianus</i> ) haul-out sites and feeding areas in the San Francisco Bay area (from CALTRANS 2001). The location of the San Francisco-Oakland Bay Bridge (SFOBB, black line) and the Pile Installation Demonstration Project (PIDP) is marked by the big arrow. ....	236
Fig. 8:	The PVE 2316 VM driver used for vibratory pile driving (from: Nedwell <i>et al.</i> 2003b). .....	240
Fig. 9:	A typical sound pressure level vs. time history obtained at a distance of 417 m from the piling during the use of a vibratory driving device. Times of active vibratory pile driving are marked black, arrows show boat passages and noise during the measurements (after: NEDWELL <i>et al.</i> 2003b). .....	241
Fig. 10:	Underwater noise emitted from a single offshore turbine (450 kW) at Vindeby and respective background noise. Levels are recorded at a distance of 14 m from the turbine and are plotted in $1/3$ octave bands with linear averaging over 4 to 5 minutes (from: DEGN 2000). .....	245
Fig. 11:	Underwater noise emitted from a single offshore turbine (550 kW) at Gotland and respective background noise. Levels are recorded at a distance of 20 m from the turbine and are plotted in $1/3$ octave bands with linear averaging over 4 to 5 minutes (from: DEGN 2000). .....	245
Fig. 12:	Estimated underwater noise level of a hypothetical 2 MW offshore wind turbine at a distance of 20 m and a wind speed of 8 m/s, with a concrete foundation (green line), and as a steel monopile (red line). See text for calculation basis. Average hearing thresholds, taken from RICHARDSON <i>et al.</i> (1995), are given as grey marks for comparison (from: DEGN 2000). ....	246

Fig. 13: Spectrum of noise levels at the four different distances of hydroacoustic measurements performed at Bockstigen No. 1 during operation. The wind speed was 4 to 5 m/s. (from: FRISTED <i>et al.</i> 2001).....	247
Fig. 14: Locations of the seven 1.5 MW turbines and three hydrophones at Utgrunden wind farm (from: INGEMANSSON TECHNOLOGY 2003). .....	248
Fig. 15: Sound measured at turbine 4 at high wind conditions (11 to 14 m/s, east) plotted for the different hydrophone positions 463 m, 160 m and 83 m distance (from: INGEMANSSON TECHNOLOGY 2003). .....	249
Fig. 16: Received sound levels ( $1/3$ octave plot) recorded at hydrophone location 3 (83 m distance to wind turbine) at different wind speeds of 4, 8 and 14 m/s (from: INGEMANSSON TECHNOLOGY AB 2003).....	250
Fig. 17: Underwater sound emitted from a 1.5 MW offshore turbine at Utgrunden, Sweden, at various wind speeds ( $1/3$ octave band spectrum). Only one turbine was operating during measurement. At background noise recording, no turbines were running (from: DEWI 2004). .....	251
Fig. 18: Spectrum of sound pressure emitted from a hypothetical 4.5 MW offshore wind turbine during operation at a distance of 10 m, estimated using a numeric model and averaged over the water depth (from: DEWI 2004).....	251
Fig. 19: Source sound levels of offshore wind turbines (coloured bars) and background noise levels (grey bars) converted for direct comparability to worst-case audiograms (see text) of harbour porpoise and seals (lines) (from: HENRIKSEN <i>et al.</i> 2001). .....	254
Fig. 20: Summary of representative underwater noise spectra for different noise attenuation systems used during the PIDP. Black line: no attenuation; red line: single layered, unconfined bubble curtain; green dotted line: fabric barrier system – non aerated; green line: aerated fabric barrier system (from: ILLINGWORTH & RODKIN 2001).....	264



## List of Tables

Table 1:	Specification of tests conducted in the course of the BROMMAD study (after: THOMPSON 1998).....	220
Table 2:	Frequency ranges and average source levels of different sonar applications (from: PARSONS <i>et al.</i> 2000, see literature cited therein).....	224
Table 3:	Foundation types used for offshore wind turbines, dimensions and sequence of installation tasks (from: OFFSHOREWINDENERGY 2004, <a href="http://www.offshorewindenergy.org">http://www.offshorewindenergy.org</a> ).....	226
Table 4:	Sound pressure levels measured during ramming activities of pile 1 during the PIDP (units in dB re 1 $\mu$ Pa), applying a hammer energy between 900 and 1300 kJ.....	235
Table 5:	Number of marine mammals observed in the water during the construction period for the PIDP. ....	237
Table 6:	Numbers of marine mammals observed during the construction of the eastbound structure of the SFOBB. Distances given refer to distance from the site of pile driving. ....	239
Table 7:	Distances of measurement locations from piling site (from: NEDWELL <i>et al.</i> 2003b).....	239
Table 8:	Specification of piles, driving techniques and distance of sound level measurements from piling site (from: NEDWELL <i>et al.</i> 2003b); vibro = vibratory pile driving, impact = impact pile driving. ....	240
Table 9:	Impacts that could affect marine mammals directly or indirectly during or after underwater dredging activities. ....	242
Table 10:	The three hydrophones deployed at Utgrunden: distances to turbine 4 and water depths (after: INGEMANSSON TECHNOLOGY 2003) .....	248
Table 11:	Attenuation per doubled distance at different frequencies and hydrophone locations (after: INGEMANSSON TECHNOLOGY AB 2003). ....	249

## 1 Summary

Offshore wind farm development has kept up its momentum in recent years. In Germany all projects – except a few which have been rejected by the authorising agency – have been continued, while internationally, an increasing number of wind farms are planned, and a few have even been already installed. Progress has also been made with regard to the studies on the potential impact of offshore wind turbines on the marine environment in general and marine mammals in particular. This report summarises the available information on the latter, and discusses the extent and quality of the data to the extent possible.

The main focus has been placed on the acoustic effects of wind turbine related sound emissions on the three marine mammal species abundant in the German waters, harbour porpoises, harbour seals and grey seals. This includes on the one hand data on sound emissions from wind turbines and on the other, information on its biological impact on the animals. Since the potential impact of acoustic emissions on marine mammals is a complex issue in any case, and since relevant knowledge in many areas is insufficient or non-existent, a useful way to proceed is to build theoretical models of the effects. As a first step, a compilation of the non-acoustical parameters which must be known for such a model is included in this report.

The results of the Danish studies clearly indicate that the construction of wind turbines has an immediate negative effect on the abundance of harbour porpoises and their habitat use in the wind farm areas. It remains unclear which factors would explain for the differences found between the effects documented at the two large Danish wind farms and for how long these effects will last. Given the yet-inconclusive results, any transfer of conclusions on the effects of the construction – except for the immediate effects of the pile driving – from one wind farm site to another must be treated with caution. Currently, no significantly new data can be drawn and transferred from studies on comparable activities.

The sound measurements of operational sound emissions indicate that there will be practically no acoustic overlap between adjacent wind farms. Moreover, it is assumed that the impact range of operational noise emissions on marine mammals is relatively small. However, the fact that the available data have been collected on small and medium-size wind turbines must also be considered. Any transfer of the resulting assessment on the potential impact of large-scale turbines must be treated with caution, and may even be inadequate.

No data exist so far on the potential impact of methods applied to investigate the bottom structure at construction sites. However, comparable studies indicate a potential threat to marine mammals, especially with regard to seismic studies.

The use of explosives to decommission the turbines would generate intense acoustic impulses that would be audible over great distances and would be very likely to cause severe injury or impairment to marine mammals at close range if done with no precautionary measures. No other available techniques can be assessed in this regard as yet, and must be studied in greater detail with regard to safety zones and potential mitigation measures. In addition, alternative methods should be developed and tested.

Measures for attenuating the wind turbine related sound emissions represent the best and most realistic strategy to reduce potential negative effects on the marine environment. The most comprehensive information is currently available on sound attenuation during the construction phase. Even though no detailed information has been published to date, an air-bubble curtain has been successfully used in a U.S.

study to reduce the emitted sound during pile driving activities. However, this technique, as well as alternative methods, must be tested for their effectiveness and applicability to the construction of wind turbines in the North and Baltic Seas.

## 2 Zusammenfassung

Die technischen und planerischen Vorbereitungen zur Errichtung von Offshore-Windenergieanlagen (WEA's) haben in den vergangenen Jahren auf nationaler und internationaler Ebene ihr Momentum beibehalten. Die geplanten Entwicklungen in der Deutschen Ausschließlichen Wirtschaftszone (AWZ) sind – bis auf wenige von der Genehmigungsbehörde abgewiesene Projekte – weitergeführt worden und auch international gibt es immer mehr Planungen für den Bau von Windparks im Offshorebereich sowie bereits erste Standorte mit existierenden Windparks. Aber auch die Untersuchungen der möglichen Auswirkungen der Offshore-WEA's auf den marinen Lebensraum und speziell auf marine Säugetiere sind intensiv weitergeführt worden. In der vorliegenden Literaturstudie werden die dazu vorliegenden Informationen zusammengeführt und diskutiert.

Ein Schwerpunkt dieser Studie liegt auf der akustischen Belastung der drei im Bereich der deutschen AWZ vorkommenden marinen Säugetiere (Schweinswale, Seehunde und Kegelrobben) durch Offshore-WEA's und umfasst sowohl die Schallemissionen im Zusammenhang mit dem Bau und Betrieb der WEA's und anderer damit verbundener Aktivitäten als auch Erkenntnisse zu den biologischen Auswirkungen auf die Tiere.

Aufgrund der Komplexität der Wirkungszusammenhänge und der bislang unzureichenden Datenlage erscheint eine Modellierung der möglichen Auswirkungen der Offshore-WEA's auf marine Säuger sinnvoll. Die nicht-akustischen Parameter, die in eine solche Modellierung einfließen müssen sowie die Struktur der Modellierung bilden einen weiteren Schwerpunkt dieser Studie.

Die Untersuchungen in Dänemark haben gezeigt, dass das Rammen der Fundamente der Anlagen offensichtlich großräumige Vermeidungsreaktionen der Schweinswale hervorruft und einen unmittelbaren negativen Effekt auf die Verbreitung der Tiere und ihre Habitatnutzung hat. Es bleibt jedoch unklar, durch welche Faktoren die dokumentierten Unterschiede in den dänischen Windparks zu erklären sind und wie lange die beobachteten Effekte anhalten werden. Dadurch ist die Übertragbarkeit der dänischen Ergebnisse – abgesehen von den unmittelbaren Auswirkungen der Rammaktivitäten – nur sehr eingeschränkt möglich. Eine Übertragung von Ergebnissen aus Studien zu vergleichbaren Aktivitäten ist ebenfalls nur begrenzt möglich und liefert derzeit keine signifikanten neuen Erkenntnisse.

Die Ergebnisse der Messungen von Schallemissionen der WEA's in der Betriebsphase deuten darauf hin, dass es praktisch keine akustische Überschneidung der durch einzelne Windparks beschallten Meeresbereiche geben wird. Darüber hinaus ist davon auszugehen, dass der Bereich um die einzelnen Anlagen herum, in dem es zu einer akustischen Beeinflussung der marinen Säuger kommen kann, sehr klein ist. Dabei ist jedoch zu berücksichtigen, dass die vorhandenen Erkenntnisse an kleinen und mittleren Anlagentypen gewonnen wurden und eine Übertragbarkeit auf die Auswirkungen der geplanten großen Offshore-WEA's nur eingeschränkt oder nicht möglich sein wird.

Bisher liegen keine belastbaren Informationen zur Beurteilung der möglichen Auswirkungen der zur Baugrunduntersuchung eingesetzten akustischen Verfahren vor.

Vergleichbare Untersuchungen deuten jedoch auf eine mögliche Gefährdung mariner Säugetiere vor allem durch seismische Untersuchungen hin.

Der Einsatz von Sprengstoff zum Rückbau der Anlagen würde zu sehr intensiven akustischen Impulsen führen, die über weite Distanzen wahrnehmbar sein würden. Diese Impulse würden mit hoher Wahrscheinlichkeit in der näheren Umgebung bei marinen Säugetieren zu schweren Verletzungen oder bleibenden Schäden führen, wenn keine Vorsichtsmaßnahmen getroffen würden. Andere Methoden zum Rückbau können bislang nicht beurteilt werden und müssen hinsichtlich der erforderlichen Sicherheitszonen und möglicher Minderungsmaßnahmen detailliert untersucht werden. Zusätzlich sollten weitere Methoden entwickelt und getestet werden.

Das vermutlich größte Potential zur Verminderung oder Vermeidung von Auswirkungen auf marine Säugetiere liegt in der Reduzierung der WEA-bedingten Schallemissionen. Die umfangreichsten Erkenntnisse liegen derzeit im Bereich der Möglichkeiten zur Schalldämmung während der Bauphase vor. Detaillierte Erkenntnisse sind zwar noch nicht veröffentlicht, aber im Rahmen einer in den USA durchgeführten Studie wurde die Schallminderung mittels Luftblasenschleier offensichtlich erfolgreich weiterentwickelt. Diese Technik sowie alternative Schallminderungs-Maßnahmen müssen jedoch zunächst noch weiter auf ihre Effizienz und Anwendbarkeit bei der Errichtung von Offshore-WEA's in der Nord- und Ostsee getestet werden.

### 3 Introduction

The German government has set the goal of doubling the percentage of energy produced by renewable sources from 2000 to 2010, thus reaching a level of 12.5%, and of further increasing this share of total German consumption to 20% by 2020. This proposed increase depends on the development of offshore wind farms; such projects have been planned in German waters since 1997. The development of these projects in Germany is encouraged through subsidies stipulated in §7 of the Renewable Resources Law (EEG). At the time of the preparation of this report, more than thirty proposals concerning possible sites for the installation of offshore wind turbines in the North and Baltic Seas were or had been reviewed by the Federal Maritime and Hydrographic Agency (BSH). To date, eight projects have already been commissioned, with up to eighty turbines per site during an initial phase of development, and construction activities should start in 2005. The ensuing phases of expansion to the final sizes of the wind farms will depend on the outcomes of the mandatory environmental impact studies to be conducted by the developers during the operational phases.

This trend towards the use of offshore wind energy can also be seen in other European countries, where some wind farm projects have already been realised and are in operation. While the existing offshore wind turbines have been installed in water of 1 to 18 m in depth, the sites planned in German waters are to be built in deeper waters of up to 40 m. In addition, the distance from shore will be greater for German projects, where several projects are planned at distances of approx. 100 km from shore, while the maximum distance to the mainland would be 300 km. The offshore wind farms built in other countries are within 20 km of the shore.

Despite the positive effect in reducing the CO<sub>2</sub> production and the resulting benefits for the environment, the construction of wind turbines in the offshore areas is also likely to have an impact on the marine environment. As a total of several thousands wind turbines may ultimately be installed in the North Sea alone, there is a great need for knowledge in order to permit assessment, avoidance or mitigation of negative effects on the marine environment. An indispensable part of the information needed is that on the abundance and distribution of species in the areas of interest and their sensitivity to emission or activities related to wind turbines.

A previous comprehensive report to the UBA (KNUST *et al.* 2003) revealed a number of topics that have been recognised as points of departures for further research efforts. They constitute the foundation for the objectives of the present report, which is designed to provide an update on the progress achieved concerning these topics.

The main focus of this report is on the potential impacts upon marine mammals by the construction and operation of the wind turbines which would be greater than those affecting other marine biota. Marine mammals have a highly developed sense of hearing and depend strongly on this sense. At the same time, there are numerous activities associated with the life-cycle of a wind turbine which involve more or less intense sound emissions. The potential effects on marine mammals may range from subtle reactions to permanent habitat loss and physical damage. These effects may have an impact both on individuals and on the marine mammal populations as a whole. Even though in many respects, the type of effect can be identified, it is still impossible to quantify the temporal and spatial extent of the zones of influence.

## 4 Objectives of the Present Report

This report represents a review of the international literature, considering published articles in peer-reviewed journals as well as reports, online-documents, agendas and conference proceedings and shall provide an overview over the latest gain in knowledge about the influence of offshore wind farms on marine mammals. The topics that were searched includes the basic elements that are necessary to assess the impact of offshore wind farms on marine mammals, as there are (i) the biology of species of concern, (ii) the abundance of species of concern, (iii) the acoustic aspects of interference of offshore wind farms with marine mammals, (iv) useful mitigation measures. Based on formerly expressed research need concerning marine mammals (KNUST *et al.* 2003) special attention has been given to the following points.

- ◆ habitat use and home range of marine mammals
- ◆ audiograms of marine mammals
- ◆ determine influence of noise on marine mammal hearing abilities (TTS)
- ◆ pile driving during construction of offshore wind turbines (e.g. ramming)
- ◆ sound emissions of operational offshore wind turbines (different turbines and foundations).

As the potential impact of acoustic emissions on marine mammals is a complex issue in general and the relevant knowledge is insufficient or non-existing in many respects, a useful way to proceed is to build theoretical models for the effects. As a first step, a compilation of the non-acoustical parameters which are necessary to know for such a model is included in this report. Based on these parameters it should be possible to model the effects of offshore wind turbines in the absence of quantitative data on their acoustic effects.

## 5 Marine Mammals in German Waters

### 5.1 Cetaceans

In German territorial waters and the Exclusive Economic Zone (EEZ), several species of cetaceans can be observed occasionally; however, nearly all of them can be considered non-indigenous to the areas under consideration. These species includes the toothed whales white-beaked dolphin (*Lagenorhynchus albirostris*) (KINZE *et al.* 1996), white-sided dolphin (*Lagenorhynchus acutus*), bottlenose dolphin (*Tursiops truncatus*), common dolphin (*Delphinus delphis*), Risso's dolphin (*Grampus griseus*), long-finned pilot whale (*Globicephala melas*), Orca (*Orcinus orca*) (all latter cf. [http://www.cms.int/reports/small\\_cetaceans/contents.htm](http://www.cms.int/reports/small_cetaceans/contents.htm)), northern bottlenose whale (*Hyperoodon ampullatus*) (LICK & PIATKOWSKI 1998), and sperm whale (*Physeter macrocephalus*) (cf. LUCKE 2000), as well as the Minke whale (*Balaenoptera acutorostrata*) as the only representative of baleen whales (cf. LUCKE 2000).

Only the harbour porpoise (*Phocoena phocoena*) can be found regularly and also breeds in German waters (HAMMOND *et al.* 2002). This indigenous species is briefly described in the following.

### 5.1.1 Harbour Porpoises (*Phocoena phocoena*)

Order: *Cetacea* (Whales)

Suborder: *Odontoceti* (Toothed whales)

Being a shallow diving, small cetacean (up to 1.6 m, 73 kg) (BENKE *et al.* 1998) the harbour porpoise inhabits the coastal areas of the northern hemisphere, including the North and Baltic Seas. Its longevity is about eighteen years, and it reaches sexual maturity at the age of four (females) (BENKE *et al.* 1998) and at a body length of 149 cm (ADDINK & SMEENK 1999 in BOOIJ 2004).

The mating season for harbour porpoises in German waters is assumed to be June to August (BENKE *et al.* 1998). Most adult females reproduce annually, giving birth to a single calf between May and July. Both mating and reproduction periods can differ regionally (EVANS 1998). The calves are nursed for eight to ten months, and as mating takes place between June and August, most adult females are both pregnant and lactating at the same time, resulting in a high energetic need during this period (REEVES *et al.* 2002).

#### *Prey/Diet:*

Harbour porpoises are opportunistic feeders with a broad prey spectrum: the stomach contents of stranded animals examined by BENKE *et al.* (1998) included thirteen fish species. The spectra differed between whales from the North Sea and from the Baltic Seas. While in the North Sea, the common sole and the sandeel combined making up more than half of the ingested mass, the most important prey item of Baltic harbour porpoise seemed to be the goby (BENKE *et al.* 1998, KOSCHINSKI 2002). It is proposed that harbour porpoises require constant feeding throughout their lives, i.e. they do not fast for any extended periods (BJØRGE 2003).

## 5.2 Pinnipeds

In German territorial waters, and the EEZ, two species of pinnipeds may be regarded as indigenous. Systematically, they belong to the same superfamily:

Order: *Carnivora* (Carnivores)

Suborder: *Pinnipedia* (Pinnipeds)

Superfamily: *Phocoida* (Seals)

The two species under consideration are described briefly in the following.

### 5.2.1 Harbour Seals (*Phoca vitulina*)

The harbour seal (body length approx. 1.75 m, mass approx. 80-100 kg, REIJNDERS 1992) has a large distribution throughout the Atlantic and Pacific coasts of the northern hemisphere (THOMPSON *et al.* 1998). It can be found in the German waters of the North Sea, but vanished from the German coasts of the Baltic Sea during the first half of the 20<sup>th</sup> century due to over-exploitation (hunting). Today a line from the island of Rügen northwards is the eastern boundary of the distribution of the harbour seal in the Baltic Sea. The south-eastern-most haul-out site of harbour seals in this region is reported at

Rødsand, Denmark. Above that, an isolated population can be found at Gotland, Sweden. This species is non-migratory, but besides its littoral distribution it may ascend into rivers for many kilometres (BIGG 1981). The determination of densities by the airborne line-transect method revealed a preference for coastal areas (HERR 2004).

Despite water being the main element of the harbour seal, it shows year-round use of other habitats, such as sand banks in the tidal area and beaches (<http://www.waddensea-secretariat.org/tgc/MD-Stade.html>), where the animals congregate in groups of mixed age and sex (VAN HAAFTEN 1981). While the aquatic habitat supports feeding, courtship and mating activities for seals, the haul-out places are essential for such other vital biological functions as whelping, nursing, moulting and resting (BIGG 1981).

Harbour seals reproduce annually, and the birth season lasts one to two months (BIGG 1981), in the German Wadden Sea typically from May to July. The offspring is nursed for four to six weeks. The pups shed their white first fur (lanugo) prior to birth, i.e. they are born in their spotted adult coat, and are able to swim only minutes after birth. They are, however, nursed on land and are sensitive to disturbance during that time.

Annual moulting takes place during July and August, representing another period of obligatory use of the haul-out sites.

#### *Prey:*

Harbour seals are opportunistic feeders that mainly prey on different flatfish species and other slow moving demersal fish. They find their prey primarily with the help of their vibrissae that are used to detect either the fish or turbulences in the water caused by the movements of the fish (DENHARDT *et al.* 1998, 2001).

### **5.2.2 Grey Seals (*Halichoerus grypus*)**

The grey seal is a larger seal species, with males growing to a size of up to 2.3 m and weighing up to 300 kg, and females reaching 1.9 m in length and a body mass of 150 kg.

The general demands of the grey seal concerning aquatic and haul-out habitat are similar to those described for the harbour seal; however, in addition to sand banks and beaches, the grey seal also uses dunes and salt marshes (<http://www.waddensea-secretariat.org/tgc/MD-Stade.html>). This species occurs throughout the temperate waters of the North Atlantic. Based on genetic studies it has been suggested that there are three different populations (THOMPSON *et al.* 1998): in the western North Atlantic, the eastern North Atlantic and the Baltic Sea. These populations are likely to have no genetic interchange. Within the German EEZ, grey seals are found at haul-out sites on Helgoland and the Knob sandbanks, which form the south-eastern-most colonies of their population.

About one month before the birth of the pups, the adult males and females congregate at the beaches, with the males displaying territorial behaviour. Pups are born in the winter (November and December in the Wadden Sea) with white, long-haired fur (lanugo). Even more than the harbour seal pups, the young grey seals depend greatly on undisturbed, non-flooded haul-out sites. Despite their general ability to swim, they avoid the water because when immersed, their lanugo gets soaked and thus loses its insulating function. The lanugo is shed after two to three weeks, when the growing blubber layer sufficiently shields the cold, and is replaced by the short-haired fur



comparable to that of the adults. At about the same time (approx. 20 days after birth) nursing ceases. The male grey seals moult around the beginning of February, while the females renew their fur in March.

*Prey/Diet:*

Grey seals feed mainly on fish (cod, sandeel, salmon or flatfish) and only occasionally prey on crustaceans and bivalves.

## 6 Bioacoustics of Marine Mammals – Progress in Knowledge

The coastal waters inhabited by the species described above have seasonally fluctuating, but overall poor visibility. Especially in such murky waters, the acoustic senses of marine mammals are of great importance for: (a) communication within social groups or between potential mating partners; (b) finding and catching prey; (c) avoiding such threats as predators, dominant conspecifics, nets or boats; and (d) orientation. Both bioacoustic aspects, producing and receiving sounds, are important; therefore latest findings on vocalisation and hearing ability are reviewed below.

### 6.1 Vocalisations of Marine Mammals

All thirty-three species of pinnipeds throughout the world share the behavioural characteristic of using a complex and highly vocal form of communication. All pinnipeds are able to produce sounds both in air and underwater; however, depending on the species, the vocalisation may be focused on either of these elements (SCHUSTERMAN & VAN PARIJS 2003).

In contrast to e.g. sea lions, harbour seals appears to vocalise rather occasionally when hauled out. Audible sounds produced in air involve the bleats of pups and guttural threats of adults (SCHUSTERMAN & VAN PARIJS 2003). In the past, seals were thought to only rarely produce sounds under water, but recent studies found them to use a great repertoire of vocalisations when submerged (ROGERS 2003, SCHUSTERMAN & VAN PARIJS 2003, STIRLING & THOMAS 2003). Moreover, the recordings made by BJØRGSÆTTER & UGLAND (2004) revealed differences in the frequency contour of male harbour seal vocalisations as well as geographical variations in the use of different sound types. Also, evidence was found that the frequent calls of harbour seal pups, that can be detected by the adults at ranges of up to 1 km in air (TERHUNE 1991), are individually distinctive and therefore may play an important role in maintaining contact between mother and offspring (KHAN 2004). Analysis of calls of fifteen captive harbour seal pups revealed frequency ranges between 103 and 8596 Hz (mean range 237 to 1225 Hz). The mean frequency at peak amplitude was 805 Hz (range 181 to 3106 Hz) (KHAN 2004).

Adult grey seals, juveniles and pups were found to produce distinct tonal and guttural sounds in air during breeding and lactation and underwater (ASSELIN *et al.* 1993, MCCULLOCH 1999, cited in SHAPIRO *et al.* 2004). Furthermore clicks and hiss sounds were recorded from grey seals (SCHEVILL *et al.* 1963, OLIVER 1978). The calls of grey seal pups appear to be stereotyped and individually distinctive (CAUDRON *et al.* 1998, MCCULLOCH 1999 cited in SHAPIRO *et al.* 2004)

Like many other toothed whales, the harbour porpoise is proven to use echolocation (BUSNEL *et al.* 1965, MØHL & ANDERSEN 1973, KAMMINGA & WIERSMA 1981, AKAMATSU *et al.* 1994). This enables it to obtain considerable information about its environment for a number of different purposes (e.g. detection of food, obstacle and predator avoidance, navigation). These echolocation signals (“clicks”) are short, pulsed signals and consist of at least two acoustic components: a high frequency component which in adult animals attains its highest intensity at 130 kHz, and a low frequency signal component of 1.4 – 2.5 kHz (VERBOOM & KASTELEIN 1995) at a source sound level of 100 dB re 1 µPa at 1 m (SCHEVILL *et al.* 1969). The latter is supposed to code some information with regard to communication (VERBOOM & KASTELEIN 1995). However, so far there is no definite confirmation on the use of these signal components for communicational purposes by the harbour porpoise.

RICHARDSON *et al.* (1995) and WARTZOK & KETTEN (1999) give a comprehensive overview of information on the active use of sound by toothed whales. Equivalent information with focus on harbour porpoise can be found at KNUST *et al.* (2003).

## 6.2 Hearing in Marine Mammals

### 6.2.1 General Effects of Underwater Noise on Marine Mammals

Marine mammals, as the three species under consideration in this report, use sound to communicate and navigate in an environment characterised by highly variable level of natural background noise and, over the past decades, by a growing level of man-made sound. There is an increasing awareness of the importance of sound to marine mammals. Any man-made noise can potentially have an effect on a marine mammal, but the assessment of that impact is, especially for the harbour porpoise, notoriously difficult. They are often extremely cryptic, remain submerged for long times, never venture onto land (except for strandings) and may wander extensive distances through the world’s oceans (GASKIN 1984).

Most noise generated by offshore oil operations is low frequency, mostly <1kHz, although higher frequency sounds are also generated. Especially seals are known to be sensitive to those frequencies, while small (toothed) cetaceans are less sensitive to low frequencies. There are no direct measurements of either the frequency range or sensitivities of hearing in large whales, but circumstantial evidence suggests that they may have good low frequency hearing. Seismic surveys have been shown to cause avoidance behaviour in the two seal species present in the North Sea, and in a range of large cetacean species. It is likely that seismic survey work will affect foraging behaviour by any seals and large whales in the sea areas. Current mitigation methods are probably generally effective in preventing physical damage.

The effects of sound immissions can range from mild irritation through impairment of foraging or disruption of social interactions to hearing loss and, in extreme cases, may lead to injury or even death. As pressure-sensitive organs, the ears of marine mammals are among the tissues that suffer the greatest damage from the pressure of a loud sound (KETTEN 2000). Partial loss of hearing abilities occur e.g. due to rupture of the tympanic membrane and leakage of blood into the middle ear, or when the hair cells that mediate the sound information to the auditory nerves are damaged. The latter may be caused by either a very loud event, prolonged exposure to a loud sound, or chronic exposure to noise (cf. CONTINENTAL SHELF ASSOCIATES 2004).

### 6.2.2 Anatomy of the Ear

Pinnipeds, with their semi aquatic life history, and cetaceans, leading a holo-aquatic life, are adapted to different degrees to hearing underwater sounds.

The most pronounced differences in hearing mechanisms between marine and terrestrial animals can be found in cetaceans. All species of cetaceans lack the outer ear flaps (or pinnae) and, moreover, in odontocetes (toothed whales) the ear canal is very narrow and non-functional. The middle and inner ear is encapsulated into a bony structure, which itself is suspended by ligaments and therefore acoustically separated from the bones of the skull. The conduction of sound to the middle and inner ear is provided by the lower jaw, which is filled with a fat capable of sound transmission as well as fat bodies lateral to the inner ear bones. Toothed whales have more nerve cells associated with hearing than terrestrial mammals. A thick and stiffened basilar membrane promotes high frequency hearing ability in odontocetes, as opposed to the exceptionally low frequency hearing of baleen whales (see NEDWELL *et al.* 2004 for review). In general, cetaceans are hearing specialists which use sound for orientation, to explore and communicate. They have a wider hearing range and are more sensitive to sound than other species.

Pinnipeds are less specialised in aquatic hearing, as they alternate between hearing in air and under water and because they additionally rely on their visual and tactile senses. However, pinnipeds have either reduced or no external ear flaps, and the ear canal is surrounded by muscles that close the ear canal to water during diving. Unlike in cetaceans, the pinniped ear is still attached to the bone structures of the skull.

### 6.2.3 Hearing Thresholds and Audiograms

While models exist for predicting hearing abilities of terrestrial mammals from information about the anatomy of the ear (FAY 1988), the only way to get information about the hearing abilities of marine mammals is to conduct direct measurements, e.g. to obtain audiograms by determining hearing thresholds at distinct frequencies.

Audiograms can be obtained by either of two principal methods: behaviourally, where a trained animal has to react in a predefined manner if it has heard the signal, or by measuring the Auditory Evoked Potentials (AEP –respectively Auditory Brainstem Response, ABR) when the neuronal (i.e. electrical) impulse in the auditory nerves of the animal are measured. The experiments can be conducted either in air or in water; therefore the resulting data refers to one of these two possible media.

A recent review of the available information on marine mammal audiograms by NEDWELL *et al.* (2004) includes, in addition to the data quoted in previous reports (e.g. KNUST *et al.* 2003), audiometric data on grey seals (see Fig. 1).

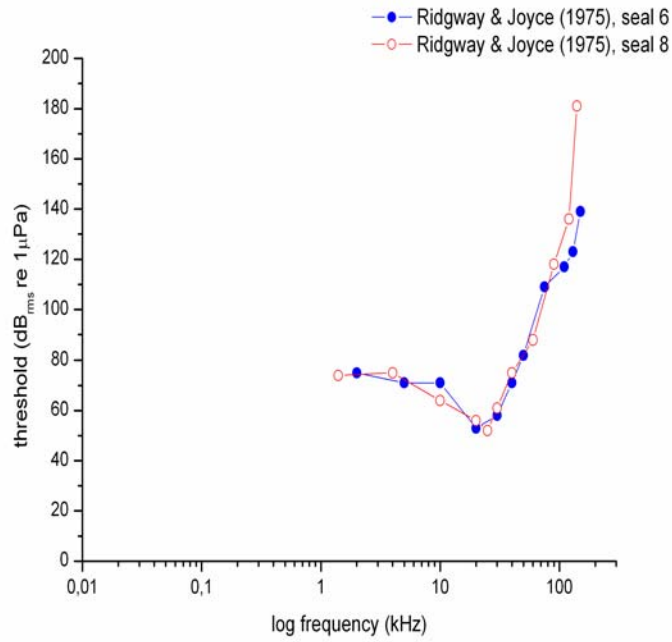

Fig. 1: Absolute hearing thresholds of two grey seals (*Halichoerus grypus*) in water, obtained by AEP technology (from RIDGWAY & JOYCE 1975).

Data on the hearing abilities of a harbour seal and a harbour porpoise have also been published in several studies over the last three decades (see Figs. 2 & 3).

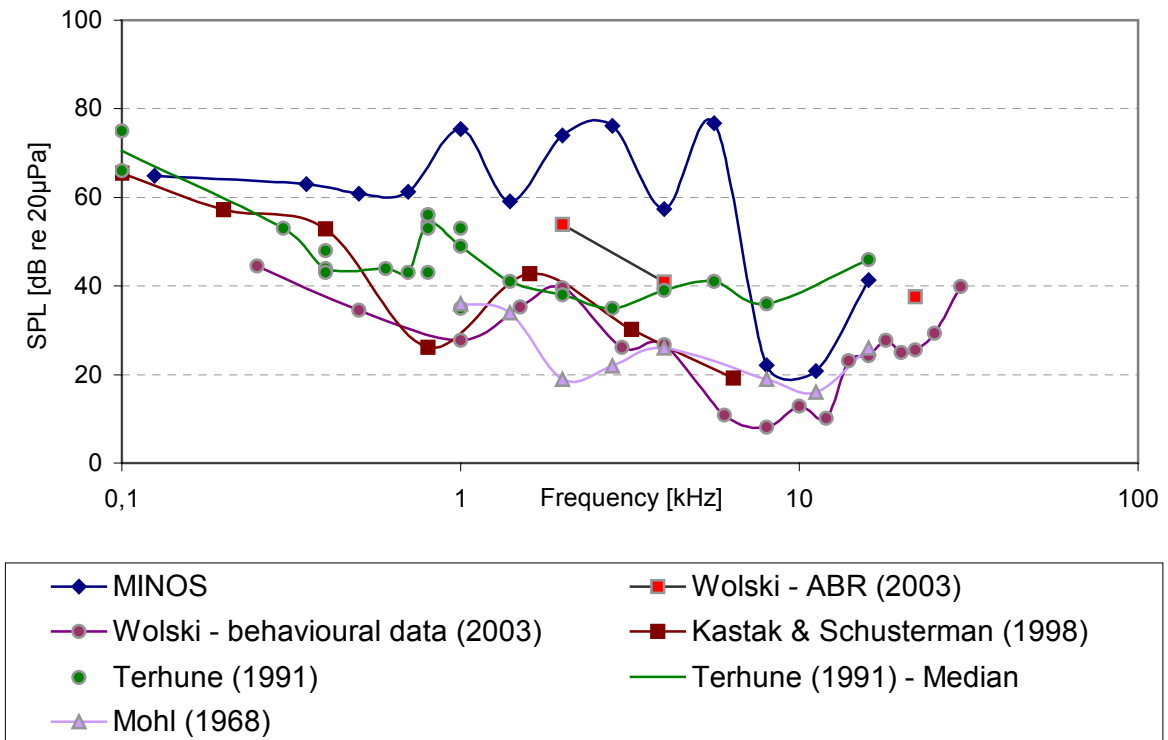

Fig. 2: Absolute hearing thresholds of harbour seals (*Phoca vitulina*) in air achieved in different studies by using behavioural and electrophysiological methods (AEP) (MINOS: Lucke *et al.* 2004).

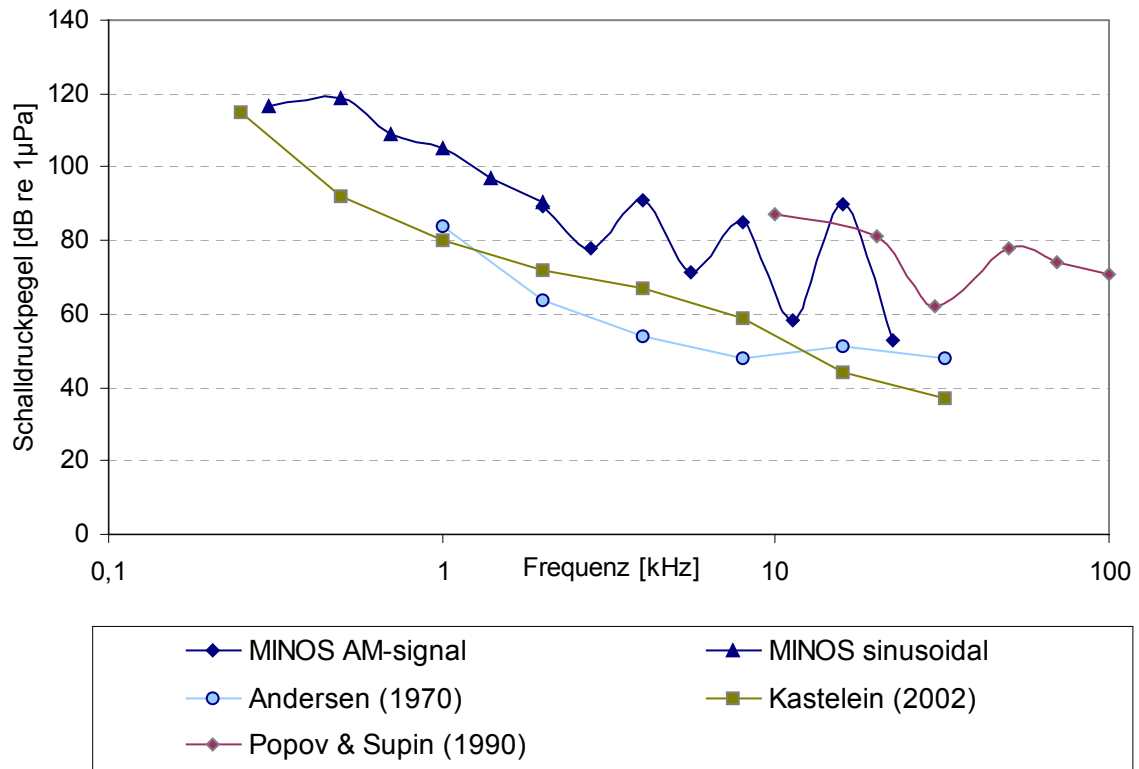

Fig. 3: Absolute hearing thresholds of harbour porpoises (*Phocoena phocoena*) achieved in different studies using behavioural and physiological methods (AEP) (MINOS: Lucke *et al.* 2004).

In recent years, great progress has been made in obtaining audiograms from various species of marine mammals. Nevertheless, the constraints of the knowledge on population levels must not be disregarded. There is evidence that the hearing abilities in bottlenose dolphins (*Tursiops truncatus*) may vary with both sex and age (RIDGWAY & CARDER 1997). It is therefore recommended that the range of normal auditory capabilities based on data from many individuals be determined, which, however, is usually difficult when working with marine mammals. The quality of the underlying data, such as audiograms and hearing thresholds, is crucial for the overall quality of any statement about the effects of noise on marine mammals.

#### 6.2.4 Masking

Studying auditory masking (i.e. impaired reception of an acoustic signal caused by background noise) in one captive harbour seal and two other captive pinnipeds, SOUTHALL *et al.* (2003) confirmed that these animals are hearing generalists with respect to frequency processing. In aerial hearing experiments, the critical ratio (CR) between the masked hearing threshold and the masking noise increased monotonically with frequency. A noticeable low CR at a defined frequency, which would indicate a more efficient extraction of signals from the masking background noise at this particular frequency, was neither found in this (SOUTHALL *et al.* 2003) nor in a previous in-water study conducted on the same authors (SOUTHALL *et al.* 2000). In summary, while the tested pinnipeds lack specialisation for detecting specific frequencies over masking noise, they generally perceive signals at a relatively low signal-to-noise ratio in both air and water, enabling them to hear e.g. communication calls of conspecifics in a typically

noisy marine environment. The presented results of these studies will be helpful in estimating communication ranges under anthropogenic noise conditions, and the effects of anthropogenic noise.

The ability of harbour seals to localise broadband sound signals (as) is relatively low under water as compared to other phocid species (TERHUNE 1974), whereas in air, they show a better ability to localise such sounds as e.g. a call of conspecifics than other species tested (HOLT *et al.* 2004).

Comparable data are not available for the harbour porpoises yet.

### **6.3 Sound Induced Temporary Threshold Shift (TTS) in Marine Mammals and Definition of Marine Mammal Safety Zones (MMSZ)**

In recent years, several TTS studies on marine mammals (whales and seals) have been conducted and the results obtained form the basis of threshold values used to define safety zones around sites where high levels of underwater sounds are produced (e.g. pile driving or explosions). TTS studies are conducted as behavioural experiments aiming at the investigation of the effect of sound exposure on the hearing abilities of the individual studied.

The experiment includes the following steps: (i) the hearing threshold of the animal is measured, (ii) the animal is exposed to a defined acoustic signal, (iii) the hearing ability is tested again and compared to the initial hearing performance. The sound pressure level of the signal is increased and steps (ii) and (iii) are repeated until the comparison with the initial hearing threshold reveals a (temporary) shift in perception performance. The experiment is designed so as to avoid permanent physical damage to the animal.

A review of TTS studies in marine mammals published in the years before 2002 has been provided by KNUST *et al.* 2003. Meanwhile, further TTS-studies have been conducted on a bottlenose dolphin with respect to exposure to continuous sound (NACHTIGALL *et al.* 2003, 2004). These studies, using two different techniques (behavioural vs. electrophysiological), revealed that exposure to a continuous sound level of up 179 dB re 1 $\mu$ Pa ranging from 4 to 11 kHz for up to 55 min was sufficient to cause a TTS of 11 dB on average (NACHTIGALL *et al.* 2003). This maximum TTS effect occurred 5 min after exposure, and recovery was rapid, with 1.5 dB per doubling of time (NACHTIGALL *et al.* 2004).

Even though the available data are still insufficient for a final definition of thresholds and the conclusions are still controversial (e.g. <http://www.nrdc.org/wildlife/marine/cjrmj0501.asp>) the National Marine Fisheries Service (NMFS, now NOAA Fisheries) as the regulatory agency in the U.S. adopted received sound pressure levels ("exposure levels") of 180 dB re 1 $\mu$ Pa for whales and 190 dB re 1  $\mu$ Pa for seals as the maximum values to which animals may be exposed. For whatever activity and associated sound level the permit has been issued, it is mandatory to avoid exposure of a marine mammal to sounds of higher intensity than these thresholds, thereby creating a Marine Mammal Safety Zone (MMSZ). As the source levels of the sounds may differ for the different activities, these threshold values are reached at different distances from the source. Within this range, the whole area must be surveyed for the presence of marine mammals by means of all available measures to detect such an animal.

During the ramming activities for construction of the San Francisco-Oakland Bay Bridge (SFOBB, CALTRANS 2001) a Marine Mammal Safety Zone (MMSZ) of 100 m in all directions of the pile-driving site was established. A bubble curtain was in place and

hammers of two different sizes were used (Menck 500 kJ and Menck 1700 kJ). When the bubble curtain was turned off for fish and hydroacoustic monitoring (10. Sept 2004, twice; 24. Jan 2004, for 10 strikes), the MMSZ was extended to 350 m around the pile-driving site. The MMSZs were based on hydroacoustic data that had been collected during previous pile driving (RMS sound pressure level below 190 dB was used to define the MMSZ, see also REYFF 2003). Before hydroacoustic data were available, the MMSZ was set at 500 m.

When marine mammals were sighted within the MMSZ prior to the start of a pile driving session, the beginning of the ramming action was delayed until there was no further sighting for 15 min. Already commenced pile driving was not stopped when a marine mammal entered the MMSZ during ramming activities. Based on the noise measurements during the Pile Installation Demonstration Project (PIDP) conducted prior to the SFOBB construction, the radius of the MMSZ has been reduced from the initial size of 500 m to 100 and 350 m (with and without bubble curtain, respectively), thus meeting the 190 dB standard of the NMFS. However, as stated in the report by CALTRANS (2001) one California sea lion was obviously behaviourally affected by the pile driving noise at a distance of approx. 1000 m from the sound source, despite the use of a bubble curtain (see Chapter 10.1). The authors concluded that the sound at this distance still reaches a level that could startle some sea lions.

#### **6.4 Sound Levels in Perception Units: dB<sub>ht</sub> (Species)**

Rather than expressing sound pressure levels in dB re 1 $\mu$ Pa, NEDWELL *et al.* (1999, 2001, 2003) propose the use of a new scale of sound which is comparable to the weighted dB(A) scale used in human audiometry. The dB<sub>ht</sub> scale, as suggested by Nedwell *et al.*, is species specific and is estimated by passing a given sound through a filter that mimics the hearing ability of the species. It would reflect the different sensitivity of the animal's ear at different frequencies. This approach lacks the most fundamental information for usefulness, as for most species of concern, only one or a few animals have been tested for hearing sensitivity. Therefore, its premature use could indicate a precision and a declarative strength that does not in fact exist as yet. However, as soon as sufficient data is published, this approach may provide a useful tool, as its concept of a weighted scale is already familiar to a broad public.

## 7 Measurement of Background Noise Levels and Propagation Loss

The marine environment has never been a silent world. Several natural sources, including the wind, waves, earthquakes, currents and turbulence, thunder and lightning strikes, precipitation, sea-ice and, last but not least, marine life itself, are known to contribute to the ocean background noise (HILL 1985, HILDEBRAND 2004). From this list, it is obvious that the natural background noise is subject to change, due mainly to changing weather conditions. Data on natural background noise must either therefore be given as a long-term mean, or be measured at an appropriate time resolution, parallel to the measurements of noise impact under consideration.

The frequency of ambient noise ranges between 1 Hz and 100 kHz (VERBOOM 1991 in BOOIJ 2004). Under natural conditions, the reception of man-made noise by marine mammals is always accompanied by background noise. Therefore, one important parameter when estimating the impact of anthropogenic sound is the distance from the sound source at which the noise level drops below the background level. This distance of detectability is subject to change along with the variations in the background noise level (RICHARDSON *et al.* 1995), as well as the transmission loss, which usually ranges between  $10 \log r$  [ $r$  = distance in m] in shallow water conditions and  $20 \log r$  in deep water. The North and Baltic Seas are acoustically shallow waters with a characteristic of sound propagation that lies between spherical wave spreading and cylindrical wave spreading. Measurements from different distances taken during pile driving indicate a decrease in sound level of 4.5 dB per distance doubling (BETKE *et al.* 2004 and DEWI 2004). This value is in good accordance with an equation describing the transmission loss in the North Sea (sand bottom, winter time only, depth up to 100m, distance 1 m – 80 km, frequency range between 100 Hz and 10 kHz) provided by Dr. Thiele, FWG, Kiel (in KNUST *et al.* 2003):

$$TL = (16.07 + 0.185 F)(\log(r) + 3) + (0.174 + 0.046 F + 0.005 F^2) r$$

[where  $F = 10 \log(f/\text{Hz})$  and  $r$  = distance in km]

The low-frequency components of sound can propagate over long distances (up to hundreds of kilometres), while higher frequencies are attenuated in shorter distances.

The offshore wind farms built to date are in fairly shallow water, while the proposed German turbines are to be installed in deeper waters. It should be noted that water depth has an influence on sound propagation and that noise may propagate further in deeper waters (cf. statement in NEDWELL *et al.* 2003b, NEDWELL *et al.* 2001).

In order to assess the potential impact of offshore wind turbines on the marine environment it is in general indispensable to measure the background noise condition before, during and after installation of the wind turbines. Due to the temporal and spatial variability of the acoustic conditions it is also necessary to conduct such measurements at every wind farm site separately and repeatedly under different weather conditions and preferably at different distances. A methodological description is given in DEWI (2004). However, from a biological point of view the recommended frequency band for the measurements should be altered as sound recordings during the installation of wind turbines at Horns Rev, Denmark, revealed that the spectrum contains components of up to 100 kHz. Thus, the full spectrum of the emissions overlaps with the functional range of acoustic sensitivity of both the harbour porpoise and the two seal species. In order to



gain statistically reliable data for an environmental impact assessment, the frequency range of wind turbine related sound measurements should be expanded to 100 kHz.

It is important to note that the effect of single turbines, wind farms and even multiple wind farms on marine mammals must be assessed in correlation with the already existing noise regime; i.e., total sound exposure must be measured. As this changes over time, models should be designed to predict the total sound exposure at a given site. This requires a map of “normal” background noise conditions, data on the effect of changing weather conditions and on stratification in the water column, and recordings of emissions from various anthropogenic sound sources at sea. Such a sound map would be useful for any country planning to build offshore wind turbines.

## **8 Site Investigation for Offshore Wind Farm Construction: Noise Emitted and Effects on Marine Mammals**

Prior to approval by the BSH, the authorising authority for wind farms within the German EEZ, several investigations are required to specify the quality of the sea floor (ATZLER *et al.* 2003). This methodology includes the use of echo sounder (mapping of bathymetry), side scan sonar (to specify sediment types), boomer (bottom-penetrating air gun technology) as well as core drilling (verifying results from seismic tests). The sound emissions from such activities have been described in some reports related to military activities, oil and gas exploration, and site investigations for such offshore structures as pipelines and oil and gas platforms.

To date no studies have been published concerning the site investigation procedures for the construction of an offshore wind farm and its potential effects on the marine environment. Due to this lack of data, emphasis has been placed on available data for studies focusing on the effect of the use of these techniques in relation to the three target marine mammal species.

### **8.1 Airgun/Seismic Studies**

The goal of a seismic study, whether for site investigation for an offshore wind farm or for oil and gas exploitation, is to obtain an image of the different strata present in the sea floor structure. For this purpose, strong sound impulses are emitted under water by airguns (often in an array) towed behind a ship. The airguns release air at high pressure into the water which creates a sound pressure wave due to the expansion and contraction of the bubble (HILDEBRAND 2004). For maximum sound signal intensities, the single airguns of the array (for oil industry application, typically twelve to forty-eight guns) are timed to fire synchronously, thus producing a coherent pulse. The pressure output of an airgun array is proportional to (1) its operating pressure, (2) the number of airguns, and (3) the cube root of the total gun volume (HILDEBRAND 2004). By using an array of airguns, the operators try to direct the sound towards the seafloor, with the returning signal delivering the desired information on bottom structures. However, as low frequency sound in principle spreads out omnidirectionally from a sound source, part of the impulse also travels sideways through the water. On its propagation path, it is subject to reflection and refraction, leading to a complex sound signal at some distance from the airgun array. Prediction of this distant sound wave is extremely difficult (NEDWELL *et al.* 1999). The source levels (at 1 m) are as high as e.g. 256 dB re 1

$\mu\text{Pa}$  RMS output pressure, with the peak pressures in the range between 5 and 300 Hz (see review in HILDEBRAND 2004). GOULD & FISH (1998) have recorded seismic signals up to a frequency of 22 kHz. They detected considerable acoustic energy even at these higher frequencies at greater distances from the seismic source.

### THOMPSON 1998

The BROMMAD study (THOMPSON 1998) was conducted to investigate the response of harbour porpoises, harbour seals and grey seals on seismic survey sounds. Experimental airgun surveys were undertaken using real airguns fired at intervals of 10 sec, to produce sounds with the correct spectral characteristic. However, the size of the airguns or overall arrays was rather small, so as to minimise the risk for the study animals and other marine mammals in the area of the study site (Table 1). The signal strength emitted in an actual commercial survey is much larger, up to 80,000  $\text{cm}^3$  (the size of the pressure chamber of airguns in  $\text{cm}^3$ ) than in the BROMMAD study, and may be produced over longer periods.

Table 1: Specification of tests conducted in the course of the BROMMAD study (after: THOMPSON 1998).

<i>Species</i>	<i>Location</i>	<i>Airgun</i>	<i>Estimated source level</i>
Harbour seal	Scotland	160 – 1920 $\text{cm}^3$	215 – 224 dB re 1 $\mu\text{Pa}$ at 1 m
Grey seal	Baltic	160 – 1920 $\text{cm}^3$	215 – 224 dB re 1 $\mu\text{Pa}$ at 1 m
Harbour porpoise	Orkney Islands	3 x 649 $\text{cm}^3$ array	Not specified in report

Four free-ranging harbour seals were observed via telemetry during eight trials of experimental surveys, three of which showed reactions to the emitted sounds. The reactions included (i) an initial startle response detected in heart rate, followed by a longer decrease of heart rate, (ii) rapid swimming behaviour away from the sound source until the end of the stimulus, (iii) prolonged surface periods, and (iv) haul-out behaviour. The seals that were still in the water after the firing of the test array stopped returned to normal behaviour within minutes.

The same experiment was conducted with five grey seals, which all showed avoidance behaviour to the sound of the seismic test. The reactions were changes in diving behaviour (no foraging dives during sound exposure) and fast swimming away from the test site. Three of the observed animals, which did not haul out during the experiment, but remained in the water, returned to normal behaviour on average within two hours (range 0 to 11.5 hrs,  $n = 10$ ) after seismic noise emission ceased.

Both seal species were found to frequent the areas of the test site after the investigation period, even if the sound exposure experiment was conducted on several consecutive days. The animals were found to react to sound levels 50 to 60 dB below the assumed threshold of physical damage or pain, encouraging the concept of soft-start procedures (cf. Chapter 14.2) to avoid such physical effects.

Free-ranging harbour porpoises were detected by using hydrophones lowered from a ship following a predetermined transect line off the Orkney Islands. Comparison of detection rate and observed behaviour before and during the active seismic experiment did not show any significant difference. Harbour porpoises were observed as close as

400 m from the active airgun array. The sound immission for these animals was estimated to be 176 dB re 1  $\mu$ Pa at this distance from the source.

An investigation conducted during a commercial seismic study off Shetland, deploying a 64,272 cm<sup>3</sup> airgun array, revealed no significant detection rates of harbour porpoises when comparing full power activity, soft-start procedure and periods of silence. However, the detection of the animals took place using a hydrophone from a ship that was at least one mile ahead of the gun array. Effects at a closer range would have therefore remained unresolved in this study set-up.

In conclusion, the authors state that due to their high-frequency hearing sensitivity, harbour porpoises appear to be less sensitive to seismic sounds from airguns than harbour seals and grey seals, which are assumed to have reacted to the higher share of generally low frequencies from the air-guns, i.e. those above 100 Hz.

### **STONE 2003:**

Surveys conducted between 1997 and 2000 on observations of marine mammals during seismic activities in near UK waters are reviewed and statistically analysed in the report by STONE (2003). During 201 surveys, a total of 28,165 individual marine mammals were sighted, and a wide spectrum of species considered, including only a few observations of harbour porpoises, harbour seals and grey seals (111, 6 and 16 individuals, respectively). Seal sightings were not analysed further in the review. For some statistical analyses, the species were grouped together as e.g. "small odontocetes", including Risso's dolphin (*Grampus griseus*), bottlenose dolphin (*Tursiops truncatus*), common dolphin (*Delphinus delphis*), striped dolphin (*Stenella coeruleoalba*), white-beaked dolphin (*Lagenorhynchus albirostris*), white-sided dolphin (*Lagenorhynchus acutus*) and harbour porpoise.

Combining all sightings of small odontocetes, the sighting rates were found to be significantly lower during active seismic surveys than during periods of silence. All the small odontocetes species were sighted at greater distance from active airgun arrays than during silent ones. During periods of active firing of the airguns, small odontocetes were more likely to show fast swimming behaviour (increase from 29% to 37% of encounters) and pods of harbour porpoises showed a stronger tendency to head away from the survey vessel than when the airguns were inactive (firing: 45% heading away, not firing: 30% heading away).

The different groups of marine mammals considered in this review apparently adopt different strategies for responding to the noise emitted by seismic arrays, with small odontocetes showing the greatest sensitivity.

The results presented by STONE (2003) indicate that water depth is a factor influencing the reactions of cetaceans to airgun operation (with stronger effects in shallow waters), therefore care must be taken when interpreting or transferring results from a study to assess the effects in another area.

### **NEDWELL et al. 1999:**

NEDWELL et al. (1999) found that there is a lack of carefully conducted and documented measurements of sound emissions during seismic surveys. For this reason, Texaco Britain plc assigned Subacoustech Ltd to conduct measurements of hydroacoustic noise during a 3D seismic survey. The study was carried out in July and August 1998 in the

North Sea at a water depth of 100 m, using an array of fourteen airguns of volumes between  $1200 \text{ cm}^3$  and  $6000 \text{ cm}^3$ , giving a total of  $54,700 \text{ cm}^3$  for the complete array. The measurements were conducted from a boat that was between 1400 m and 12 km away from the seismic array, drifting with the main engine shut off while the seismic vessel passed by. The recordings were taken at 5 m, 10 m and 20 m depth within a frequency range of 0.1 Hz to 95 kHz. A typical spectrum of the received signal is shown in Fig. 4.

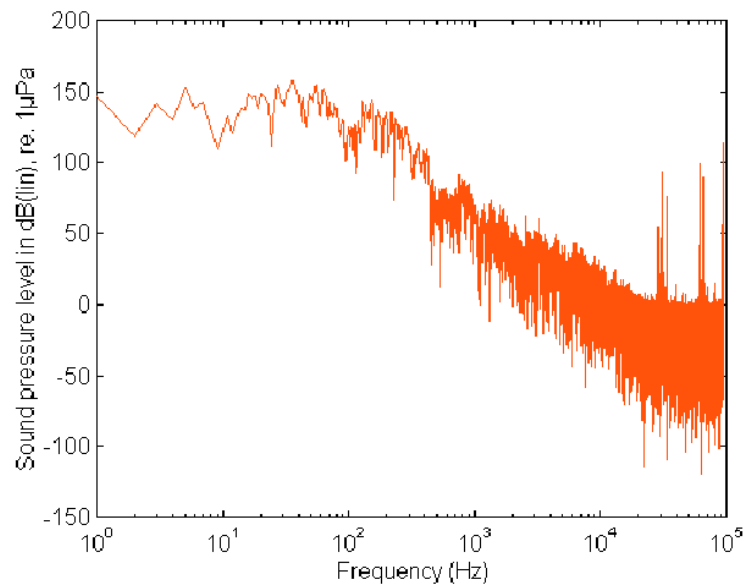

Fig. 4: Typical spectrum of the sound signal received during an impulse from the airgun array at 3000 m distance and 10 m depth (from: NEDWELL *et al.* 1999).

The authors emphasise that the values are highest when the measurement is taken at  $90^\circ$  to the direction of travel of the seismic boat, not only due to the distance being closest, but additionally because of the directionality of the emitted sound.

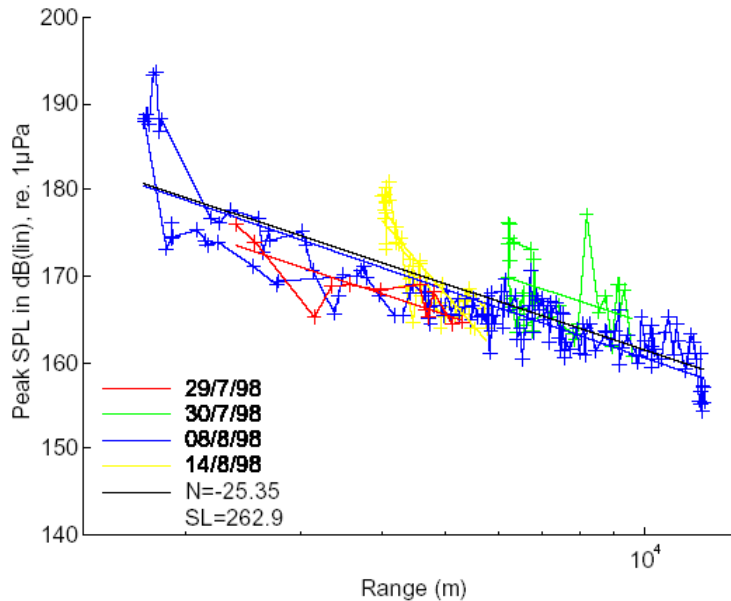

Fig. 5: Peak sound pressure level in dB re 1  $\mu$ Pa vs. distance from seismic array. The measurements were taken at 5 m depth (from: NEDWELL *et al.* 1999).

The distance of the closest measurement is not clearly given in Fig. 5, but derived from the report, it should be approx. 1,400 m. A source level of 262 dB re 1  $\mu$ Pa at 1 m is estimated by the authors, however, it is stated that the data background for this modelling could be refined by taking measurements over a greater span of range to decrease the error in describing the propagation loss.

#### **NEDWELL & HOWELL 2004:**

In their recent review, NEDWELL & HOWELL (2004) quote source level ranges between 216 and 232 dB re 1  $\mu$ Pa @ 1 m for individual airguns and from 235 to 259 dB re 1  $\mu$ Pa @ 1 m for airgun arrays (RICHARDSON *et al.* 1995) as the most reliable figures in the present literature. No substantial data for reactions of small (toothed) whales are reported.

#### **ASCOBANS 2003:**

In a resolution adopted by ASCOBANS (2003), the parties and nations are requested to introduce guidelines on measures and procedures for seismic surveys to

- (1) alter the timing of surveys or to minimise their duration;
- (2) reduce noise levels as far as practicable;
- (3) avoid starting surveys when cetaceans are known to be in the immediate vicinity;
- (4) introduce further measures in areas of particular importance to cetaceans;
- (5) develop a monitoring system that will enable adaptive management of seismic survey activities.

## Conclusion

In general, seismic studies to test the sea floor before the proposal or the actual construction of an offshore wind farm should be timed to reduce the likelihood of encounters with marine mammals during sensitive phases, such as the breeding or calving seasons (JOINT NATURE CONSERVATION COMMITTEE 2004).

To date, no data have been published on the effect of wind farm related seismic surveys on marine mammals. Studies investigating the behavioural effects of airguns on small cetaceans and seals in general are scarce. The few data that exist suggest that seismic studies used in wind farm site investigations should be a subject of concern (see FINNERAN *et al.* 2002) and that there is a need for further investigation (see also review by NEDWELL & HOWELL 2004).

## 8.2 SONAR

While seismic exploration aims at obtaining information on the structures of or within the bottom substrate (bottom penetration), sonar systems can also be arranged to depict objects in the water column (e.g. submarines, shoals of fish) or the bathymetry of the seafloor (depth sounding). This technique can be classified as low-frequency (<1000 Hz), medium-frequency (1-20 kHz) and high-frequency systems (>20 kHz) (HILDEBRAND 2004).

### PARSONS *et al.* 2000:

A short review was published by PARSONS *et al.* (2000), summarising possible interference between the numerous species of cetaceans, including the harbour porpoise, and the military activities in the waters off the western coast of Scotland. Submarine exercises and other military training activities often include the use of sonar. In numerous publications, this technology has been connected with mass strandings of Cuvier's beaked whales (*Ziphius cavirostris*), and was found to change the vocal behaviour of long-finned pilot whales (*Gobicephala melas*) (see literature cited in PARSONS *et al.* 2000). Frequencies commonly used by sonar systems and the respective source levels are listed in Table 2.

Table 2: Frequency ranges and average source levels of different sonar applications (from: PARSONS *et al.* 2000, see literature cited therein).

Sonar Type	Frequency Range (kHz)	Average Source Level (dB re 1 $\mu$ Pa / 1 m)
Search and surveillance	2-57	230+
Mine and obstacle avoidance	25-200	220+
Weapon mounted sonar	15-200	200+
Low Frequency Active Sonar (LFAS) used by NATO	0.25-3.0 ?	230+

Declines in sighting numbers observed by P. Evans of the Sea Watch Foundation (E.C.M. PARSONS, pers. comm.), suggested a temporary displacement of harbour porpoises as a reaction to a NATO training exercise (the Joint Maritime Course) in 1997, 1998 and 1999 in two different areas (cf. Figs. 6a & 6b).

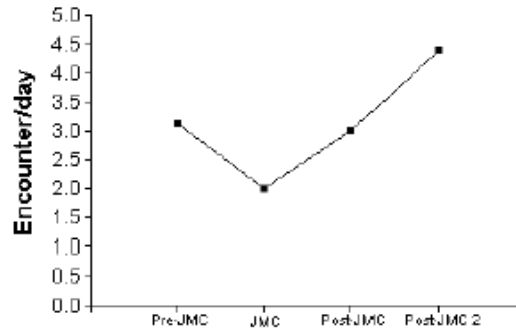

Fig. 6a: Harbour porpoise sighting rates near the Small Isles before, during and after the 1999 Joint Maritime Course (from: PARSONS *et al.* 2000).

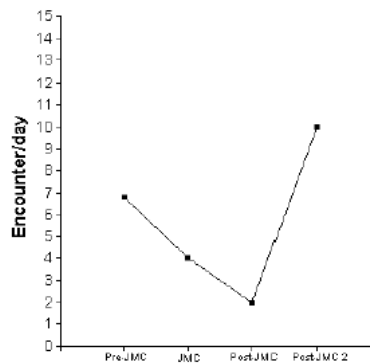

Fig. 6b: Harbour porpoise sighting rates in Gairloch before, during and after the 1998 Joint Maritime Course. (from: PARSONS *et al.* 2000).

## Conclusion

Military sonar operates at frequencies that cetaceans would be sensitive to. No data on the effect of wind farm related use of sonar on marine mammals exists to date. Information on commercially used sonars indicates that the frequencies are within the functional hearing spectrum of harbour porpoises and probably even seals. Observations from Scottish waters indicate a possible sensitivity of harbour porpoises to the use of active sonar, leading to temporary displacement. Further studies of the impacts of the use of sonar technology during the site investigation phase for offshore wind farms is needed.

## 9 Construction of Offshore Wind Farms: Noise Emitted and Effects on Marine Mammals

Various technical designs are used for the foundations of offshore wind turbines. The basic foundation types are monopile (e.g. Lely and Dronten off the Netherlands, Arklow Bank off Ireland, Utgrunden and Bockstigen off Sweden, Horns Rev off Denmark), multipile (e.g. the tripod at Nogersund, Svante, Sweden) or gravity foundation (e.g. the Danish wind farms at Middelgrunden, Vindeby, Tuno Knob and Nysted). The typical dimensions of these structures and the stages of the installation process are shown in Table 3.

Table 3: Foundation types used for offshore wind turbines, dimensions and sequence of installation tasks (from: OFFSHOREWINDENERGY 2004, <http://www.offshorewindenergy.org>)

Foundation type	Size (diameter)	Weight	Construction sequence
Gravity base	12-15 m	500-1000 t	1. Prepare Seabed 2. Placement 3. Infill Ballast
Monopile	3-3.5 m	175 t	1. Place Pile 2. Drive Pile
Multipile / Tripod	0.9	125 t	1. Place Base 2. Drive Piles
Bucket (caisson)	4-5 m	100 t	1. Place Base 2. Suction Installation

Each type of foundation is subject to different constraints and advantages. An advantage of the gravity base foundation is that the structure can be assembled onshore, thereby reducing offshore operations. Usually, no hammering action is needed. On soft bottoms, the monopile is easy to install with the proper equipment, but large stones in the seabed can make this difficult or even impossible (OFFSHOREWINDENERGY 2004, <http://www.offshorewindenergy.org> updated 11 Nov. 2004).

Offshore wind turbines are often based on monopile foundations that constitute a downward extension of the tower. To date, the dimensions of the deployed piles ranged from 2.1 m (Bockstigen, Sweden) to 4.2 m (Scroby Sands, UK) in diameter (OFFSHOREWINDENERGY 2004 <http://www.offshorewindenergy.org> updated 11 Nov. 2004, NEDWELL *et al.* 2003a). Pile foundations are put in place by driving with a hammer (impact or vibratory) or by drilling.

Since the construction of the first offshore wind farms in the 1990s, several studies on the emitted noise levels and the environmental effects of the construction of wind turbines or related research platforms have been conducted. The following review covers reports from the United Kingdom, Sweden, Denmark and Germany.



## 9.1 Noise Measurements

A comprehensive recommendation for best practice in conducting the noise measurements during the installation of wind turbines is given by DEWI *et al.* (2004). As pointed out in Chapter 7, the measurement should be conducted over a frequency range of up to 100 kHz. From a biological point of view, it should be emphasised that averaged values ( $L_{eq}$ , as suggested by DEWI *et al.* 2004) will be of limited use, while the peak levels and energy flux density of the impulses will be of interest. However, these can be obtained via a requirement that the raw data be saved for later analysis.

### United Kingdom

Underwater noise measurements of piling activities were taken at the construction sites of North Hoyle and Scroby Sands, beginning April 2003 (NEDWELL *et al.* 2003a). The period of impact pile driving was five and two months, respectively, placing thirty monopiles at each site with diameters of 4 to 4.2 m. At North Hoyle the average rate of blows was 35 per minute. The spectrograms, measured from distances between 1 and 4 km and given as  $1/27$  octave smoothed power spectral densities, revealed that most of the energy is between 40 Hz and 2 kHz (independent of distance to source), and that characteristic peaks were found at 200, 250, 600 800 and 1600 Hz. Based on own measurements, the transmission loss was found by  $22 \log(r)$ , where  $r$  = distance in m. The resulting source level (at 1 m) was 260 dB re 1  $\mu$ Pa at a depth of 5 m and 262 dB re 1  $\mu$ Pa at 10 m.

Measurements at Scroby Sands delivered sound levels and conclusions similar to those for North Hoyle. However, applying the much higher apparent local transmission loss of  $35 \log(r)$ , where  $r$  = distance in m, a source level of 297 dB re 1  $\mu$ Pa at 1 m was calculated. The validity of this source level is questioned by the authors, emphasising the need for careful consideration of local bathymetric features manifested in the unusual apparent transmission loss.

Rock socket drilling was conducted at North Hoyle, where the seabed substrate is mainly hard rock. About 20 hrs. of drilling were required to prepare the placement of each pile. Over 100 Hz significant tonal component have been detected with strong peaks at approx. 125, 250 and 375 Hz. The maximum power spectral density levels, measured 160 m from the sound source, were at approx. 100 to 115 dB re 1  $\mu$ Pa<sup>2</sup>/Hz (representing 5 to 15 dB above background noise). Potentially present lower frequency peaks may have been smeared by the bandwidth of 1 Hz. Some evidence of narrow peaks at frequencies of up to 8 kHz could be seen. The authors summarise that tonal noise could be detected above broadband background noise at a distance of up to 7 km from the drilling site. Due to high variability of recorded levels, no value for the transmission loss, and hence no estimate for the source level, are given.

### Sweden

ØDEGAARD & DANNESKIOLD-SAMSØE (2000) conducted noise measurements in September 2000 during the installation of one monopile at a wind farm site in Sweden, located between the mainland and Öland. The ramming impact rates increased throughout the 1.5 hour ramming period for the placement of the pile from 2 to 24 impacts per minute. All in all 1320 impacts were counted. Measurements were taken in air (16 Hz to 20 kHz) and underwater (1 Hz to 20 kHz), the analysis is based on  $1/3$  octave band sound pressure levels.

At the closest distance given for underwater measurements (30 m from sound source), the ramming impulses reached a level of 203 dB re 1  $\mu$ Pa. On average, the more than 1000 impacts resulted in an SPL of 176 to 184 dB re 1  $\mu$ Pa at frequencies between 160 and 500 Hz (hydrophones placed mid-water at a depth of 2-3 m). Assuming a spread loss of  $15 \log(r)$  where  $r$  = distance in m, or 4.5 dB per doubling in distance, this results in a maximum SPL of 225 dB re 1  $\mu$ Pa, and average values between 198 and 206 dB re 1  $\mu$ Pa. In air measurements taken 320 m downwind from the pile, the average linear  $1/3$  octave band sound exposure level was below 90 dB re 20  $\mu$ Pa for all frequencies recorded.

The authors conclude that at frequencies below 4 Hz, the underwater sound of the pile driving impacts is below the background noise level at the distance of measurement (320 m), whereas at higher frequencies, ramming sound levels are above ambient noise levels.

From a biological point of view, it seems more important to focus on the energy of the signal and the maximum SPL reached during construction, as single acoustic events can provide sufficient energy to cause auditory impairment to an animal exposed to the sound.

## Germany

BETKE *et al.* (2004) and SCHULTZ VON GLAHN & BETKE (2003) present results obtained from sound measurements during the ramming activities for the FINO 1 research platform at the planned Borkum-Riff wind farm site in July 2002. This research platform was set up in the North Sea to determine, among other things, the possible effects of future offshore wind turbines on the marine flora and fauna. The measurements were taken during ramming of one of the four piles (1.5 m in diameter and 36.5 m in length).

At frequencies higher than 30 Hz, the noise level of the pile driving was above measured background levels at a distance from the sound source of 400 m. At the same distance, the maximum sound pressure (given in 1 Hz band width) of 150 dB re 1  $\mu$ Pa was recorded at a frequency of approx. 110 Hz, with several other peaks in the range between 200 Hz and 1 kHz.

The sound exposure level calculated to source level (1 m distance) revealed peaks of 195 to 200 dB re 1  $\mu$ Pa at 125, 275 and 1000 Hz. The values are normalised to an event duration of 1 second. The authors emphasise that this leads to an underestimation of the maximum sound pressure perceived by marine animals, due to the much shorter duration of a single ramming impulse.

The report of the DEWI *et al.* (2004) refers partly to the same data as BETKE *et al.* (2004) and SCHULTZ VON GLAHN & BETKE (2003), but also compares these results to additional parallel measurements and to results obtained during the construction of the GEO research platform at the site of the SKY 2000 wind farm in the Baltic Sea.

The parallel measurements at FINO 1 conducted by researchers of two different institutes (DEWI and ITAP) resulted in values differing by approx. 6 dB. The reason for this deviation is seen in differences not only in the distances (350 and 400 m, respectively), but also in the depths of the hydrophones, and the directions from the source (parts of the structure blocked the sound propagation in certain sectors). The latter two factors are emphasised by the authors as important parameters to be considered in future investigations.

In December 2002, measurements were taken during placement of the single pile for the GEO platform (3 m in diameter). The characteristics of the spectrum and the order of magnitude of the levels were similar to the results obtained from FINO 1.

Ramming of the FINO 1 pile took approx. 2 hours, with 0.9 strokes per second in the beginning and 0.7 strokes per second at the end. In the course of the ramming the noise level increased from 4 to 6 dB, probably due to the increasing penetration depth of the pile tip and/or to stratification within the substrate.

ZIELKE *et al.* (2004) present models developed in the GIGAWIND research project to estimate the noise emission from offshore wind turbine construction. Initial comparisons of the calculated noise levels with results of actual impact pile driving measurements (those reported above) showed promising correspondence. The calculated maximum sound pressure level of the impact driving of a FINO 1-type pile was 200 dB at a distance of 15 m from the source at a frequency range of 0 to 400 Hz. A further model revealed that use of the vibration pile driving technique would have reduced the sound level by approx. 25 dB.

## Denmark

Noise measurements were also conducted during the construction of the wind turbines at Horns Rev, Denmark (TECH-WISE 2002), yielding a spectrum of noise of up to 100 kHz. The recordings were made at a distance of  $\frac{1}{8}$ ,  $\frac{1}{4}$ ,  $\frac{1}{2}$  and 1 nautical mile (nm) from the wind turbine. At  $\frac{1}{8}$  nm distance, a maximum sound pressure level of 191 dB re 1  $\mu$ Pa was measured. Most of the energy was concentrated within the low-frequency portion of the recorded signals. As the frequency analysis had an upper limit of 100 kHz, an even wider frequency spectrum of sound emissions cannot be ruled out.

## Conclusion

The sound recordings undertaken to date are useful for an understanding of the acoustic dimensions of wind turbine related noise. Based on existing sound measurements of operating wind turbines, it is unlikely that there will be an acoustic overlap between adjacent wind farms. On the other hand, in case of simultaneous installation of wind turbines at different wind farm sites, a cumulative effect is very likely, as the sound emissions related to the construction of the turbines can be perceived over very long distances.

To date however, only a limited amount of information can be drawn from these recordings, as they were generally made with foundation types and sizes at different water depths and locations. This results in significantly different sound pressure levels and spectral densities, especially with regard to differing bottom substrate. Systematically conducting further recordings during all phases (pre-, construction and operational phase of wind turbines) will be one of the research needs.

## 9.2 Effects on Marine Mammals

### United Kingdom

NEDWELL *et al.* (2003a) evaluated results from noise measurements during impulsive pile driving (see chapter 9.1). Applying the dB<sub>ht</sub> perception units (see chapter 6.4) the authors assessed that avoidance reactions from harbour porpoises and harbour seals should be expected at ranges of 7,400 and 2,000 m, respectively. At a closer range (within approx. 77 m) the impacts could cause moderately severe blast-type injuries to marine mammals, including eardrum ruptures.

For drilling operations however, the relatively low noise level is presumed to cause no environmental impact. The latter assumption is based on the fact that at distances greater than 100 m, the noise converted to perception units (see Chapter 6.4) for harbour porpoises, harbour seals and several fish species is below 90 dB<sub>ht</sub>, the threshold at which a significant avoidance reaction can be expected. Due to high variability of recorded levels, no value for transmission loss, and hence no estimate for the source level, are given.

However, as noted in Chapter 4.4, the dB<sub>ht</sub> scale is species specific and reflects the varying sensitivities of animals' ears at different frequencies. Since for most species of concern, only one or a few animals have been tested for hearing sensitivity, this approach lacks the its most fundamental information for usefulness. Its premature use could thus suggest a precision and declarative strength that does not exist yet.

### Sweden

SUNDBERG & SÖDERMAN (1999) analysed the impact of five offshore wind turbines on two grey seal haul-out sites (Killingholm and Näsrevet) off Gotland (Swedish Baltic Sea). Land-based counts of animals on land and in the water were conducted. In addition to previous information on grey seal abundance, data in seal numbers were regularly collected from the summer of 1996 (initial project stage) through the autumn of 1997 (construction phase).

During the entire monitoring period, which also lasted beyond construction into the operational phase of the wind farm (see Chapter 11.2), a considerable variation in seal presence at the haul-out sites was observed. While the authors found evidence that the grey seals were affected on a short-term basis by wind farm related helicopter and boat traffic (see Chapter 13), the variation in numbers on a greater time scale was rather linked to such meteorological variables as strong winds and unfavourable water conditions.

### Germany

SCHULTZ VON GLAHN & BETKE (2003) presented the same measurements as BETKE *et al.* (2004) from the construction of the FINO 1 platform. The authors state that the values for sound exposure levels (>195 dB re 1 µPa at 125 - 1000 Hz) should not be placed in relation to the hearing thresholds of marine animals without adding a correction factor, since the much shorter single impulse of ramming noise is "diluted" by the process of normalising to one second periods, so that maximum sound pressure is underestimated. A careful estimate of a temporary physical impact (TTS) range of about 1 km around the ramming site is given for harbour porpoises.

## Denmark

### *Seals in the Baltic Sea*

The Nysted offshore wind farm was constructed during 2002 and 2003 in the vicinity of the Rødsand seal sanctuary, which supports a closed population of relatively stationary harbour seals. Monthly aerial surveys of Rødsand and nearby, possibly alternative haul-out sites have been evaluated in TEILMANN *et al.* (2004a). During the construction of the wind turbines, Rødsand remained the most important haul-out site in the area referring to the summer months, but was seen as less important from October to March. Comparison between baseline and construction phase data showed no significant shift of seals at Rødsand relative to the other haul-out sites. The authors concluded that, based on aerial surveys, there were no indications that the construction activities had affected the local Rødsand population differently from other population fluctuations in the south-western Baltic Sea.

Parallel to the visual monitoring described above, a remote video system was installed at Rødsand to record haul-out numbers of harbour seals during daylight hours (EDRÉN *et al.* 2004a). The system stored images every 5 seconds. The first phase of construction work at the wind farm site, mostly excavation with low noise levels at distances of 4 km or more from the haul-out site, started before the camera system was operational. Activities with higher sound emission (sheet pile vibration for periods of 1 to 10 hours) did not start until mid-August 2002, and the authors considered the previous images baseline data. Vibratory sheet driving was carried out for only a single wind turbine foundation located 10 km from the sanctuary (the other foundations are of the gravitational type). Vibratory driving ceased in November 2002. By comparing periods within each of these months with and without vibratory piling activities, the authors determined that this sound source caused a significant decrease in the number of seals on land during periods of active vibratory driving (observed reduction between 8.4 and 100%). The least effect was found during the moulting period in August, when the seals are strongly attached to land. The strongest effect was observed in November, where no seal was observed on land during sheet driving. The authors state that the noise of vibratory piling may have been audible to the seals at Rødsand, both on land and in the water. With the methodology used here, the reaction of the animals in the water remained concealed. Except for the short-term effect during vibratory sheet driving, the data from this study suggests that there is no overall impact from the construction of the Nysted wind farm on harbour seals at Rødsand.

The same results are also presented in the summarising report by ENERGI E2 (2004).

### *Porpoises in the Baltic Sea*

The construction work for the Nysted offshore wind farm described above was conducted in an area that is, based on regular sightings of adult harbour porpoises and calves, relatively important for this species, as reviewed by HENRIKSEN *et al.* (2003). The authors report on the results of an acoustic survey conducted with stationary PODs to evaluate potential effects of construction work on the presence of harbour porpoises in the area. The echolocation activity was monitored year-round at the wind farm site as well as in a reference area approx. 10 km further east, for a BACI (Before-After-Control-Impact) analysis. The authors concluded that there had been a significant effect from the first months of construction of the wind farm, when the echolocation activity in the wind farm area decreased compared to the reference area. In reaction to the particularly noisy vibratory sheet driving, a very distinct and significant decrease in echolocation

activity was found in the wind farm area as well as in the reference area. HENRIKSEN *et al.* (2004) found that the mean waiting times increased from 8 hours in the baseline period to almost 3 days in the wind farm area during the construction period. This increase was 5.5 times larger relative to the changes observed in the reference area. One specific construction activity, ramming and vibration of steel sheet piles into the seabed, was associated with significant waiting time increases of 4 – 41 hours, in both the construction and reference area. The authors conclude that, since for harbour porpoises, echolocation is the primary sense used for orientation, the decrease in recorded echolocation activity can be correlated with an authentic decrease in the presence of this species. It was concluded that the construction had created a measurable, temporary decrease in the activity of harbour porpoises in the area.

In continuation of the previously described study, HENRIKSEN *et al.* (2004) reported a decrease in echolocation activity of harbour porpoises in the wind farm area and also a slight increase in activity in the reference area. They come to the conclusion that during the construction phase, most harbour porpoises avoided the vicinity of the wind farm, site probably due to noise disturbance or lack of appropriate food, which constituted a significant effect.

Even though a slight recovery from the disturbance effect during the construction phase is assumed (TOUGAARD & TEILMANN, 2004), the POD studies in the first half of 2004 reveal that the click activity has not returned to the level of the baseline studies. This probably reflects a decrease in the number of harbour porpoises present in the study area.

### *Porpoises in the North Sea*

TOUGAARD *et al.* (2003A) reported on the results from monitoring harbour porpoises in the Danish North Sea (Horns Rev area) between March 2002 and March 2003. This study was part of an ongoing programme designed for a BACI analysis to assess the effects of wind farm construction on the behaviour and abundance of harbour porpoises. In addition to the immediate area of the wind farm, three control areas were defined as references. Data collection was conducted via visual ship-based surveys, and via stationary and towed PODs. At distances of up to 20 km (11 nm) from the site, behavioural effects reported showed a decrease in non-directional swimming, which is assumed to correlate with feeding behaviour. During the ramming of the steel monopile foundations, the acoustic activity of harbour porpoises recorded by the PODs decreased sharply, and returned to higher levels within a few hours after ramming ceased (short-term effect). This effect was observed throughout the Horns Rev area, i.e. even in the reference areas, and was attributed by the authors to the ramming. However, the authors also stated that the lower abundance, that was visually and acoustically observed could be due to general temporal variations in harbour porpoise densities in this part of the North Sea.

Analysing results from the same area obtained between February and October 2003 (i.e. some overlap in data with the report mentioned above), the same authors (TOUGAARD *et al.* 2004) came to somewhat different conclusions. The POD data showed a pronounced effect from the construction work for the wind farm, as encounter duration increased and waiting time between detection decreased. Both parameters seemed to indicate higher levels of porpoise activity during construction than during previous baseline studies, which is contrary to the expected effect. The authors suggest a possible attraction effect resulting from increased prey abundance caused by the construction work.

### *Seals in the North Sea*

TOUGAARD *et al.* (2003B) conducted a study on the dispersal behaviour of ten harbour seals in the North Sea equipped with satellite transmitters. The animals were caught on the island of Rømø between January and May 2002. Based on former VHF studies, it was expected that the animals would spend a considerable share of their time in the Horns Rev area, where an offshore wind farm was built the same year. However, the positional data from the deployed satellite transmitters revealed a much higher mobility and a higher level of individual variability in movement patterns and distances than foreseen, and the Horns Rev area itself represented only a negligible fraction of the total area visited. Nevertheless, the authors state that Horns Rev represents an important area for harbour seals for foraging and especially for transit between their haul-out site and their offshore feeding grounds. Of the eight animals considered representative within this study, three seals did move across the Horns Rev area during the constructional phase of the wind farm, when monopiles were rammed into the seabed; however, none of them seemed to spend any considerable time at the wind farm site. Unfortunately, the resolution of the satellite location data was insufficient for any detailed statement on the effect of the construction work on the tagged animals.

### **Conclusion**

As discussed in Chapter 4.4, it currently seems inappropriate to apply the  $dB_{ht}$  scale as suggested by Nedwell *et al.* (2003a). And it seems even more unrealistic to predict the behavioural thresholds of marine mammals, since whether or not an animal will show a certain reaction depends on several factors, such as age, sex and especially motivational status. The same general problem arises with a correction factor as suggested by SCHULTZ VON GLAHN & BETKE (2003) and BETKE *et al.* (2004). As stated by the authors, any attempt to draw conclusions regarding the behaviour of the marine mammals from these measured values would be highly questionable.

The Swedish study provides useful data on the haul-out behaviour of grey seals in the vicinity of a wind farm. However, no conclusions can be drawn on the underwater behaviour of these animals.

The Danish studies provide the most useful data so far on the effect of offshore wind turbines on marine mammals, as numerous studies are linked and well coordinated. These studies cover the most important research topics in relation to offshore wind farms. The data acquisition was designed to gather the relevant data in a format which would allow the conduct of a BACI analysis. As it turned out, many technical and logistical problems had to be solved, and due to some changes or a lack of data or funding, such a BACI analysis will probably not be feasible for all aspects.

### *Seals:*

With respect to aerial counts, it remains unclear whether the chosen parameters are enough to draw a conclusion about the impact of construction activities and the presence of the wind farm on the local Nysted population. It might be more appropriate to include comparable data from sandbanks in adjacent areas in the analysis, if a general trend were identified. In this context the conclusions drawn from the video data gathered at the Nysted sandbank might also have less declarative strength than stated by the authors. The telemetry studies at both Danish wind farm sites revealed valuable information, but the number of animals tagged at both sites remains rather low for any

final conclusions about the impact of the construction and presence of the wind turbines. In order to evaluate these effects, it would be necessary to collect more detailed behavioural data.

#### *Porpoises:*

The results of the Danish studies clearly indicate that the construction of wind turbines has an immediate negative effect on the abundance of harbour porpoises in the wind farm areas.

However, even though this decrease in harbour porpoise abundance could be observed during ramming activities at both sites, its duration and extent during the entire construction period can differ significantly between different sites, as observed in the two Danish studies. While the effects were temporary at one of the sites, they must be considered provisional, or relevant for long-term effects, at the other. It remains unclear whether these differences are density dependent, or potentially reflect a general difference in the use of the investigated habitat that exists in the populations at these sites. Moreover the observed differences can also be attributed to other biotic as well as abiotic parameters (e.g. changes in prey availability and/or increased shipping activity). In order to evaluate these correlations, the data set would have to be even more comprehensive, and be analysed in greater detail.

Given these so far inconclusive results, any transfer of conclusions on the effect of the construction – except for the immediate effects of the pile driving – from one wind farm site to another must be treated with caution.

## **10 Other Offshore Construction: Noise Emitted and Effects on Marine Mammals**

While the construction of wind farms is a relative new sector in the broad field of human offshore activity, the installation of such other structures as piers or oil and gas platforms has existed for centuries or at least decades. Thus, the experience and results obtained from such construction can be helpful in assessing acoustic impacts during the placement of wind turbine foundations. Oil and gas platforms are usually supported by at least three to four legs, each consisting either of a single pile or several skirt piles around each leg. The piles are hollow steel tubes ranging in diameter from 914 mm to 2743 mm. For the construction of near-shore marine structures (e.g. jetties), piles of greater diameter are generally used. Placement of the piles is conducted either by driving with impact or vibration hammers or drilling. Also, gravity foundations are used for oil platform constructions, especially in the Norwegian waters of the North Sea (OFFSHOREWINDENERGY 2004). Besides actual pile driving activities, this Chapter also addresses other such potentially relevant techniques as dredging, trenching or drilling. As the propagation and therefore the effects of sound depend on the oceanographic features of the construction site, only studies referring to shallow water installations have been considered, thus enhancing the applicability of the results cited for the present field of interest.



## 10.1 Pile Driving Activities

### WÜRSIG *et al.* 2000:

WÜRSIG *et al.* (2000) report on the results of sound level measurements conducted during the construction work for an aviation fuel receiving facility for the Hong Kong International Airport. Impact driving of the pile footings of the facility took place at water depths of between 6 and 8 meters, using a 6 tonne diesel hammer. Blow rates were between 57 and 81 strokes per minute. Measurements were taken within a frequency range of 100 Hz and 50 kHz, simultaneously from three boats at distances of 250, 500 and 1000 m from the source. The hydrophones were placed at a depth of 6 m in a water depth of 8 m. The highest sound level measured at a distance of 250 m from the source was 170 dB<sub>rms</sub> re 1 µPa (octave band level); assuming a cylindrical spread, this results in a source level of 218 dB<sub>rms</sub> re 1 µPa. This maximum level occurred at a frequency of 400 Hz.

### WOODS *et al.* 2001, CALTRANS 2001:

In preparation of the major construction work for the new San Francisco-Oakland Bay Bridge (SFOBB) a Pile Installation Demonstration Project (PIDP) was conducted by the California Department of Transportation (Caltrans) between October 23 and December 12, 2000, as described in WOODS *et al.* (2001) and CALTRANS (2001). The purpose of the PIDP was to gather the information that was necessary to obtain the required environmental permits and, as described in Chapter 14.3 below, to investigate the effectiveness of bubble curtains as a sound pressure mitigation technique. Both aspects included the monitoring of the effects on marine mammals. Demonstrational pile driving was conducted by ramming three steel pipe piles, each measuring 2.57 m in outside diameter, at two different locations adjacent to the eastern span of the existing SFOBB, using two different sizes of hydraulic hammers (500 kJ and 1700 kJ, respectively). Overall, the PIDP involved 12 hours and 51 minutes of pile driving. The water depth for PIDP is not reported systematically, but around Pile 3, it is stated as being between 5 and 7.5 m, for the overall SFOBB construction project, the range was between 18 m and 0.3 m.

During driving of the first pile measurements, the sound pressures were measured at distances of 103 and 358 m, at depths of 1 and 6 m (Table 4).

Table 4: Sound pressure levels measured during ramming activities of pile 1 during the PIDP (units in dB re 1 µPa), applying a hammer energy between 900 and 1300 kJ.

<i>istance</i>	<i>RMS (impulse), depth of measurement 1 m</i>	<i>RMS (impulse), depth of measurement 6 m</i>	<i>Linear peak</i>
103 m	185 dB	196 dB	197-207 dB
358 m	167 dB	179 dB	181-191 dB

A spreading loss of 30 dB per tenfold increase in distance was calculated for distances between 100 and 350 m (REYFF 2003, citing GREENE 2001). Due to this limitation, it would inappropriate to calculate the source levels.

Pacific harbour seals (*Phoca vitulina richardsi*) and California sea lions (*Zalophus californianus*) forage in the San Francisco Bay year-round (Fig. 7). While sea lions have not been observed to reproduce within the San Francisco Bay, harbour seal breeding

season in this area lasts from March through May, and nursing duration is four weeks. Mating occurs from April to July, and the moulting season is from June through August. Grey whales (*Eschrichtius robustus*) can be observed in the Bay area from December through March. Due to the potential disturbance of marine mammals caused by the pile driving work, the NMFS decided on an initial MMSZ of 500 m around the ramming site. This safety zone was subject to further adjustment based on the results of the noise measurements, which enabled determination of the actual contour of the valid threshold of 190 dB re 1  $\mu$ Pa (CALTRANS 2001).

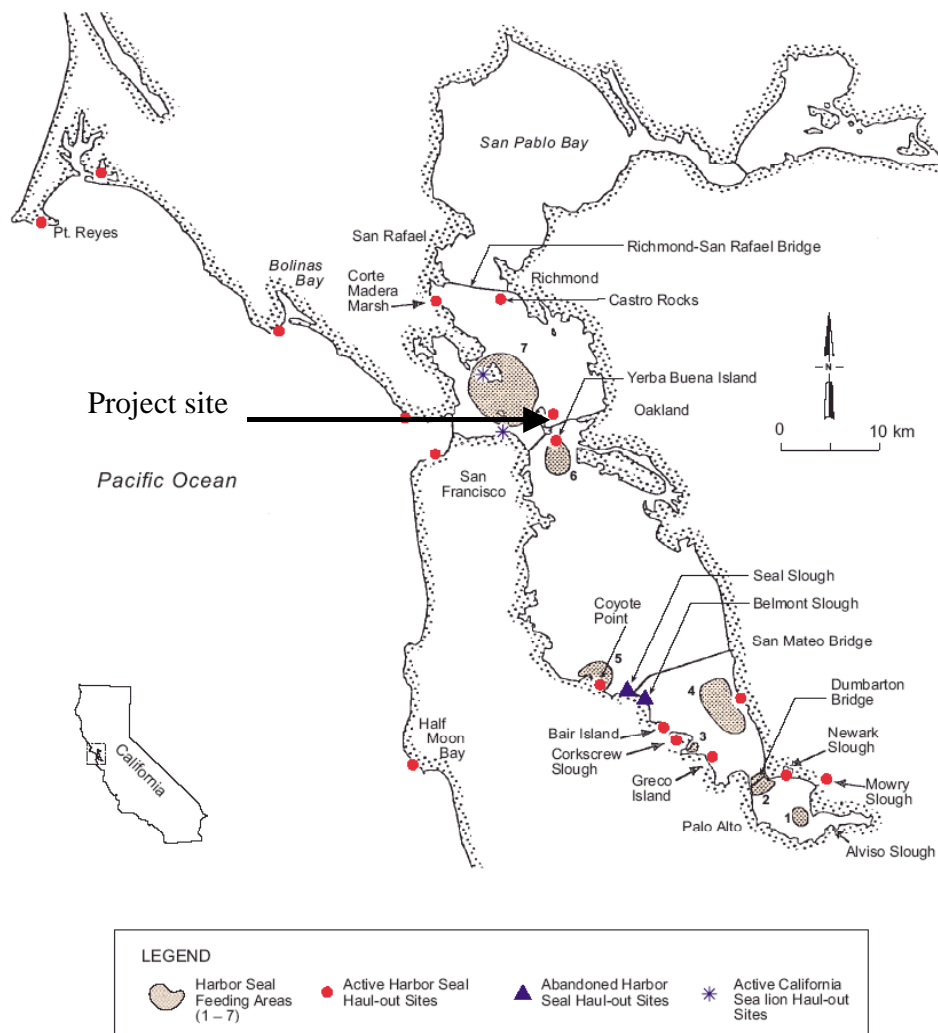

Fig. 7 Harbour seal and California sea lion (*Zalophus californianus*) haul-out sites and feeding areas in the San Francisco Bay area (from CALTRANS 2001). The location of the San Francisco-Oakland Bay Bridge (SFOBB, black line) and the Pile Installation Demonstration Project (PIDP) is marked by the big arrow.

Marine mammal monitoring during pile driving was conducted within the initial 500 m MMSZ and at the nearby Yerba Buena Island (YBI) haul-out site, located approx. 1500 m from the pile driving area (see Fig. 7). Table 5 lists the marine mammals observed in the water during the construction period. In addition, up to eighty-five harbour seals were observed at the haul-out site YBI.

Table 5: Number of marine mammals observed in the water during the construction period for the PIDP.

<i>Species</i>	<i>Total number of sightings</i>	<i>Sightings during pile driving</i>	<i>Sightings near construction site during pile driving</i>
Harbour seal	55	47	8
California sea lion	13	10	3
Grey whale	-	-	-

Based on the observations of behaviour, the authors found no harbour seals, either swimming or hauled-out, to be affected by the pile driving noise. Individuals at the haul-out site were found to respond only to such non-ramming-related factors as tides, helicopters or boats (in particular kayaks), with changed haul-out numbers, alertness or flushing of the site.

The three California sea lions seen near the site reacted to the pile driving noise by rapidly swimming away from the sound source, regardless of whether the small or large hammer was used or whether sound attenuation devices were in operation. These observations were made on three separate days. One affected animal was reported at a distance of 1000 m from the pile driving site, indicating that the noise level far outside the MMSZ was still of a magnitude that could startle a sea lion.

Despite the observed reaction of the California sea lion, based on the results of the noise measurements, the initial 500 m-MMSZ was recalculated to be 185 m for a hammer energy level of 750 kJ and 285 m for strikes of 1750 kJ (see also chapter 6.3). The effect of the bubble curtains concerning further reduction of the 190 dB re 1  $\mu$ Pa-contour is cited in Chapter 14.3, below.

The authors assume that in addition to the frequency, the duration of the noise could also play a role in the observed effects on marine mammals. It was concluded that the longer duration of the pile driving during the actual construction of the SFOBB, when many more piles are installed than during the demonstration project, may have caused, at minimum, a temporary displacement of some pinnipeds (CALTRANS 2001).

#### **REYFF 2003, THORSON & GOLDSTEIN 2002:**

REYFF (2003) reported on the noise measurements during the re-strike of three PIDP piles in December 2002, carried out to conduct a geotechnical evaluation of the piles and to test the performance of sound mitigation systems (cited in Chapter 14.3, below) by comparing underwater noise measurements with and without the system operating. In this Chapter only the unattenuated maximum values are cited. Observations of marine mammals were conducted on the two days of pile re-striking. All piles were driven at a blow rate of approx. 30 strokes per minute with a hammer energy between 1500 to 1700 kJ. Measurements were taken at various distances and depths. The maximum noise levels registered were 197 to 211 dB re 1 $\mu$ Pa (peak pressure) 100 m from the source, and 182 to 195 dB re 1 $\mu$ Pa (rms sound pressure levels; maximum values measured at frequencies below 1 kHz) at the same distance from the strike site. Peak pressures were found to vary considerably based on the direction from which the measurement was taken, with the sound signal being carried further in the direction of the current (which was weak) than against it (e.g. comparable levels 100 m down-current and 65 m up-current).

The results of the marine mammal observations during the re-striking activities are reported by THORSON & GOLDSTEIN (2002). The authors summarise that during the monitoring periods (9 a.m. to 3 p.m. and 9:30 a.m. to 11:45 a.m. local time) on the two days of pile driving, only six harbour seals and two California sea lions were sighted swimming within 1000 m of the pile striking site. All sightings were before or after active pile striking periods, and it was concluded that there was no impact on swimming marine mammals caused by the re-striking of the PIDP piles. The numbers of hauled-out harbour seals at YBI on the two days were 0 and 12, respectively, and there was no reaction to the pile driving noise observed.

#### **THORSON & REYFF 2004, THORSON 2004:**

During the construction of the San Francisco-Oakland Bay Bridge (SFOBB) a total of 160 piles, measuring 2.6 m in diameter, was driven into the sea-bed in water depths between 0.3 and 18 m. Initial construction work began at the end of July 2002 (mainly dredging, see also Chapter 10.2) and impact driving of large piles was completed by February 2004.

THORSON & REYFF (2004) describe the results of sound measurements and marine mammal monitoring conducted between November 2003 and February 2004. Results obtained with sound mitigation measures within the SFOBB project are cited in detail in Chapters 14.3 and 14.5 below, and address techniques of attenuation itself. The sound measurements conducted aimed at establishing MMSZs for cetaceans and pinnipeds respectively, along the 180 and 190 dB re 1  $\mu$ Pa contour around the work site. Measured noise levels without sound mitigation are not reported in detail, but are stated as being between 5 to 20 dB above the attenuated levels (using the bubble curtain described in Chapter 14.3), which reached a maximum of 206 dB re 1  $\mu$ Pa (peak level) or 195 dB re 1  $\mu$ Pa ( $RMS_{impulse}$ ), both at a distance of 50 m.

Marine mammal monitoring was conducted from the pile driving barge (one observer) as well as at the YBI and Point Bonita haul-out sites (two observers). While YBI is in the vicinity of the construction site, i.e. 1300 to 2200 m from the piles driven, Point Bonita, located 45 km from the pile driving activities for SFOBB, and not affected by the ramming noise, was chosen as a reference site which. At YBI up to 194 Pacific harbour seals were observed hauled out, and at Point Bonita the maximum count was 47 individuals. The latter were mainly disturbed by high swells which washed them off the rocks, and by fishermen who ignored the prohibited access to the beach. Among seals at the YBI haul-out site, little or no reaction to the pile driving noise was observed; on only two occasions did single animals show a head-lifting response. As found previously in the report on the PIDP (CALTRANS 2001), the main disturbances of the harbour seals at the haul-out sites were caused by traffic on the existing bridge, aircrafts passing overhead and approaches by boaters or kayakers.

With the exception of two days when runs of spawning herrings observed in the area, few marine mammals were sighted in the vicinity of the construction site (see Table 6), as was reported in the baseline study in 2003 and the PIDP (CALTRANS 2001). The authors summarise that observed Pacific harbour seals and California sea lions showed no signs of disturbance due to the construction work.

Table 6: Numbers of marine mammals observed during the construction of the eastbound structure of the SFOBB. Distances given refer to distance from the site of pile driving.

Species	observed at a distance of 150 to 500 m	observed within MMSZ (<100 m distance)
Pacific harbour seal	11	2
California sea lion	2	1
Grey whale	-	-

The three animals within the MMSZ showed no startle reaction (e.g. fast swimming at the surface) in response to the continued active pile driving.

### VAGLE 2003:

VAGLE (2003) summarised the results of acoustical measurements conducted during several pile driving projects in Canada. Here, only the data of the Vancouver Harbour Project, undertaken in the summer of 2000, will be cited, as the other activities took place in fresh water (lakes and rivers). At Canada Place in the inner harbour of Vancouver, several steel piles 91 cm in diameter were driven using a diesel impact hammer. The amount of data is very limited, but the example provided a maximum sound pressure level greater than 150 dB re  $1\mu\text{Pa}^2/\text{Hz}$ . As the distance to the source is not clear, the source level cannot be calculated with this data.

### NEDWELL *et al.* (2003 b):

NEDWELL *et al.* (2003b) presents the results of sound measurements during the pile driving for a ferry terminal in Southampton, UK, in September 2003. The specification of the piles, the technique of pile driving used and the distances between measuring points and the piling site are shown in Table 7 and Table 8.

Table 7: Distances of measurement locations from piling site (from: NEDWELL *et al.* 2003b).

Location	Distance (m)
R3	96.3
R4	233.8
R5	417.4

Table 8: Specification of piles, driving techniques and distance of sound level measurements from piling site (from: NEDWELL *et al.* 2003b); vibro = vibratory pile driving, impact = impact pile driving.

Pile number	Pile diameter (mm)	Type of driving	Measurement position
2	914	vibro	R5
3	914	vibro	R5
4	914	vibro	R5
5	508	vibro	R5
6	508	vibro	R5
7	508	vibro	R5
8	508	vibro	R5
9	508	vibro	between R4 & R5
10	508	vibro	R3
1	914	impact	R3
6	508	impact	R3
9	508	impact	R3

Vibratory piling was conducted using a PVE 2316 VM driver. Fig. 8 shows the hydraulic drop hammer BSP357/9 used for impact driving.



Fig. 8: The PVE 2316 VM driver used for vibratory pile driving (from: Nedwell et al. 2003b).

Sound level measurements during vibratory driving show several peaks over the time of activity, that, however, were associated with the passages of vessels along the close-by, busy waterway and into the ferry terminal (Fig. 9).

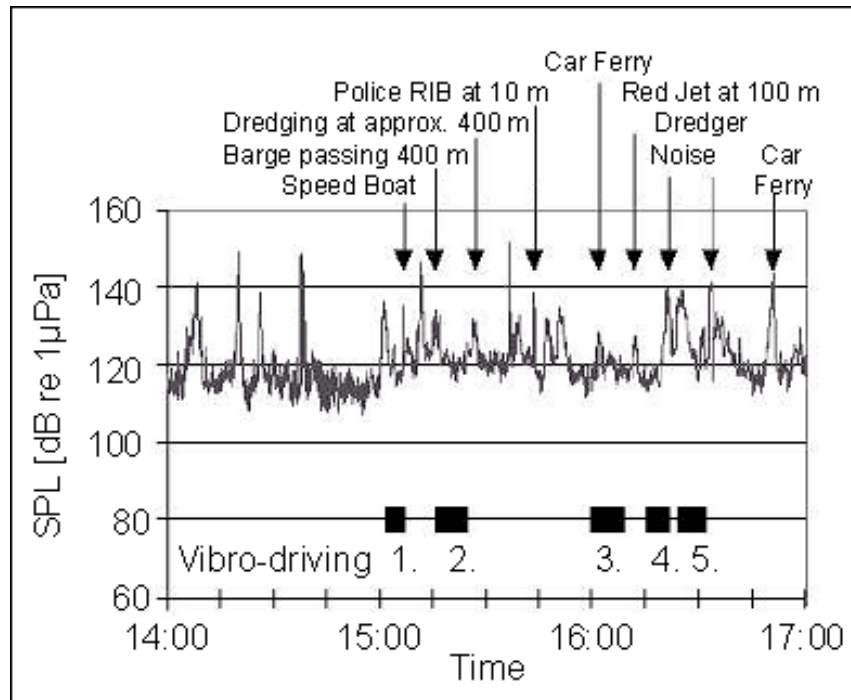

Fig. 9: A typical sound pressure level vs. time history obtained at a distance of 417 m from the piling during the use of a vibratory driving device. Times of active vibratory pile driving are marked black, arrows show boat passages and noise during the measurements (after: NEDWELL *et al.* 2003b).

The authors concluded that at a distance of 417 m, there was no discernable contribution from the piling activities above background noise level. During impact piling, impulsive high level sound was registered (peak-to-peak pressure of about 200 Pa). The variation of signals with the distance from the construction site yielded a transmission loss of 0.15 dB/m and a source level of 194.3 dB re 1  $\mu$ Pa in 1 m. Given average background noise of 120 dB re 1  $\mu$ Pa in 1 m and applying the same transmission loss as during the pile driving, this would result in a source level of approx. 183 dB re 1  $\mu$ Pa in 1 m (no information on frequency given).

## 10.2 Dredging

To date, dredging has not been among the major activities during the construction of offshore wind farms, and has received less attention than e.g. pile driving and its impact. However, if wind farms are to be built on a larger variety of soil types, in different water depth or with alternative types of foundations (e.g. gravity foundations) this technique may be of increasing importance. Moreover, dredging may be undertaken during preparations for barge access, cable laying routes, scour protection or removal of built up sediment after construction (cf. NEDWELL & HOWELL 2004). The noise emitted and the mechanics of sound transmission will depend on the dredging technique used, but generally involves machinery noise and sediment transportation noise (NEDWELL & HOWELL 2004).

In an assessment of the environmental impacts of the Oakland Harbour Navigation Improvement Project, the possible effects of underwater dredging activities on marine life have been summarised (ANON. 2000) and are shown in Table 9.

Table 9: Impacts that could affect marine mammals directly or indirectly during or after underwater dredging activities.

<i>Parameter</i>	<i>Possible direct effect</i>	<i>Possible indirect effect</i>	<i>Factors</i>
Acoustic disturbance	Displacement	Effect on prey abundance	Duration Noise levels Time schedule/ season
Increased turbidity (together with suspension of toxics)	Altered taste of water	Effect on prey abundance	Duration of impact depends on sediment type Extend of effect depends on currents
Physical disturbance (boat presence)	Displacement	Effect on prey abundance	Duration Time schedule/ season
Habitat alteration		Effect on prey abundance	e.g. removal of soft-bottom, addition of hard-bottom substrate

#### **NEDWELL & HOWELL (2004):**

NEDWELL & HOWELL (2004) review some findings concerning the acoustic emissions and the effects of dredging activities on marine mammals. Two suction dredgers have been found to have octave band spectral peaks between 80 and 200 Hz of up to 177 dB re 1  $\mu$ Pa (no distance given). In the 20 to 1000 Hz band, the two vessels were measured as emitting noise reaching 133 dB re 1  $\mu$ Pa at a distance of 190 m, and 140 dB re 1  $\mu$ Pa at 200 m, respectively. The sound emission of a hopper dredge, given at a 20 - 1000 Hz band level, was measured to be up to 142 and 117 dB re 1  $\mu$ Pa at distances of 930 m and 13.3 km for loading and depositing, respectively (water depth 20 m). Two other dredgers were reported to emit 138 dB re 1  $\mu$ Pa at 430 m (again 20 –1000 Hz band level, loading in 21 m water depth) and 131 dB re 1  $\mu$ Pa (same band) at 1.5 km distance, depositing in more shallow water of 12 m depth (see NEDWELL & HOWELL 2004 and literature cited therein). The authors conclude that despite the scarcity of data, it can be assumed that dredging noise is audible for cetaceans at ranges of several kilometres from the source. Based on a cylindrical spread scenario, the levels quoted would result in source levels of between 179 and 201 dB re 1  $\mu$ Pa at 1 m, which would be clearly audible for marine mammals.

#### **RICHARDSON *et al.* (1995):**

RICHARDSON *et al.* (1995) reported on a study in which the bowhead whale (*Balaena mysticetus*) showed signs of avoidance to playbacks of dredging noise as it reached levels of 20 to 30 dB above ambient noise.

#### **CALIFORNIA DEPARTMENT OF TRANSPORTATION 2003:**

During the construction of the San Francisco-Oakland Bay Bridge, some dredging was conducted. On the four days of marine mammal monitoring during dredging activities,



only a single harbour seal was observed. This animal showed no reaction to the construction noise (CALTRANS 2003).

### 10.3 Drilling

#### **NEDWELL & HOWELL 2004:**

NEDWELL & HOWELL (2004) review some results of noise measurements during underwater drilling activities. Only two relevant studies are quoted here. Shallow water measurements (water depth between 6 and 7 m) of acoustic emissions of a drill rig showed levels of 125 dB re 1  $\mu$ Pa at 130m and 86 dB re 1  $\mu$ Pa at 480 m distance. Another study revealed tonal components of drilling noise at 5, 20, 60, 150 and 450 Hz, with the dominant 5 Hz tone having a level of 119 dB re 1  $\mu$ Pa at 115 m from the drill (water depth 15 m).

#### **RICHARDSON *et al.* (1995):**

In their review of the limited observations of effects of drilling on marine mammals, RICHARDSON *et al.* (1995) conclude that cetaceans avoided drilling activities when the received levels of underwater noise were well above background levels.

### **Conclusion**

The results from the PIDP and PIDP re-strike provide only limited information on the effects of these activities on marine mammals. Only few mammals (harbour seals and California sea lions) were seen in the MMSZ, so that conclusions on effects on marine mammals are based on rather limited data.

Vibratory pile driving seems to be a promising alternative to impact hammers, due to potentially lower noise levels. However, the available data are not sufficient for any conclusion as yet. Drilling seems to involve much lower sound levels than impulsive pile driving, and this method would potentially be used in the North and Baltic Seas to install wind turbines at sites with hard substrate layers.

The reactions of large baleen whales to the effects of dredging noise cannot be transferred to small cetaceans or pinnipeds, due to their different hearing systems.

The available information on the potential effect on marine mammals is scarce. Future construction activities by any technique discussed should be used for dedicated studies on possible behavioural effects on marine mammals. Furthermore these effects could be studied within the scope of controlled exposure experiments. Any physiological effect could best be studied by conducting dedicated hearing studies on animals in a controlled situation.

## 11 Operation of Offshore Wind Turbines: Noise Emitted and Effects on Marine Mammals

The operational phase is by far the longest phase in the lifecycle of a wind farm, with an estimated, and commissioned, duration of approx. twenty years. To date, there have been only a few measurements of noise emissions from operating offshore wind turbines. More data is needed, and should be collected over the next few years. In one of its latest reports, the DEWI (2004) therefore summarised a preliminary synopsis of parameters that should be considered during such measurements. The authors suggest conducting measurements of single turbines of a wind park at defined rate of rotations and at a distance of an order of magnitude of 100 m. The full range of power output from low speed up to the maximum rotation rate (rpm) should be measured, at least at three different levels including the maximum, and the actual output should be documented over time parallel to the sound measurements. As under maximum power output conditions the sea can be expected to be rather rough, the authors suggest the use of stationary deployed units instead of ship-based measurements. Continuous recordings over time for at least 5 min per output level are recommended. The authors state that the range of frequencies should be between 5 and 20 kHz, and that the measurements should be taken at 3 to 5 m above the sea floor, but not above mid-water. For each power output level  $1/3$  octave levels over 1 min in dB re 1  $\mu$ Pa should be given for both distances, for the position of measurement and for the calculated, standardised source level distance of 1 m. In addition, the authors suggest narrow band spectra for each output level at a suitable frequency resolution. This would allow detection of tonal components which might result in levels of more than 20 dB above the average operational source level of a wind turbine. It is still unclear whether these tonal components are biologically relevant to the animals. In addition, some reports address the effects that the operational sounds of offshore wind turbines have on marine mammals. Here too, much more research is needed and to be expected in the years to come.

### 11.1 Noise Measurements

#### DEGN 2000:

Ødegaard and Danneskiold-Samsø conducted sound measurements of underwater noise emitted by offshore wind turbines at Vindeby, Denmark, and Gotland, Sweden, in January and February 2000 on behalf of SEAS (DEGN 2000). While the turbine at Vindeby (450 kW) has a concrete gravitational foundation, the foundation at Gotland (550 kW) is of the monopile type. The two types were chosen to assess possible differences in noise emission dependent on foundation type. In both cases, noise measurements were taken while only the observed turbine was operating in the park. In addition to noise recordings, vibration at the turbine foundation was measured as a basis for future estimates of sound emissions of larger (2 MW) turbines.

Noise measurements at Vindeby were taken at a distance of 14 m, at 1.2 m depth. in 2.5 m deep water., by hydrophone. The wind speed during the recording was 13 m/s. During turbine operation, the highest noise level of nearly 120 dB re 1  $\mu$ Pa (at 14 m) was reached at between 20 and 30 Hz (see Fig. 10). At frequencies above 400 Hz and up to 20 kHz, the operational noise was less than 3 dB above the background level. This difference is within the uncertainty range of the measurements.

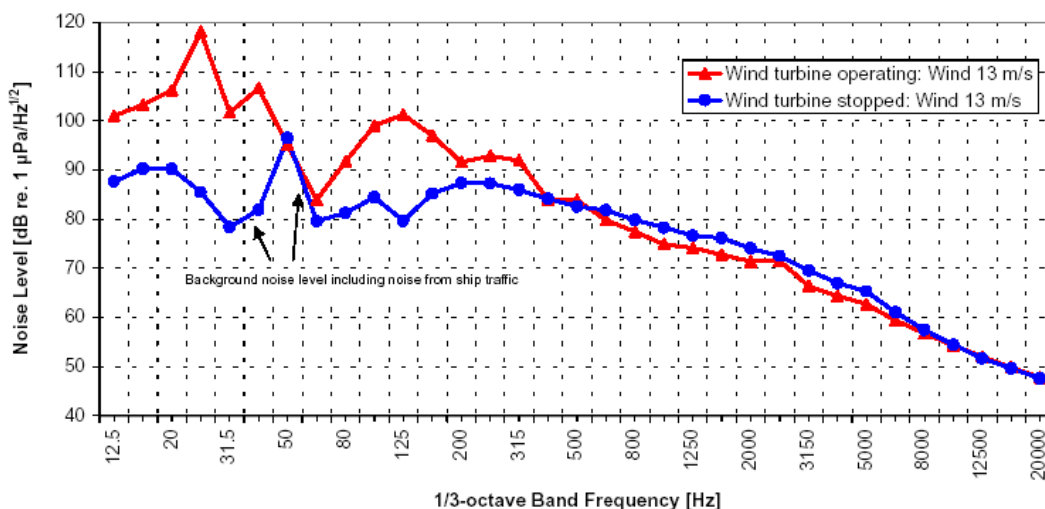

Fig.10: Underwater noise emitted from a single offshore turbine (450 kW) at Vindeby and respective background noise. Levels are recorded at a distance of 14 m from the turbine and are plotted in  $\frac{1}{3}$  octave bands with linear averaging over 4 to 5 minutes (from: DEGN 2000).

At frequencies between 20 and 100 kHz, no significant difference in noise levels between operating and stopped wind turbine measurements was found (values below 45 dB re 1  $\mu$ Pa).

For calculations of the source level (1 m distance), the author gives an estimate of 11.5 dB to be added to the noise levels registered at 14 m, resulting in a maximum level of 131.5 dB re 1  $\mu$ Pa at 1 m for the Vindeby turbine.

At Gotland, sound recordings were taken at a distance of 20 m from the only operating turbine at 2 m depth in 4 m deep water, by hydrophone. The wind speed was 8 m/s. The operating turbine reached maximum noise levels of approx. 95 dB re 1  $\mu$ Pa (at 20 m distance) at approx. 15 and 160 Hz. While the maximum at 15 Hz was not significantly above the background level the peak at 160 Hz was about 25 dB about the level registered when the turbine was stopped (see Fig. 11).

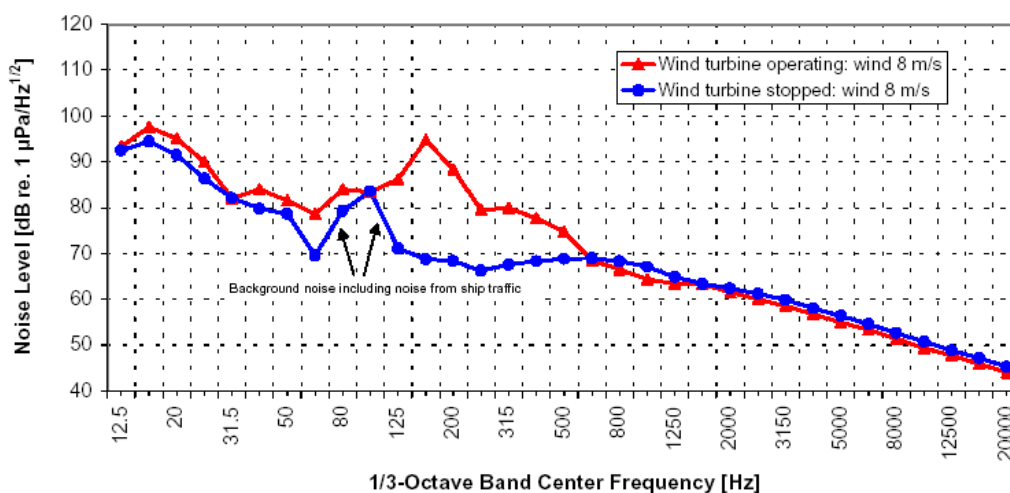

Fig. 11: Underwater noise emitted from a single offshore turbine (550 kW) at Gotland and respective background noise. Levels are recorded at a distance of 20 m from the turbine and are plotted in  $\frac{1}{3}$  octave bands with linear averaging over 4 to 5 minutes (from: DEGN 2000).

At Gotland, as for the turbine at Vindeby, for frequencies between 20 and 100 Hz the operating noise again caused no significant increase of the noise level defined as background when the turbine was stopped (values below 40 dB re 1  $\mu$ Pa).

For calculations of the source level (1 m distance), the author gives an estimate of 13 dB to be added to the noise levels registered at 20 m, resulting in a maximum level of 115 dB re 1  $\mu$ Pa at 1 m for the Gotland turbine.

Based on measurements of vibrations taken (i) at the Vindeby and Gotland offshore turbines as well as (ii) from a onshore 2 MW turbine, the author estimates the noise emissions of a hypothetical offshore wind turbine of the 2 MW class (Fig. 12). The concrete foundation type emits higher noise levels than the monopile turbine below 50 Hz (max. 125 dB re 1  $\mu$ Pa/Hz<sup>1/2</sup> at 20 m and 113 dB re 1  $\mu$ Pa/Hz<sup>1/2</sup> at 20 m, respectively). At frequencies between 50 and 500 Hz, however, the monopile turbine is assessed as louder than the concrete foundation wind turbine (up to 100 dB re 1  $\mu$ Pa/Hz<sup>1/2</sup> at 20 m and 90 dB re 1  $\mu$ Pa/Hz<sup>1/2</sup> at 20 m).

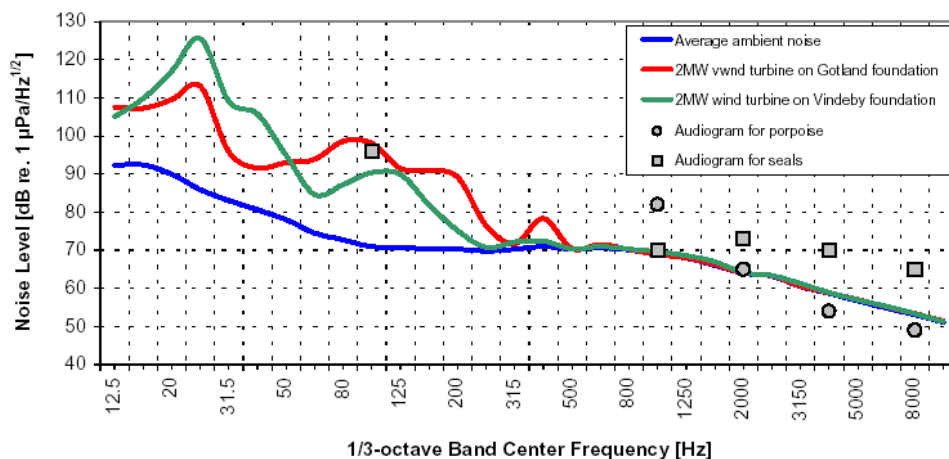

Fig. 12: Estimated underwater noise level of a hypothetical 2 MW offshore wind turbine at a distance of 20 m and a wind speed of 8 m/s, with a concrete foundation (green line), and as a steel monopile (red line). See text for calculation basis. Average hearing thresholds, taken from RICHARDSON *et al.* (1995), are given as grey marks for comparison (from: DEGN 2000).

It is noted that a future 2 MW turbine could emit higher noise levels than the 450 to 550 MW models at frequencies below 100 Hz, but is assumed that it would be less noisy than the smaller turbines at frequencies higher than 100 Hz.

The author assumes an uncertainty of 6 to 10 dB concerning the values quoted for the 2 MW turbine, due to the sub-optimal database of the calculations, and suggests further studies. He states that the difference between the foundation types in general may neither be systematic nor transferable to other wind farms, but could rather be dependent on the dimension and construction of each specific foundation.

### FRISTED *et al.* 2001:

In their report FRISTED *et al.* (2001) documented the results of a hydroacoustic measurement conducted in August 2000 at the offshore wind farm at Bockstigen, Sweden. The recordings, being part of a pilot study, were performed under low wind conditions only, and no representative background noise measurements were undertaken. The wind turbine No.1 under consideration is built on a monopile

foundation in a water depth of 6 m and is one of five turbines of the 500 kW class in this wind farm. Four hydrophones were placed at distances of 50, 200, 400 and 1000 m from the wind turbine, in a line with increasing water depth from 6 to 17 m. All four devices were deployed 2 m above the sea bottom, which consists of gravel on limestone in this area. Additional data were recorded for calculations of transmission loss, the results are not presented in this pilot study, but are available for future modelling. The sound recordings were conducted at wind speeds around 5 m/s, which produces only minimum power output. The resulting spectrum shows peaks at frequencies between 100 and 400 Hz, reaching a maximum of 111 dB re 1  $\mu$ Pa at a distance of 50 m (Fig. 13).

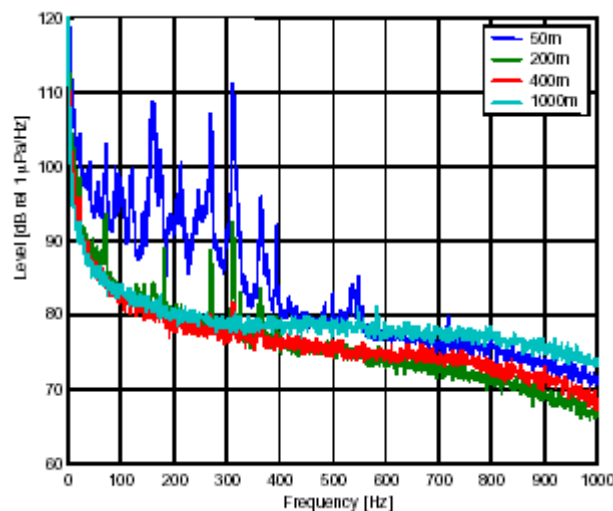

Fig. 13: Spectrum of noise levels at the four different distances of hydroacoustic measurements performed at Bockstigen No. 1 during operation. The wind speed was 4 to 5 m/s. (from: FRISTED *et al.* 2001).

During the measurement of background noise, only Bockstigen No. 1 was switched off while the other wind turbines of the park continued to rotate (the closest being 400 m away from No.1). Due to the uncertain effect of these turbines, no well-grounded statement on the background noise level can be made.

Due to the pilot study nature of this investigation, the amount and the applicability of the results were limited.

### INGEMANSSON TECHNOLOGY 2003:

Measurements of operational noise from an offshore wind turbine were conducted by INGEMANSSON TECHNOLOGY (2003) at the wind farm of Utgrunden, Sweden. This park consists of seven 1.5 MW turbines, built in water depths of between 4 and 10 m. A complex design of the measurements was set up to ensure optimal relevance of the results concerning sound propagation as well as the effect of various wind speeds. Not all intentions of the investigation schedule were fully met; nonetheless, the long period of measurements between November 2002 and February 2003 yielded extensive information.

Three hydrophones were placed 1 m above the sea floor at various distances from turbine No. 4 (Fig. 14 and Table 10).

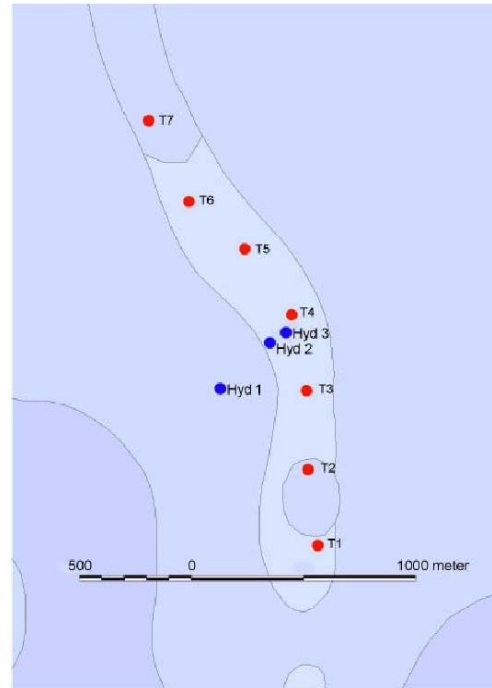

Fig. 14: Locations of the seven 1.5 MW turbines and three hydrophones at Utgrunden wind farm (from: INGEMANSSON TECHNOLOGY 2003).

Table 10: The three hydrophones deployed at Utgrunden: distances to turbine 4 and water depths (after: INGEMANSSON TECHNOLOGY 2003) .

<i>Hydrophone</i>	<i>Distance to turbine 4</i>	<i>Water depth</i>
Hyd 1	463 m	18.0 m
Hyd 2	160 m	15.2 m
Hyd 3	83 m	12.9 m

The frequencies recorded were between 1 and 2000 Hz. Narrow band spectrums are calculated with a resolution of 1 Hz and the spectrums are averaged over the entire available time period for the respective measurement, at least three minutes.

At high wind speed conditions (11 to 14 m/s) and a generator speed of approx. 1780 rpm, the noise emissions of the single turbine at a distance of 83 m was characterised by peaks at frequencies of 31 Hz (approx. 106 dB re 1  $\mu$ Pa), 61 Hz (approx. 107 dB re 1  $\mu$ Pa), 178 Hz (approx. 125 dB re 1  $\mu$ Pa), 359 Hz (approx. 98 dB re 1  $\mu$ Pa), 538 Hz (approx. 96 dB re 1  $\mu$ Pa) and 722 Hz (approx. 101 dB re 1  $\mu$ Pa) (see Fig. 15).

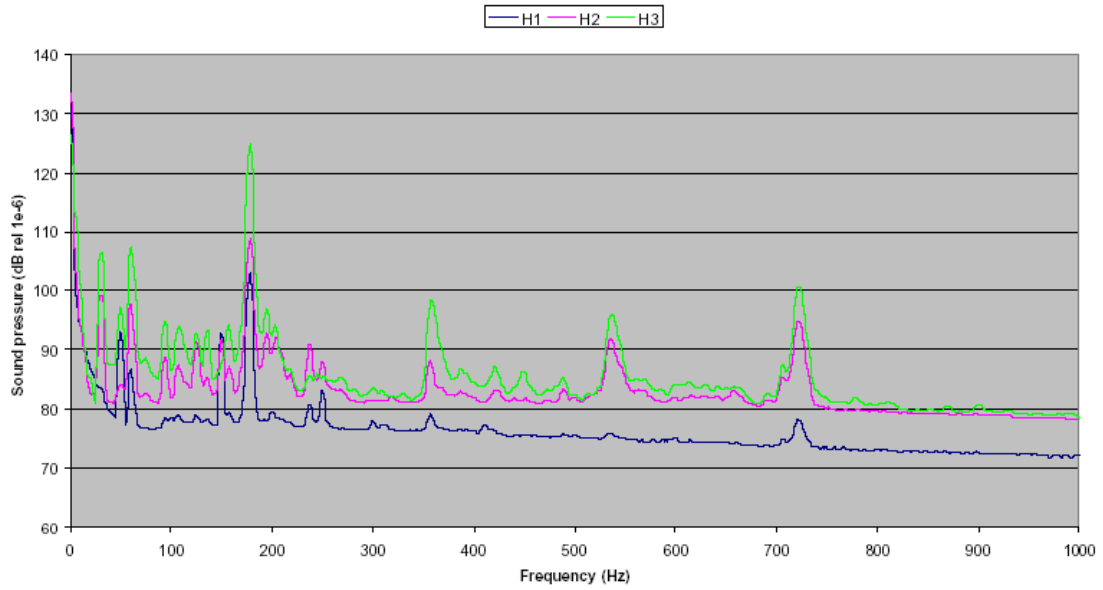

Fig. 15: Sound measured at turbine 4 at high wind conditions (11 to 14 m/s, east) plotted for the different hydrophone positions 463 m, 160 m and 83 m distance (from: INGEMANSSON TECHNOLOGY 2003).

In the frequency range between 1000 and 2000 Hz a general low level of sound emissions was recorded (below 80 dB re 1  $\mu$ Pa), with only one small peak at approx. 1930 Hz with 83 dB re 1  $\mu$ Pa at 83 m, which was not addressed further. The attenuation values listed in Table 11 were calculated from the data on sound levels decreasing with distance.

Table 11: Attenuation per doubled distance at different frequencies and hydrophone locations (after: INGEMANSSON TECHNOLOGY AB 2003).

Frequency (Hz)	Attenuation per doubled distance (dB)		
	Hyd 3 – Hyd 2	Hyd 3 – Hyd 1	Hyd 2 – Hyd 1
30.5	3.5	4.1	5.4
61.0	4.8	3.7	3.8
178.2	7.9	3.9	2.1
357.7	5.1	3.4	3.1
537.1	2.2	3.6	5.4
722.7	3.0	4.1	5.8
<b>Average</b>	<b>4.4</b>	<b>3.8</b>	<b>4.3</b>

The average attenuation per doubled distance in the considered frequency range is approx. 4 dB, with no clear dependence on frequency.

The authors found that with increasing wind speed, the sound pressure level increased and the dominating frequencies moved towards higher values (Fig. 16).

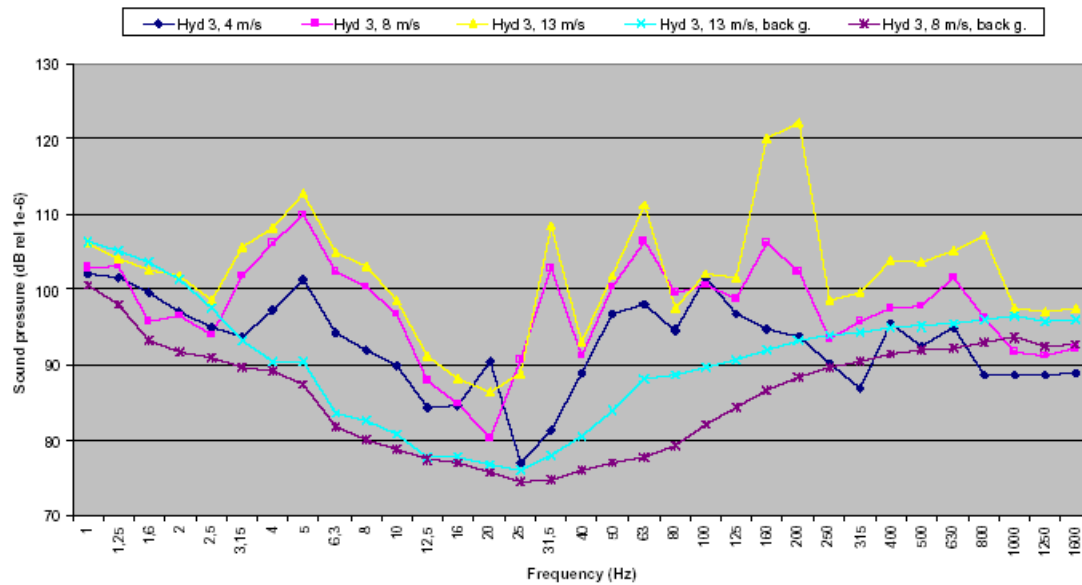

Fig. 16: Received sound levels ( $1/3$  octave plot) recorded at hydrophone location 3 (83 m distance to wind turbine) at different wind speeds of 4, 8 and 14 m/s (from: INGEMANSSON TECHNOLOGY AB 2003).

As part of their extensive investigation INGEMANSSON TECHNOLOGY AB (2003) also conducted sound recordings during a sequential shut down of the seven wind turbines. This procedure gradually lowered the total level of emitted sound. The strongest decrease occurred when the closest turbine, no. 4, was off. The authors reported that no clear tendency of interference of the noise of the different turbines could be observed.

These authors are among the few to give a reason for the frequency range of 1 to 2000 Hz used, stating that below 1 Hz, the very high sound pressure levels of waves causes dynamic measurement problems. Also, the sound levels emitted by offshore wind turbines below 1 Hz are very low. The upper limit of 2000 Hz is explained by the lack of importance of higher frequencies for fish, as they cannot hear above this frequency. Marine mammals are not considered in this context.

#### **BETKE *et al.* 2003, BETKE *et al.* 2004, ZIELKE *et al.* 2004, DEWI *et al.* 2004:**

The reports by BETKE *et al.* (2003 and 2004), ZIELKE *et al.* (2004) and DEWI *et al.* (2004) refer to the same measurements conducted at the offshore wind farm of Utgrunden, Sweden and on an onshore 4.5 MW wind turbine. Of the seven 1.5 MW turbines of the Utgrunden park, only the middle turbine (no. 4) was operating during the sound recordings (the same turbine measured in INGEMANSSON TECHNOLOGY AB 2003, but different data sets). Background noise was measured when all turbines were off. One hydrophone was deployed 110 m from the monopile foundation of the turbine 3 m above the sea floor which is at a depth of 10 m at this site. Sound level was measured between 2 Hz and 2 kHz. The wind speed varied between 3.5 and 17 m/s and power output was between 80 and 1500 kW during the recordings.

Both background noise and operational turbine noise had peaks at low frequencies around 2 Hz (background approx. 108 dB re 1  $\mu$ Pa, operation max. power output approx. 114 dB re 1  $\mu$ Pa at 110 m in a  $1/3$  octave spectrum graph; Fig. 17).



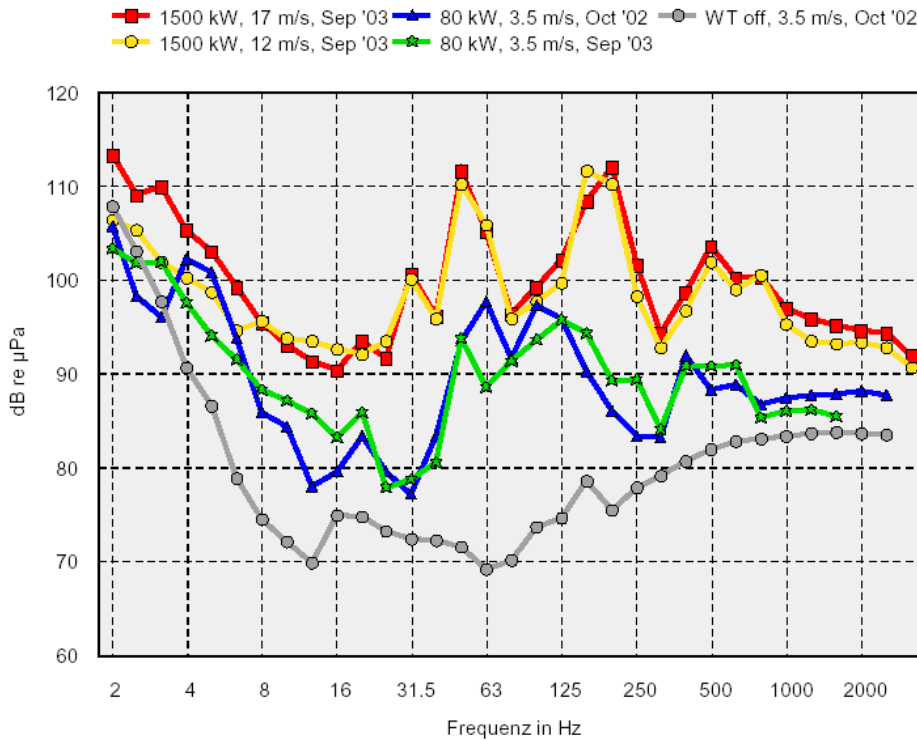

Fig. 17: Underwater sound emitted from a 1.5 MW offshore turbine at Utgrunden, Sweden, at various wind speeds ( $1/3$  octave band spectrum). Only one turbine was operating during measurement. At background noise recording, no turbines were running (from: DEWI 2004).

The sound pressure spectrum of a hypothetical 4.5 MW offshore wind turbine at a distance of 10 m was estimated using a numeric model based on the measurement of forces and vibrations of an onshore 4.5 MW wind turbine (Fig. 18). The pressure peaks of approx. 9 and 10 Pa are predicted at 130 and 200 Hz. The calculated level is 149 dB re 1  $\mu$ Pa at 10 m.

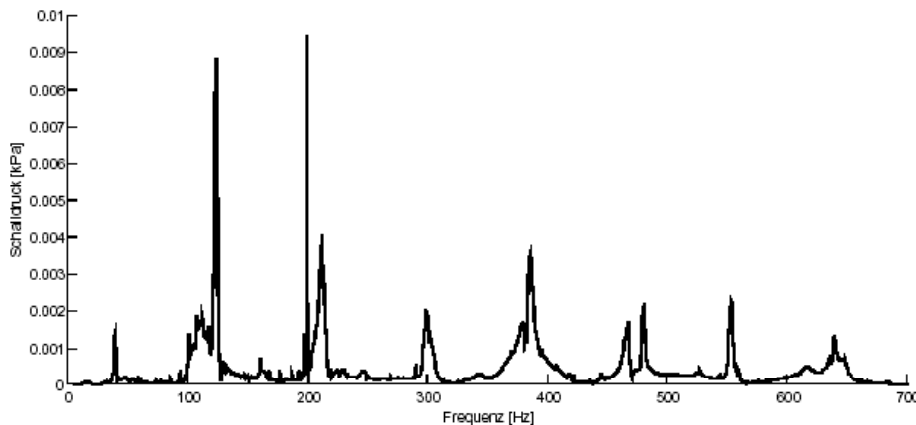

Fig. 18: Spectrum of sound pressure emitted from a hypothetical 4.5 MW offshore wind turbine during operation at a distance of 10 m, estimated using a numeric model and averaged over the water depth (from: DEWI 2004).

The authors present an alternative, simpler empirical model to estimate the underwater noise emitted from a future offshore wind turbine of the 4 to 5 MW class. It is based on vibrations measured at an onshore wind turbine and the noise emissions of an existing smaller offshore model. In the frequency range of 16 to 1000 Hz, a single 2.5 MW offshore turbine would emit underwater noise of source levels between 110 dB re 1  $\mu$ Pa

at 1 m (at 1000 Hz) and 160 dB re 1  $\mu$ Pa at 1 m (125 Hz). The model is used to estimate the noise emitted from an entire wind farm of seventy turbines with a maximum output of 1.5 MW each. The model indicates that the noise level emitted from such a wind farm would reach 108 dB re 1  $\mu$ Pa at a distance of approx. 1.3 km from the outer line of turbines for the octave band of 250 Hz. At 63 Hz, the sound level would be approx. 109 dB re 1  $\mu$ Pa at the same distance.

The authors emphasise the lack of data on the lower frequency hearing thresholds for the marine mammal species in German waters and on the tonal elements in the spectra of sounds emitted from operating wind turbines; they also stress the need for further studies on the transmission of sound underwater. These parameters are vital for the assessment of the spatial extent of the impact zones of wind turbine noise.

## 11.2 Effects on Marine Mammals

The reports reviewed in the following section focus mainly on the effects of wind farm noise on marine mammals, but also include some results of sound level measurements similar to the ones presented in the previous chapter.

### **KOSCHINSKI *et al.* 2003:**

The sound recorded at an operating offshore wind turbine of the 550 kW class in Sweden at a distance of 20 m was modified by KOSCHINSKI *et al.* (2003) to simulate the noise of a 2 MW wind turbine. The resulting sound was transmitted underwater to free-ranging harbour porpoises and harbour seals off Vancouver Island, Canada. The played-back sound had a maximum sound level of 128 dB re 1  $\mu$ Pa (source level at 1 m), which is reached at the  $1/3$  octave band centre frequencies of 80 and 160 Hz. Swimming, surfacing and echolocation behaviour of the observed mammals was recorded. During sound exposure, the harbour seals apparently moved slightly away from the sound source, surfacing at a median distance of 284 m, instead of 239 m for controls. Harbour porpoises were observed keeping a distance of 182 m or more from the transducer, while at controls (transducer switched off), they approached to 120 m. The echolocation rate of harbour porpoise increased during noise exposure.

Some critical questions of whether the sound amplifying method met the conditions of a 2 MW turbine were discussed by MADSEN *et al.* (in press). They conclude that it is likely that the procedure used by KOSCHINSKI *et al.* included high frequency artefacts, which were amplified and transmitted along with the simulated operational sound of the wind turbines, and would have been audible to the marine mammals over greater distances than the wind turbine signals. Thus the actual impact range for wind turbine related sounds might actually be smaller than this study suggests.

### **Sweden**

#### **SUNDBERG & SÖDERMAN 1999:**

In the study published by SUNDBERG & SÖDERMAN (1999, see also Chapter 9.2) the authors present results obtained during the operation of the five wind turbines at Bockstigen wind farm since the beginning of the operational phase from the spring of 1998 to June 1999. The steel monopile foundations are situated in 7 m deep water. Parallel to the counts of grey seals at the two adjacent haul-out sites, the number of rotating turbines was registered in classes from 0 to 4 (on only one of the days of

observation, all five turbines were operating). The authors state that no correlation between differences in seal numbers and the five classes of disturbance could be found. Local movements of the animals to other haul-out sites may be the cause for observed variations in haul-out numbers. It is emphasised that e.g. harbour seals have been reported to adapt very well to such newly built structures as bridges. No measurements of sound emissions of the wind farm have been conducted.

## Denmark (and Sweden)

### HENRIKSEN *et al.* 2001:

In their poster at the 14th Biennial Conference on the Biology of Marine Mammals HENRIKSEN *et al.* (2001) estimated the ability of harbour seals and grey seals to detect the underwater noise of offshore wind turbines. They reviewed measurements of operational sound at three different offshore wind turbines with maximum power outputs of 450 kW (concrete gravitational foundation), 550 kW (steel monopile foundation) and 2 MW (concrete gravitational foundation), recorded in a frequency range of 12 to 500 Hz. Worst-case audiograms (i.e. lowest plausible estimates for hearing thresholds) for harbour porpoises and harbour seals were assessed based on previous findings on a wide range of marine mammal species. Due to the lack of data on grey seals, this species was assumed to have the same hearing abilities as harbour seals. Before comparison of hearing thresholds with the source sound levels of wind turbines, the latter were converted from dB re 1  $\mu\text{Pa}^2/\text{Hz}$  to dB re 1  $\mu\text{Pa}/(1/3 \text{ octave})$  units to consider the characteristics of masking in marine mammal hearing (HENRIKSEN *et al.* 2001 citing FLETCHER 1940). The 450 kW turbine on a concrete foundation was shown to emit higher noise levels than the monopile 550 kW wind turbine throughout the recorded frequency range (Fig. 19). The maximum source level was approx. 137 dB re 1  $\mu\text{Pa}/(1/3 \text{ octave})$  at 25 Hz. The largest turbine (2 MW) produced intermediate sound levels and was characterised by a shift towards higher frequencies (maximum level of 130 dB re 1  $\mu\text{Pa}/(1/3 \text{ octave})$  reached at 125 Hz).

The authors conclude that the turbine operational noise exceeds the hearing threshold of the harbour porpoise by a maximum value of 17 dB at a frequency of 315 Hz, leading to a range of audibility of 50 m under the assumption of cylindrical sound spread and an attenuation of 3 dB per distance doubling. This area of detection is considered to be small, thus leading to no serious effect.

Under the same hydroacoustic assumptions, it is estimated that the range of audibility for the two seal species is approx. 1000 m, as at a frequency of 125 Hz the emitted operational noise is 30 dB above the worst-case hearing threshold. The significance of this greater detection range is to be investigated further.

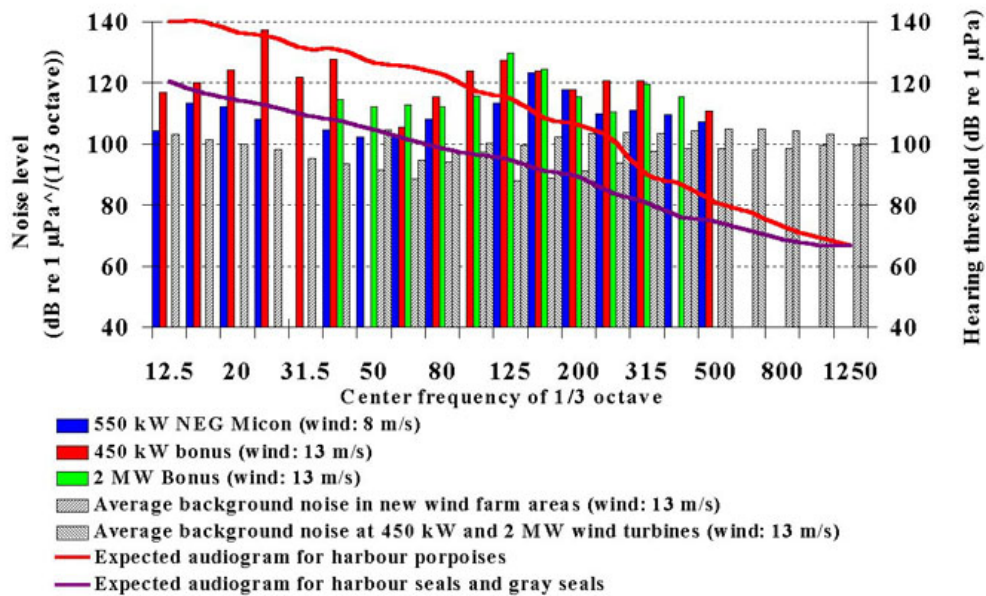

Fig. 19: Source sound levels of offshore wind turbines (coloured bars) and background noise levels (grey bars) converted for direct comparability to worst-case audiograms (see text) of harbour porpoise and seals (lines) (from: HENRIKSEN *et al.* 2001).

#### TOUGAARD & TEILMAN 2004:

Some preliminary results on harbour porpoise echolocation activity obtained through stationary POD deployments during the operational phase of the Nysted offshore wind farm are presented by TOUGAARD & TEILMAN (2004). Operation of the seventy-two turbines (2.3 MW each) began in early December 2003. The ongoing study will be conducted through 2004 and 2005 to assess long-term changes of harbour porpoise abundance in the wind farm area during the operational phase. PODs were installed within the wind farm itself (three stations) as well as in a reference area east of the park (three stations). Initial inspection of the raw data showed presence of harbour porpoises at all six stations throughout the reporting period (January through July 2004). Encounter frequencies were lower than during the baseline study, and waiting time between encounters was intermediate compared to baseline conditions (lowest waiting time) and construction phase (longest waiting time). First, statistically not fully analysed results therefore indicate that during the first months of operation of the Nysted wind farm, fewer harbour porpoises were present in the area than before construction work.

More exact results are expected to be presented in the upcoming annual reports of the complete data sets from 2004 and 2005.

#### TEILMAN *et al.* (2004b):

As the previously quoted report also this short publication on harbour seals at Rødsand by TEILMAN *et al.* (2004b) presents only scanty and preliminary results obtained in the first few months of operation of the Nysted wind farm. Aerial surveys of the adjacent haul-out sites (Rødsand and Vitten/Skrollen) revealed that the seals moved between haul-out sites, probably depending on seasonal changes in e.g. prey abundance, but no obvious negative effect from the operating wind turbines could be observed. More exact results are expected to be presented in the upcoming annual reports of the complete data sets from 2004 and 2005.

**TOUGAARD *et al.* (2004A), ELSAM ENGINEERING (2004):**

In the reports presenting results from the Danish offshore wind farm at Horns Rev (TOUGAARD *et al.* 2003A, ELSAM ENGINEERING 2004), the authors refer to a phase designated as the “post-construction period”. Although the noise-intense construction activities such as ramming etc. had ceased and power production of the wind farm was expected to start, the authors did not consider 2003 as part of the normal operational phase. They noted a high level of service and maintenance activities, with a corresponding high rate of boat travel due to technical problems of unforeseen extent. The observations made in the course of this study are therefore presented in Chapter 13, elucidating the effects of boat noise on harbour porpoises.

However, the boat traffic due to the increased maintenance activities at the Horns Rev wind farm increased starting in July. The first half of 2003 with a low number of boat passages in the wind farm area could therefore be considered as operational phase and sighting data e.g. (with comparatively low number of sightings and porpoise density respectively) could be re-analysed in this respect.

**Conclusion**

The direct behavioural responses of marine mammals to the operational noise of offshore wind turbines have not been documented to date. Most studies are designed to assess the overall effects of offshore wind turbines on marine mammals, but do not focus on the effects of the acoustic emissions of the turbines during their operational phase. The available data as reviewed by MADSEN *et al.* (in press) are sparse. They present a comprehensive discussion of the effects of operational noise on harbour seals, harbour porpoises and two other cetacean species as documented to date. They conclude that behavioural effects on the marine mammals, if any, are likely to be minor, and to occur close to the turbines. Based on the results of KOSCHINSKI *et al.* (2003), as discussed in detail in MADSEN *et al.*, it is likely that the range of behavioural responses of harbour porpoises and harbour seals around wind turbines due to operational noise will be small. Given the critical consideration stated above, the resulting impact zone for both porpoises and seals might even be smaller, as measured by KOSCHINSKI *et al.* (2003). However, all data to date on the behavioural reactions of marine mammals refer to wind turbines of up to 2 MW. Given that in the near future, wind turbines of up to 5 MW are to be installed offshore, the resulting operational noise could be significantly different, and therefore any assessment on resulting behavioural effects must be treated with reservation.

## 12 Removal of Offshore Wind Farms and Other Structures after Decommissioning: Noise Emitted and Effects on Marine Mammals

The permit to install offshore wind turbines in the German EEZ includes the requirement to remove the turbines at the end of their life-span. The permit is initially limited to twenty-five years, but can be extended. Financial guarantees to cover the costs of decommissioning are required before a permit to build a wind farm will be issued by the BSH. However, the method for decommissioning is neither specified nor mentioned in any of the available relevant documents. As no prior experience is possible with regard to offshore wind turbines, information on the methods and experience with the removal of comparable structures will be presented.

### *Explosive Removal:*

A review by the CONTINENTAL SHELF ASSOCIATES, INC. (2004) summarises the effect of a shock wave caused by an underwater explosion. Especially gas-containing organs such as the lungs and trachea, the gastrointestinal tract, the nasal sacs etc. are susceptible to damage, as physical disruption occurs at boundaries between tissues of different density. Two recent studies exposed dead marine mammals to the shock waves of underwater explosions (KETTEN *et al.* 2003 and REIDENBERG & LAITMAN 2003, both cited in CONTINENTAL SHELF ASSOCIATES, INC 2004). Destruction of tissue was found not only in the gas-containing organs, but also in the melon, at the blubber-muscle boundaries and the jaw fats. The effects were assumed to be consistent with those on a live animal. The ears of marine mammals, as pressure-sensitive organs, suffer the greatest damage from pressure shocks (KETTEN 2000).

The permit from NMFS for the explosive removal of oil and gas structures in the Gulf of Mexico required the presence of NMFS-approved observers before, during and after detonation, and aerial surveys of at least 30 min duration within one hour of the detonation episode in an area of 1 nmi around the structure, to ensure that no marine mammals were within the 941 m safety zone, nor were likely to enter it at the time of detonation (DZWILEWSKI & FENTON 2003).

It can be assumed that in terms of the general effect on marine mammals, the explosive removal of offshore wind turbines is comparable to the construction phase. Both activities are accompanied by the emission of impulsive sound.

### *Water-Jet Cutting:*

This method is already in use for the removal of jacket platforms. A high power water jet is generated which cuts steel of up to several centimetres thickness. To date, it has been used to cut tubulars of from 6 to 84 inches in diameter. The operators claim that this method is environmentally safe, economical and fast (ANON 1999). Furthermore, they state that unlike explosive cutting, water-jet cutting requires no special permits, no airborne observers, and marine mammals need not be kept away ([www.oilstates.com/solutions/offshore/decommissioning/abrasive%20cutting/file.asp](http://www.oilstates.com/solutions/offshore/decommissioning/abrasive%20cutting/file.asp)). Cutting can proceed as needed, even at night. Water-jet cutting related noise emissions have so far only been measured in air (HUTT 2004). The frequency and sound pressure level of the emission is correlated with the water pressure used, the nozzle diameter, its

angle and the stand-off distance to the material to be cut. The main energy is concentrated in a frequency band between 4-8 kHz and reaches values up to 117 dB(A).

## Conclusion

While the effect of water-jet cutting on marine mammals cannot be assessed, it is clear that the use of explosives to remove the wind turbines would be audible over great distances and would be very likely to cause severe injuries or impairment to marine mammals at close range if used with no precautionary measures. The available techniques must be studied in greater detail with regard to safety zones and potential mitigation measures, and alternative methods should be developed and tested.

## 13 Boat Noise and Effects on Marine Mammals

To date, observations of the effect of wind farm related boat traffic itself is scarce, but the noise produced by ships and the effect of vessel density in general on marine mammals has been addressed by a number of studies in fields not directly related to offshore turbine deployment, the results of which are reviewed later in this chapter.

Site investigation activities at potential wind farms are mainly ship-based (see Chapter 8). During both the construction and the operational phases of the wind farm, boats of various sizes will be commuting between the shore and the wind farm site, first to transport the parts, the equipment and personnel needed for construction, later for inspection and maintenance. Any type of removal – be it by explosive or abrasive methods (see Chapter 12) – will also require the transportation of equipment and personnel, the presence of a working platform and the transportation of the recovered material. Finally, additional boat presence will be necessary for the observers conducting the environmental surveys.

A recent online review (OFFSHOREWINDENERGY 2004) states that service visits to the offshore wind turbines are conducted regularly about every six months from the second year of operation on, with the time expenditure being on the order of magnitude of forty to eighty worker-hours, for the present generation of offshore wind turbines. The first operational year is usually more demanding, and a major overhaul will also be undertaken every five years, requiring some 100 worker-hours.

Experience from Tunø Knob (Danish Baltic Sea, constructed 1995) show that the total number of service visits have been about 35 to 70 visits per year, an average of approximately 5 visits for each of the 10 turbines per annum. A 32 foot (9.75 m) fibreglass boat, equipped with a 185 hp diesel engine, is used for the service rounds (cf. OFFSHOREWINDENERGY 2004).

In contrast to the impulse-like sounds of the investigation, construction and dismantling processes described in the previous chapters, boat noise has a continuous character. Whether or not this continuity is perceived by an individual marine mammal depends on how long the “acoustic encounter” between the animal and the ship lasts, and on the time elapsing between single encounters of the same type (e.g. frequent ship passages along main routes, or rare contact). Due to its tendency to be continuous, the aspect of displacement is important in this context.

In addition to the engine and the water flow over the hull, the propeller of a ship is a primary source of boat noise, with the sound of cavitation accounting for 80 to 85% of the sound power radiated by the vessel (cf. HILDEBRAND 2004 and literature cited therein). Cavitation occurs when bubbles form within an area of reduced pressure in the water, caused by the propeller action. The collapse, or implosion, of these bubbles generates sound that may include tonal components as well as broadband noise. The dominant emitted frequency tends to decrease with increasing ship size (RICHARDSON *et al.* 1995).

According to the list of ships used to conduct offshore wind farm related works under the flags of European countries (OILFIELD PUBLICATIONS 2003), the sizes of vessels range from 8 to 73,887 GRT and 11 to 217 m length (under the German flag: 165 to 17,500 GRT and 27.3 to 165.9 m length); they are equipped with machines of between 99 and 114,432 hp (under the German flag: 784 to 10,872 hp).

#### **SUNDBERG & SÖDERMAN (1999):**

At the grey seal haul-out sites Killingholm and Näsrevet (off Gotland), the authors found that the animals reacted to active wind farm related boat traffic by leaving the haul-out site only for a short time (SUNDBERG & SÖDERMAN 1999). Boats at stand-still were tolerated by the grey seals, so that the commuting rate seems to be the crucial factor in evaluating the disturbance. The authors recommend restriction of traffic during the moult of the grey seals, i.e. during May and early June. The possibility of deviations of wind farm related boat traffic routes to another harbour, thus avoiding close passages of the haul-out sites, is considered.

#### **DAVID (2002):**

In her report to ACCOBAMS on the influence of ship traffic on Mediterranean cetaceans, DAVID (2002) states that coastal species are more likely to be exposed to intensive boat traffic on a regular basis, and may therefore be more accustomed to this kind of encounter. However, the vulnerability of the affected individual towards the disturbance may be different depending on such factors as (i) commitment to an essential activity (e.g. feeding or breeding), (ii) social bonds within a group (e.g. mother to calf), (iii) age of the animal (inexperienced or experienced), (iv) sex and (v) character. The author differentiates positive reactions (approach towards the boat), indifference (no apparent disturbance) and negative reactions (e.g. avoidance) to boat passages; however, harbour porpoises are described as usually responding negatively to all kinds of vessels. In the literature reviewed by the author, the effect of ships changing direction and speed is seen as more critical than that of vessels passing in a steady manner. DAVID (2002) also mentions the possibility of indirect negative consequences through mechanical disturbance of the seafloor, i.e. increased turbidity and altered prey density. The author concludes that the presence of boats can cause physical harm (e.g. deafness), displacement, disruption of social, feeding and resting behaviour and thus can have long-term effects up to the population level. Although where the possibility of habituation is given, the author warns that experience from one study site might not be applicable for another. The author urges that the following precautionary steps be taken: (i) a study of the distribution of animals in space and time, (ii) development of predictive models of distribution, (iii) definition of sensitive areas, (iv) determination of the characteristics of the boat traffic, and of the short and long-term effects of different boat types on marine mammals, (v) development of effective deterrence methods, (vi) development of laws and regulations on sensitive areas, and (vii) education of captains and company directors.



**BIRKUN (2002):**

In a report to ACCOBAMS, BIRKUN (2002) considers the effect of marine traffic in the Black Sea on the population of harbour porpoises. The author states that the movements of this species, including that between the Mediterranean and the Black Sea through the Strait of Bosphorus, shows a decrease over the years which might be due to the high level of ship activities forming a barrier (see BIRKUN 2002 and literature cited therein).

**EVANS (2003):**

The sound level of motor-powered ships generally increases with ship size, speed and (at least at low frequencies) with the power of the engine. As reviewed in a report to ASCOBANS, smaller tankers and freighters (lengths of approx. 135 m) emit sounds around 170 dB (source level) at frequencies between 40 and 400 Hz, while fishing trawlers of approx. 30 m length produce sound source levels of 158 dB within a frequency range of 100 to 250 Hz (see EVANS 2003 and literature cited therein). The rotation of a ship's propeller blade may cause tonal components of up to 100 Hz and resonant characteristics between 100 Hz and 1 kHz. Additionally, broadband components extending to up to 100 kHz are caused by the water flow along the hull and by propeller cavitation, which is increased by high travel speed and by damage to the propeller. Therefore, these factors extend the typical range of frequencies generated from marine traffic from components below 1 kHz to the sector of higher frequencies. Small boats of up to 15 m length with a 240 hp engine were found to produce source levels of 100-125 dB re 1  $\mu$ Pa at 2 kHz and 60-105 dB re 1  $\mu$ Pa at 20 kHz (see EVANS 2003 and literature cited therein). The author, along with the cited sources, concludes that (i) vessels used should be designed to be as silent as possible, although the increased risk of ship strikes should also be taken into account, (ii) knowledge of the seasonality and diurnal pattern of indigenous marine mammals should be used to time vessel activities in order to mitigate interference, (iii) corridors of traffic should be situated away from main concentrations of animals (e.g. seal haul-out sites), and (iv) vessel speed should be kept low; however, effects of increased passage time must be considered.

**EDREN *et al.* (2004a):**

Concerning the harbour seals hauled out on Rødsand, EDRÉN *et al.* (2004a) report that there was no change in boat-induced disturbance rate during the construction of the Nysted offshore wind farm. The authors attributed this to the fact that there was a regulation in force advising boats to pass the sanctuary at an adequate distance. Apparently, the intensification of the previously experienced factor of distant boat traffic did not affect the number of seals on land.

**TOUGAARD *et al.* (2004):**

The authors suggest that the importance of sound immission to harbour porpoises caused by service ship traffic must be seen in relation to the long-term, non-wind-farm related level of boat noise in the area considered. In the described case of the Horns Rev wind farm, unforeseen technical difficulties with the turbines during the operational phase led, mainly in the second half of 2003, to a frequency of shipping activities that was much higher than expected. The peak of activities was between mid-July and mid-September, when the analysed service boat actively operated for 10-12 hrs daily. There were up to five maintenance vessels active at a time, leading to ship activity levels

comparable to that of the construction period. However, the comparison of visual and acoustic survey results of 2002 (baseline) and 2003 (high traffic operational phase, the so-called “post-construction period”) gave evidence that the frequent ship passages for the wind farm maintenance had little effect on the presence of harbour porpoises at Horns Rev. Before the construction of the wind farm, the Horns Rev area has been subject to a high level of fishing boat activities, transit passages and other ship traffic due to the proximity to the port of Esbjerg. The authors hypothesise that this baseline situation contributed to the result of this study, and state that in areas with previously low levels of boat traffic, a wind farm related increase in the passage rate could have a stronger effect on harbour porpoises.

#### **HILDEBRAND (2004):**

As reviewed by HILDEBRAND (2004), peak spectral densities estimated from a model developed by the U.S. Navy for individual ships range from 195 dB re  $\mu\text{Pa}^2/\text{Hz}$  (source level at 1 m) for fast moving super-tankers, to 140 dB re  $\mu\text{Pa}^2/\text{Hz}$  (source level at 1 m) for small fishing vessels. The peak frequency of a 12 m fishing vessel at 7 knots is given as 300 Hz (whole band width of noise 250 to 1000 Hz), with a source SPL of 150 dB re 1  $\mu\text{Pa}$ .

#### **NEDWELL & HOWELL (2004):**

The authors record the acoustic emission of a 25 m tug boat pulling an empty barge at a level of 170 dB re 1 Pa @ 1 m source level (quoted from RICHARDSON *et al.* 1995) as a likely scenario during offshore wind farm construction. Derived from  $1/3$  octave band levels, the spectrum shows peaks between 100 and 1000 Hz. In addition to the construction and maintenance shipping activities, a possible increase in tourism related traffic, both private and commercial, is cited. While the sound of actively moving boats is mainly produced by the propeller, the acoustic emission of stationary (or very slowly moving) vessels is predominately the radiated noise from the hull, with both factors contributing to the situation at a wind farm site. NEDWELL & HOWELL (2004) summarise evidence of the reactions of harbour seals fleeing into the water when boats approach the haul-out sites. However, due to the fact that this flush behaviour was also observed in response to canoes and kayaks, it is suggested that visual cues are in this case dominant over acoustic disturbance.

#### **BOOIJ (2004):**

In a report reviewing the situation of cetacean in the Dutch North Sea, BOOIJ (2004) quotes data on the sound emission of five ferries, ranging in length from 15 to 100 m and travelling at speeds of between 8 and 14 knots. The noise measurements show frequency ranges between approx. 20 Hz and 10 kHz, with peak frequencies around 40 Hz, where source levels were between 155 and 175 dB re 1  $\mu\text{Pa}$  (band width was 1 Hz). An auxiliary ship at 11 knots showed produced sound at a broader spectrum of 5 Hz to up to 40 kHz, reaching peak pressure levels of 153 and 145 at frequencies of approx. 10 Hz and 600 Hz, respectively.

#### **BUCKSTAFF (2004):**

In a recent investigation, an effect of boat noise on the vocal performance of 14 free ranging bottlenose dolphins was found. The author notes that the whistle rate significantly increased at the onset of vessel approaches, and postulates either an

expression of increased excitement by the animals, who signal other group members to establish visual or physical contact, or a countermeasure to overcome signal masking caused by the rising background noise. The recorded whistles covered a frequency range of 3 – 23 kHz, while the watercraft noise ranged between 0.5 – 12 kHz; thus the two sources share some frequency bands. During and after ship passage, the frequency of whistles by the observed dolphins decreased. Difficulties in this study include the unknown sound levels received by the observed individuals and the unevaluated effect of the presence of the research vessel.

### **HERR (2004):**

The study conducted by HERR (2004) represents the first approach to evaluate parallel data (in space and time) on sightings of marine mammals and ships obtained by airborne visual surveys. The categories registered were “harbour porpoises” and “seals”, the latter including harbour seals and grey seals. A significant negative correlation between the sighting frequencies of marine mammals and ships was found. This was the case for porpoises and seals pooled as well as for each category separately. The declarative strength of this result is weakened by a high percentage of fields of the grid where non-paired results were obtained (either only ship or only mammal observations), which may cause a bias in the result. After exclusion of these fields from the analysis, no significant effect of ship density on harbour porpoise density could be found, while for seals the relation was even reversed into a positive correlation. The author suggests that even if a disturbance due to boat noise did apply, the animals might not have the option of leaving the area due to their dependence either on the land access (in case of the seals) or on the local food resources. Tolerance of impacts might therefore also indicate the ecological importance of the habitat; the negative effects of interference by human activity should then not be underestimated.

The methodology was found to be promising; however, the effects of shipping activities on marine mammal abundance could not be conclusively investigated. A higher and – both in time and space – more balanced monitoring effort is suggested for future investigations, though that may be difficult for such logistical reasons as e.g. weather conditions and decreasing observance time with increasing distance from shore. An application of this method to the Baltic Sea and the consideration of a broad set of ecological parameters is encouraged.

According to the list of ships used to conduct offshore wind farm related work under the flag of European countries (OILFIELD PUBLICATIONS 2003), the size of vessels ranges from 8 to 73,887 GRT and 11 to 217 m length (under the German flag: 165 to 17,500 GRT and 27.3 to 165.9 m length), and they are equipped with machines of between 99 and 114,432 hp (under the German flag: 784 to 10,872 hp).

### **Conclusion**

Boat noise can be considered an almost constantly present factor, but in comparison to other wind turbine related sound emissions, a lower-level disturbance to the marine mammals. Nevertheless, even though almost omni-present, shipping noise varies between areas and differences might also exist in the exposure individual animals or groups of animals have experienced prior to the construction of the wind turbines. This could explain the differences in habitat use by harbour porpoises at different wind farm sites (cf. Chapter 9.2).

Boat noise also has a strong potential for a cumulative effect on animals in conjunction with other anthropogenic factors. Boat noise is a source of fairly rather continuous sound which already affects most of the continental shelf. The increase in background noise by up to 15 dB over the past decades in the North Atlantic and Pacific as well as the eastern Pacific is mainly attributed to the increased ship traffic in these regions (HILDEBRAND 2004), and any further increase will add to that. Moreover, each phase of the development of offshore wind farms will be accompanied by shipping activity of different types and intensities, thus increasing the overall noise budget for the marine mammals.

## 14 Mitigation Measures to Reduce Acoustic Impact on Marine Mammals

Two different categories of measures are considered: (i) methods to keep marine mammals away from zones of strong impact (deterrence), and (ii) techniques to minimise the level of sound emitted (sound mitigation).

### 14.1 Acoustic Harassment Devices (AHD)

Animals that are attracted to food concentrations (e.g. in fishing nets or fish farms) have been found to habituate to constant sounds that originally were intended to scare them. Over time, a marked “dinner bell effect” of the emitted sound can develop. Without the lure of the food source, marine mammals may be more easily and persistently scared (cf. RICHARDSON *et al.* 1995). The use of AHDs before events of e.g. pile driving or explosive removal activities is comparatively free of a dinner bell effect; however, after impulses, floating stunned or dead fishes have been observed to attract seabirds (SFOBB).

The acoustic characteristics of three commercially available seal AHDs were measured by LEPPER *et al.* (2004). The tested devices employ very different signalling methods, resulting in complex and wide ranging spectral and temporal contents. Their maximum source level ranges between 179 dB below the arbitrary 193 dB re 1 $\mu$ Pa at 1m. All systems tested had measurable and varied spectral content away from the discussed peak level frequencies. Even though such devices were used to deter seals, they have been shown to be effective in driving other marine mammals away (e.g. Orcas, MORTON & SYMONDS 2002). OLESIUK *et al.* (2002) and JOHNSTON (2002) documented the same effect of AHDs on harbour porpoises. An AHD (10 kHz, 170 dB re 1 $\mu$ Pa at 1 m) was used e.g. during the construction of the Horns Rev wind farm to deter seals (TOUGAARD *et al.* 2003A). In the course of the ramming activities, a visual survey was conducted to study the potential effect on the distribution and behaviour of harbour porpoises. Due to the temporal overlap with the ramming sounds, the effectiveness of the AHDs could not be assessed.

Comparable devices, so-called “pingers”, have been developed to specifically deter harbour porpoise from bottom-set gill nets, as thousands of them became entangled in these nets. The effectiveness of devices has been tested in various studies (in captivity: KASTELEIN *et al.* 1995, 1997, 2000, LOCKYER *et al.* 2001, TEILMANN *et al.* 2000; in open water: KOSCHINSKI & CULIK 1997, LAAKE *et al.* 1998, COX *et al.* 2001, CULIK & KOSCHINSKI 2001). COX *et al.* (2001) as well as TEILMANN *et al.* (2000) documented that the initial

deterrence effect of pingers emitting a consistent type of sound vanished after a certain exposure duration, as the animals obviously habituated to the sound. Pingers emitting a variety of sounds in a random sequence in contrast proved to be more effective. These devices were significantly effective in reducing the by-catch and no habituation effect could be documented (TEILMANN *et al.* 2000, LOCKYER *et al.* 2001). Their effective deterrence range is considered to be below 1 km, even though they might be audible over wider ranges. Pingers (broadband 50 – 200 kHz signal, 153 dB re  $\mu\text{Pa}$  @ 1m) were used during the construction of the wind turbines at Horns Rev (TOUGAARD *et al.* 2004).

However, almost no information is available on the potential effect of the acoustic emissions of AHDs and pingers on the hearing sensitivity of harbour porpoises, or on non-target species (see JOHNSTON 2002 for review)

## 14.2 Soft-Start Procedure

One mitigation measure adopted e.g. by the UK seismic operators with regard to marine mammals is the slow increase of the number of sound signals as well as the emitted sound energy during the initial phase of seismic surveys (CALTRANS 2001). The theory behind this approach is to give any animal in the vicinity of a seismic array the chance to leave the ensonified area before the maximum sound pressure level is reached. Therefore this procedure is conducted over a period of 15-30 minutes. This so-called “soft start” or “ramp-up” procedure is based on the assumption that an animal will be able to locate the sound source and be deterred by the comparatively lower sound levels. Soft starts are one of several mitigation measures recommended by the Joint Nature Conservation Committee (JNCC 2004) in order to minimise acoustic disturbance to marine mammals from seismic surveys. A drawback of this method, as discussed by GORDON *et al.* (1998), is that the total amount of sound energy released into the marine environment increases and potentially increases the risk of lower-level disturbance. Nevertheless this method has also been used as a mitigation measure during the construction of the Horns Rev wind farm (TOUGAARD *et al.* 2003a). So far, the number of sightings has been too small to come to a firm conclusion on the effectiveness of this method as a mitigation tool (STONE 2003). Indications for its efficacy exist (cf. Chapter 8.1), but it needs to be studied in greater detail, as its effect could fade if the gradient of sound increase between successive impulses is too small for the animals to detect. Therefore, a faster, i.e. shorter soft-start procedure could be more effective than the currently recommended procedure.

## 14.3 Bubble Curtains

The concept of using bubble curtains as a sound mitigation tool is based on the impedance mismatch between water and the air (bubble) layer. By constantly pumping air through a perforated tube located around the base of a given sound source (e.g. a pile that is to be rammed into the ground), it is possible to create a so-called bubble curtain which will effectively reduce the noise level outside it by scattering and resonance effects. It can even absorb highly intensive shock waves (e.g. generated by explosions), and thus minimise damage to structures. Several types of bubble curtain have been developed and tested for their efficacy and potential effect in mitigating effects on the marine environment, but their applicability must still be tested under offshore conditions (greater water-depths and stronger currents).

### PIDP (CALTRANS 2001, RODKIN *et al.* 2004):

One of the optional mitigation methods tested during the impact pile driving for the PIDP was a simple ring system creating a single unconfined layer of bubbles around the test pile. The analysis revealed that this system was not functional in reducing the maximum sound pressure level, but only in reducing the signal components above 800 Hz. A fabric barrier system with aerating mechanism provided a constant, confined bubble curtain that was also resistant to currents. A large metal frame was necessary to hold the two layered fabric in position. This technique (with air bubbles on) proved to be effective in reducing the maximum sound pressure level by 10-25 dB and also effectively reduce the components above 800 Hz (Fig. 20).

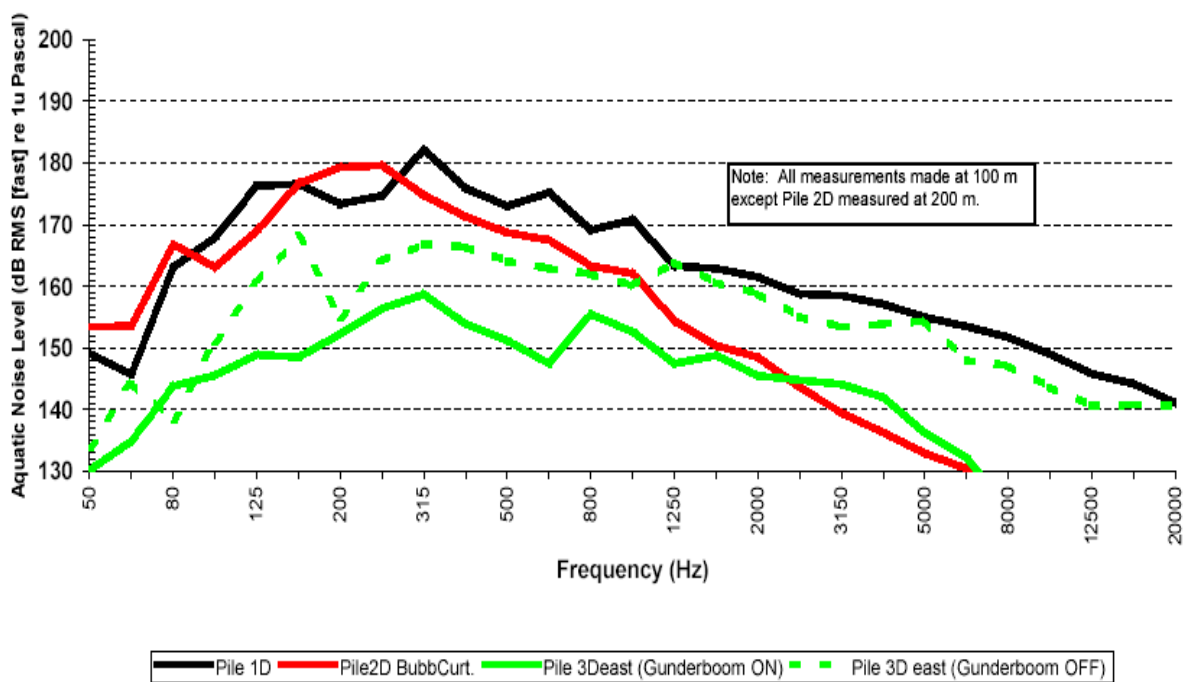

Fig. 20: Summary of representative underwater noise spectra for different noise attenuation systems used during the PIDP. Black line: no attenuation; red line: single layered, unconfined bubble curtain; green dotted line: fabric barrier system – non aerated; green line: aerated fabric barrier system (from: ILLINGWORTH & RODKIN 2001)

Based on these results, the 185 m MMSZ around the strike site of an unattenuated pile was not further reduced when a simple bubble curtain was used. However, the sound mitigation of the fabric barrier system led to a reduction of the MMSZ radius to 100 m (CALTRANS 2001). The authors reported that the three California sea lions observed near the pile driving site responded to the ramming noise by rapidly leaving the area, regardless of whether the fabric bubble curtain was used or not. No sea lions were observed during the use of the simple bubble curtain (CALTRANS 2001).

Meanwhile a two-ring bubble curtain system has been developed and tested. The results are not available yet in detail, but are to be published in an international journal (RODKIN, pers. comm.).

### VAGLE (2003):

A small version of a single ring system was used by VAGLE (2003) to generate an unconfined bubble curtain. At a water depth of 7 m and no current, this system revealed

an attenuation effect of 18 - 30 dB at frequencies between 10 and 20 kHz. However, as no information on the acoustic measurement system is provided by the author, it is impossible to assess the declarative strength of these results.

**WÜRSIG *et al.* (2000):**

The bubble curtain generated during the construction work in waters off Hong Kong was generated by single hoses (inner diameter: 50 mm) resulting in a single layered, unconfined bubble curtain. The broadband pulse levels of the percussive hammer blows were reduced by 3-5 dB due to the bubble curtain, with its greatest attenuation in the frequency range from 400 to 6400 Hz.

#### **14.4 Isolation Piles**

An isolation pile was used as a sound mitigation measure during pile installation at the Benicia Bridge (ILLINGWORTH & RODKIN 2001). This method involved installing an oversized diameter pipe around the pile before ramming. The remaining water could either be pumped out or aerated to decouple the pile from the water column. This system yielded a sound reduction of 20-25 dB either with bubbles or no water.

#### **14.5 Other Sound Mitigation Measures**

##### *Cofferdams*

For ten of the seventeen pile foundations of the San Francisco Oakland Bay Bridge, a structure of drained cofferdams was used during ramming activities. Here, the MMSZ was 150 m, again based on hydroacoustic data collected during previous pile driving (no further details were given in the cited report). As the activities in the San Francisco Bay took place in a water depth of less than 15 m, the technique may not be applicable for offshore wind turbine installation.

##### *Operational sounds of wind turbines*

Any attempts to reduce the measured operational sound of a wind turbine would have to aim at minimising the gear mesh vibrations reaching the tower structure by designing effective vibration isolation (INGEMANSSON TECHNOLOGY AB 2003). The authors state that since the emitted frequencies are relatively high even stiff isolators could reduce the vibrations considerably. Furthermore they call for an isolation of the wet surface of the tower from direct contact with the water. By inserting a layer (e.g. a foamed polymer) between the tower and water the emitted noise could be reduced significantly.

#### **Conclusion**

To date, most efforts has been concentrated on bubble curtains and a substantial effect has been documented for this technique in combination with fabric barriers. However, this approach must be tested for its efficiency and applicability in the construction of wind turbines e.g. in the North Sea. The use of isolation piles shows a comparable acoustical effectiveness, and may be better suited to attenuate sound, especially during the installation of wind turbine foundations in offshore areas.

The available techniques should be tested for their applicability with regard to the special requirements for installing wind turbine foundations (e.g. the dimension of the pile, water depth, currents). Alternative mitigation techniques (as will be tested in San Francisco e.g.) should be developed and all methods should always be based and maintained on the best available practise.

Ever more wind farm projects are currently being authorised, but their ecological effects are still subject to on-going scientific research. As sound emissions are one of the greatest concerns in this context, the measures for attenuating wind turbine related sound emissions represent the best and most realistic strategy for reducing potential negative effects on the marine environment.

## 15 Conclusions – Progress and Research Needs

Obviously, offshore wind farm development has kept up its momentum in recent years, and progress has been made in a number of aspects with regard to the information needed for assessing the potential effects on the marine environment. Comparable attempts to study these effects have been started in various countries, and good coordination of these efforts, as well as increased exchange of information internationally seems highly advisable. This could save resources, speed up the process due to synergistic effects, and provide higher quality data.

Much effort has been put into studies on the distribution and abundance of marine mammals. This kind of information is indispensable as a baseline for assessing potential effects on the distribution and abundance of these animals by the construction and operation of wind turbines in any area.

More information has also been compiled regarding wind turbine related sound emissions. On this and other issues, some knowledge can be gained from studies on related activities (e.g. pile driving for bridge construction, seismic activities for oil exploration and their effects on marine mammals).

Nevertheless, for these issues, and even more so for many other important parameters, the lack of data is still enormous. For example, the knowledge on the general biology of the target species is far from being complete, as many basic parameters, such as diet, behaviour, or habitat use are poorly understood to date. On the other hand, the planned offshore wind power development involves a variety of activities both on a temporal and a spatial scale which could affect marine mammals in numerous ways. Therefore, compiling the available information results in an extensive list of demands for further research covering issues of both individual-level effects and population-level effects. Without assessing the effects at the individual level, it is impossible to identify the cause-effect relationship and provide sound solutions to mitigate or prevent negative or unwanted effects.

More information on marine mammals is need in the following areas (unranked):

- **Diet** (seasonal changes in diet, feeding grounds, energy demand): Dietary information can be gained through fatty acid analysis of by-caught or stranded animals as well as their prey items. The energy demand can best be studied on captive animals and by telemetry studies e.g. using IMASENS (Inter-Mandibular-Sensors) which will reveal information on feeding events.



- **Reproduction** (mating period and areas, breeding grounds, nursing areas and period): Pathological examination can reveal important information in this respect. This information along with further aspects of the general biology of the marine mammals is also needed to determine the maximum growth rate [r] of a given population in the model.
- **Migratory patterns:** This type of information can be gained through satellite telemetry studies. The Danish and German telemetry studies on seals and porpoises have already revealed valuable information. However a combination of both tagging methods as well as a higher number of animals studied is required in order to get reliable data. No telemetry data exist on the movements of harbour porpoises in the North Sea.
- **Criteria of habitat selection:** A multidisciplinary approach is needed to study biotic and abiotic parameters – sighting surveys should be combined with T-POD deployments, dedicated fish studies to gather information on the food availability and oceanographic measurements (currents, salinity, temperature etc)
- **Behaviour** (under normal conditions as well as reactions to disturbance, habituation and sensitisation): the latter can best be studied by conducting Controlled Exposure Experiments (CEEs). The satellite tag combined with a datalogger unit recording the activity pattern of the marine mammal as well as acoustic signals (from the animal as well as anthropogenic signals) would be the ideal method in this respect. Any changes in behaviour due to repeated exposure can be tested in captivity but data from free-ranging animals would provide a higher declarative strength to the data.
- **Acute and chronic stress:** Stress can be acute or chronic, depending on the exposure situation and duration. It can lead to reduced reproductive success, a reduced function of the immune system and in general reduced fitness of the animals at risk. No studies have been conducted with regard to offshore wind turbines and marine mammals. Those effects can be studied by health assessment or cytokine studies.
- **Habitat use:** can be studied with stationary acoustic loggers (T-PODs) in harbour porpoises and satellite telemetry in combination with dataloggers in all three target species. Like the telemetry studies on harbour seals in German and Danish waters as well as on harbour porpoises in Danish waters the T-POD studies provide already indispensable data on the importance of specified areas. So far they do not provide enough data yet to come to final conclusion and the studies should be continued. A promising attempt would be the correlation of this type of data with behavioural observations and visual survey data on abundance and distribution. It seems appropriate to recommend this method as a standard for environmental impact studies on offshore wind farm farms.
- **Acoustic parameters** (audiograms, TTS, masking effects, vocalisation): hearing related parameters can best be studied by conducting ABR studies on both captive and free ranging animals. Ethological studies in combination with sound recordings can provide information on context specific vocalisations.
- **Abundance and distribution:** These parameters can best be established by conducting ship based surveys as well as aerial sighting surveys for harbour porpoises and aerial counts for seals. Telemetry studies on seals and porpoises can reveal important correction factors to these data. However, due to the different size of the target areas the survey effort differs strongly on a temporal and spatial scale between the numerous surveys conducted so far. All these studies need to be

continued at constant efforts in order to provide sufficient data for a BACI analysis, i.e. for detecting effects. As the first large scale wind farm are now in operation, it will be possible to gather data on the actual impact of these wind farms. These data will be an important input to the effect model.

With regard to the non-biological parameters further information is needed on:

- **Acoustic monitoring (background noise, construction, operation):** A small but growing number of recordings of wind turbine related sounds have been conducted and published so far. The recordings are useful in order to understand the acoustic dimensions of the wind turbine related noise. However, so far only a limited amount of information can be drawn from these recordings as in general they were made from different wind turbine types and sizes, different types of foundation and different depths. All this will result in sound pressure levels and spectral densities which can significantly differ, especially with regard to different bottom substrate. So, systematically conducting further recordings during all phases will be one of the research needs.
- **Acoustic mapping:** Only few information exist on the total acoustic load at a selected wind farm site. This type of data is indispensable for assessing the cause-effect relationship between sound and the behaviour and habitat use of the animals. A sound mapping should comprise a correlation of natural background noise (including weather dependent variability) with emissions of other anthropogenic sound sources. Such efforts can be conducted on a national or an international level.
- **Mitigation measures:** Effective measures to reduce the acoustic emissions during the construction phase of offshore wind turbines are currently being developed and tested (cf. CALTRANS 2001). Much more knowledge is available by now and it seems likely that these techniques can be adopted for the installation of wind turbines also under North Sea conditions.

**Pre-construction phase and decommissioning:** These aspects have been completely neglected to date in wind turbine related studies, and knowledge is scarce on the effects of the devices used on marine mammals in general. The few data that exists suggest that especially seismic surveys used in wind farm site investigations should be a subject of concern, but there is a need for further investigation on the effects of all techniques used in this respect. However, for an initial assessment, knowledge of potential effects could also be taken from other studies, as the devices used for site investigations and for decommissioning facilities will be similar.

## 16 Modelling the Effects of Offshore Wind Farms on Harbour Porpoise Populations: Parameters, Model Structure, Scale and Needed Data

As the current knowledge is still insufficient in many respects to quantify the effects of offshore wind turbines on harbour porpoise populations or any other chosen scale, it is necessary to apply an appropriate model in order to translate the observed individual-level effects into potential population consequences.

A potential modelling approach is outlined here in terms of the parameters, model structure, and required input data. The basis of the modelling approach is to determine the extent of effective habitat reduction, express this in terms of the environmental carrying capacity reduction, and hence determine the population consequences using a simple demographic model. Possible direct mortalities of harbour porpoises due to Wind turbine activities are not considered.

The model could also be helpful for the assessment of cumulative effects. So far there is no information available on the cumulative effects that several wind farms might have. A number of anthropogenic activities already exist which have proven to have a substantial effect on marine mammals. Amongst the most important is the by-catch of harbour porpoises in bottom set gill nets which cause a mortality of several thousand animals per year. Other factors include the depletion of fish stocks in European waters, chemical pollution, etc. The effect that each of these factors has on the population may or may not reach a level which is no longer sustainable for a population. Every population in the wild can cope with additional anthropogenically induced mortalities to a certain extent. But after a certain level, the number of mortalities cannot be compensated and the population level decreases. An obvious conclusion is that of course no factor stands alone. All factors are cumulative and must be assessed together by discussing the significance of effects.

The model has not been implemented at this time. This will be done in a later work if it is thought that the approach has merit.

### 16.1 Factors Included in the Model

Modelling the effects of offshore wind power developments on harbour porpoise populations shall incorporate the following factors:

#### *Population-level parameters*

- Identity of discrete harbour porpoise populations and ranges of each
- Current abundance, carrying capacity ( $K$ ), and growth rate ( $r$ ) of each population;
- Optional additional population parameters: age-specific fecundity and survival rates;
- Other anthropogenic impacts on the population, e.g. by-catch rate

### *Distribution of porpoises*

- Density of porpoises, mapped geographically, for direct observations, or by fitting a spatial model of porpoise density to available data
- Optionally separate into summer/winter distributions

### *Extent of offshore wind power developments*

- Areas of actual, approved, proposed and projected developments
- Anticipated time schedule of developments
- Construction time
- Operation time

### *Effects of wind power development on porpoises*

- Effective exclusion area in and around wind farms during
- Construction
- Operation and maintenance
- Recovery time: how soon after construction does porpoise density recover to long term operating level?

## **16.2 Spatial and Temporal Scales For Assessment**

### *Spatial scale*

The assessment of the effects of offshore wind turbines on harbour porpoise abundance requires a choice of both:

The spatial scale at which the effects on porpoises are to be assessed, for example:

- area of actual wind farm project
- area of wind farm project plus a surrounding buffer zone
- German EEZ
- region, e.g. southern/central North Sea
- entire North Sea; and

The scale at which wind power projects are assessed, e.g.:

- single wind turbine
- single wind farm project
- all current and planned projects
- long-term maximum foreseen wind power development based on governmental energy policy

There is no single “correct” choice of scale for the assessment but the scales over which the wind power development plans on the one hand, and the effects on porpoise abundance on the other hand must be mutually relevant.

It would not be sensible, for example, to assess the effects of a single wind farm on the abundance of porpoise in the entire North Sea. While the effect of any single wind farm project on the entire North Sea population of harbour porpoise would be negligible, there may be dozens or hundreds of wind farm projects planned in the North Sea as a whole, whose combined effect could be substantial.

If it is required to assess the effects of specified wind power development plans at a certain level, then this will determine the spatial scale over which it is appropriate to assess the effects on harbour porpoises.

For example, if it is required to assess the effects of a given planned wind farm, then the effect of harbour porpoise abundance within the farm is the relevant scale, unless a wider enclosing area around the proposed farm can be defined within which there would be no further wind power developments apart from the proposed farm.

On the other hand, if it is required to assess the effects of offshore wind power development in general on a given porpoise population, then it is necessary to:

- determine the area of distribution of the porpoise population, for example the southern North Sea population;
- identify one or more reasonable scenarios for the cumulative total extent of wind power development over the area of distribution the population.

Furthermore there can be habitats within a given large area which are of different importance for the animals as clearly indicated by density distribution maps (e.g. for the harbour porpoises in the German EEZ). This importance might change within seasons as animals may use certain areas for breeding in summer, other areas as migratory pathways or feeding grounds in other seasons. It remains unclear which are the important factors, but it's likely to be a combination of biotic and abiotic parameters. Also, there is no information available to which extent the loss of an important habitat can be compensated in other areas.

### *Temporal scale*

The temporal scale over which the effects of wind power developments are to be assessed depends both on the expected lifetime of wind power installations and also on the dynamics of harbour porpoise populations.

When considering the cumulative effects of a large number of wind power projects over time, there will at any given time be a mixture of installations in operation and installations under construction. Thus, it cannot be assumed that construction impacts are only temporary.

Because of the time-lags in harbour porpoise population dynamics, the time point of the maximum effect on the population will not necessarily coincide with the time-point of maximum disturbance by wind power activities, but could come after it. The time horizon considered for modelling purposes should be long enough to include at least the time point of the maximum impact of wind power operations on the population, and preferably also long enough to indicate the expected time required for recovery, if any, of the population following the maximal impact. A time period of 25-50 years will likely be found to be most appropriate.

### 16.3 Modelling of Wind Turbine Effects: Preliminary Considerations

The main potential effect of wind turbines is presumed to be temporary or permanent (partial) exclusion of porpoises from part of its habitat.

The relevant parameter for a given wind farm is the *Effective Exclusion Area*. In the case that there is no complete exclusion of porpoises from the neighbourhood of the development, the effective exclusion area is defined as the weighted sum of partial exclusion areas. For example if the porpoise density is reduced by 75% within a wind farm covering 20 km<sup>2</sup>, and by 35% within a surrounding area of 80 km<sup>2</sup>, then the effective exclusion area is given by  $A_E = 20 \cdot 0.75 + 80 \cdot 0.35 = 43 \text{ km}^2$ . This is a measure of the loss of useable porpoise habitat due to the wind farm.

It is expected that the effective exclusion area is greater during the construction phase than during the operational phase.

The effective exclusion area can be measured in a variety of ways, each of which has its own limitations and problems.

The approach already used in the case of two Danish wind farms is to measure the density of harbour porpoises (acoustically using PODs) before, during and after construction, both on and around the wind farm site itself and in a suitable reference area.

A limitation of this approach is that the use of a reference area is a relatively crude means of correcting for non-wind turbine related changes in density of porpoises. The reference area must be far enough away from the wind farm site to be confident that there are no wind turbine effects on the reference area. On the other hand, it must be near enough to be reasonably confident that any non-wind turbine factors causing a change in density will affect both sites equally.

A further limitation is that porpoise density tends only to be measured in one season before construction. This diminishes the power to detect changes if there is substantial inter-annual variability in actual or measured porpoise density in the development area.

An alternative approach is to use spatial models of harbour porpoise density to estimate the degree of density anomaly associated with wind farm construction and operation. This overcomes the restriction to before-and-after comparisons. Porpoise density data collected at any time can be used.

The spatial modelling method can run into problems if there is strong confounding between the presence of wind farms and other environmental covariates. The confounding is only likely to become a problem if either (a) large, continuous areas are developed for wind power; and/or (b) the radius of effect of windpower construction and/or operation is large, so that large, continuous areas are affected.

### 16.4 Model Structure and Input Data

#### 16.4.1 Population Identity

The presumed identity and ranges of the discrete harbour porpoise populations needs to be specified. According to current understanding, there are: southern North Sea; central North Sea; Kattegatt/Lesser and Greater Belts, Kiel Bight; Baltic proper. The collection and analysis of genetic material should be continued to further refine this

understanding and to determine both the minimum number of discrete populations and the most appropriate boundaries between them.

While genetic differences are strong indicators of discrete populations, the reverse is not the case. Genetic studies indicate only the minimum number of discrete populations. Tracking studies provide the converse information: movements of animals between areas can be taken as evidence of population interchange, but lack of observed movement tends to be inconclusive, due to limited sample size.

When more data become available, it may be appropriate to distinguish between the winter and summer ranges of each population.

#### 16.4.2 Population Dynamics

The population can be modelled either as a bulk process or in more detail as an age- and sex- structured model. It is not expected that there will be substantial differences in the predictions of the two types of model, but the more detailed model lends itself more readily to the incorporation of additional factors at a later stage.

##### *Bulk model*

The simplest bulk population model is:

$$P_{t+1} = P_t(1 + r(1 - P_t/K))e^{-F_t}$$

where:

$P_t$  population size of harbour porpoises in year  $t$

$r$  maximum growth rate

$K$  carrying capacity (equilibrium population size in the absence of anthropogenic effects)

$F_t$  by-catch mortality rate in year  $t$

The value of  $r$  is difficult to measure in the field, and hence it is necessary to make use of “conventional” values such as 0.04 as adopted by the IWC-ASCOBANS Working Group on Harbour Porpoises. The value of  $K$  is determined by fitting the population model through the available estimates of recent or current population size, given a time series of assumed by-catch mortality rates.

Estimates of population size for the North Sea in 1994 were obtained in the SCANS survey, and newer estimates are expected from the SCANS 2005 survey.

### Age- and sex-structured model

An age- and sex structured model of the population is defined as follows:

$$P_{i+1,t+1} = S_i P_{i,t} e^{-F_{i,t}} \quad (0 \leq i < m)$$

$$P_{m,t+1} = S_m P_{m,t} e^{-F_{m,t}} + S_{m-1} P_{m-1,t} e^{-F_{m-1,t}}$$

$$P_{0,t+1} = \frac{1}{2} \sum_{i=1}^m f_i P_{i,t}$$

where:

- $P_{i,t}$  number of female harbour porpoises aged  $i$  alive in year  $t$
- $m$  age of plus group (*not* maximum age) (e.g. if  $m = 10$ , animals aged 10+ are lumped together)
- $F_{i,t}$  by-catch mortality rate of females aged  $i$  in year  $t$
- $S_i$  natural survival rate of females aged  $i$
- $f_i$  reproductive rate of females aged  $i$ , defined as the probability of producing a *surviving* calf

Similar equations apply to the male population.

The incorporation of density-dependence into the age-and sex-structured model is not quite as simple as for the bulk model. Density-dependence is conventionally applied to the reproductive rate only. Reproductive rate is conveniently expressed as a logistic function of age-specific factors and a density-dependent factor:

$$f_{i,t} = 1 - 1/(1 + \exp(\alpha + \phi_i - \beta P_t))$$

where

- $\phi_i$  age-specific factors based on information on age-specific fecundity
- $\alpha$  a parameter whose value is chosen to yield the assumed value of  $r$
- $r$  the maximum population growth rate
- $\beta$  determines the value of  $K$ , and is fitted just as  $K$  is fitted for the bulk model.

### 16.4.3 Modelling the Distribution of Porpoises

The distribution of porpoises is most effectively modelled using spatial modelling techniques. The major advantage of spatial modelling is its flexibility and the ability to incorporate a variety of data sets on porpoise abundance in to a consistent framework. Gaps or “holes” in the available data are filled automatically in the statistically most appropriate way. The resulting uncertainty is readily quantified in the statistical fitting process.



A vector of covariates is chosen, such as depth, water temperature, salinity, latitude and longitude. A generalised additive model using these covariates is fitted to the available data on harbour porpoise occurrence, including the German aerial surveys, SCANS and other sources.

If  $\mathbf{z}(\mathbf{x})$  denotes the vector of covariates at position  $\mathbf{x}$ , a porpoise log-density function  $f(\mathbf{z}(\mathbf{x}))$  is fitted to the data. The fitted total abundance in an area  $A$  is given by the integral of the density function over the area:

$$\hat{N}_A = \int_A \exp(f(\mathbf{z}(\mathbf{x}))) da(\mathbf{x})$$

where  $a(\mathbf{x})$  denotes area measure at position  $\mathbf{x}$ .

#### 16.4.4 Modelling the Effects of Offshore Wind Turbines

The effects of offshore wind turbines are taken into account by including covariates related to proximity to wind turbine developments, in the spatial porpoise density model. If  $\mathbf{w}(\mathbf{x})$  denotes the vector of offshore wind turbine-related covariates at position  $\mathbf{x}$ , then let  $g(\mathbf{w}(\mathbf{x}))$  be a function representing the additive effect of offshore wind turbines on the log-density (i.e. a multiplicative effect on density).

The function  $g$  should be chosen so that the effects are zero away from the range of influence of an offshore wind turbine activity. For example, if  $r(\mathbf{x})$  is the distance from the point  $\mathbf{x}$  to the nearest generator in a wind farm, then  $g(\mathbf{x})$  would have the form:

$$g(\mathbf{x}) = a / (1 + br(\mathbf{x}))$$

where  $a$  and  $b$  are parameters that might depend on characteristics of the wind farm. On the assumption that offshore wind turbine has a negative effect that becomes smaller with increasing distance from the farm, the value of  $a$  will be negative and the value of  $b$  positive.

The fitted impact of offshore wind turbines on the abundance of porpoises in an area  $A$  is then given by the difference between the integrals of the density functions with and without the factor relating to offshore wind turbines.

$$\Delta \hat{N}_A = \int_A \exp(f(\mathbf{z}(\mathbf{x})) + g(\mathbf{w}(\mathbf{x}))) da(\mathbf{x}) - \int_A \exp(f(\mathbf{z}(\mathbf{x}))) da(\mathbf{x})$$

This can be considered an estimate of the number of porpoises displaced from the area  $A$  by offshore wind turbines.

### 16.4.5 Modelling the Population Consequences of Offshore Wind Turbine Impacts

In the short term, the porpoises displaced by offshore wind turbine activities are not lost to the population, but are merely displaced to other areas. However, the effective reduction in available habitat will diminish the environmental carrying for the population. The parameter  $K$  in the population model should be adjusted by the running sum of all the displacements due to offshore wind turbines. This will vary with time according to the actual and projected development of wind power over time.

When  $K$  is allowed to vary with time in this way, an assumption needs to be made about the corresponding changes in  $r$ . The most optimistic assumption is that  $r$  is unaffected by changes in  $K$ . An alternative model is McCall's constant-slope logistic model, motivated by his "basin model" of habitat occupation. Under this model  $r$  is proportional to  $K$ , such that if  $K$  changes to  $K^*$ , then  $r$  changes to  $r^* = rK^*/K$ .

If the age- and sex-structured model is used, then McCall's model involves keeping the slope parameter  $\beta$  fixed while  $\alpha$  varies.  $K$  and  $r$  are functions of  $\alpha$  and  $\beta$ . When  $K$  changes, a new value of  $\alpha$  is computed that yields the new value of  $K$ . The resulting new value of  $r$  can then also be computed.

Because there is little prospect of being able to obtain data to distinguish between these assumptions, both options will need to be applied in every case, yielding a more optimistic and a less optimistic scenario.

The population model can be projected forward for any given offshore wind turbine development scenario.

An offshore wind turbine development scenario involves specification of the location, size, shape, type and number of generators, starting year of construction, ending year of construction, and planned lifetime of each actual or anticipated wind farm.

The projected population "effect" of a given offshore wind turbine scenario is the difference between the projection for that scenario and the projection for the scenario without offshore wind turbines.

Parameter uncertainty is taken into account by making not a single projection, but a probability distribution of projections by drawing parameters randomly from their posterior probability distributions after fitting the relevant data.

### 16.4.6 Data Requirements

To implement the modelling approach outlined above, the main specific data requirement is for data on porpoise density for fitting the spatial model. The porpoise density data required is of two main kinds:

- (i) data from the entire area of interest for the porpoise of estimating the overall density function  $f$ ;
- (ii) data collected in the vicinity (e.g. within and within a few km of) of offshore wind turbine sites, before, during and after construction for the purpose of estimating the function  $g$  that represents the effects of offshore wind turbines on porpoise density.

data of type (i), because of the broad spatial scale, are most effectively collected from aerial surveys, as are already conducted within the German EEZ;

Data of type (ii), covering a smaller spatial scale in the vicinity of offshore wind turbine sites, may be more effectively collected from fixed stations using acoustic PODs.

Data collection near offshore wind turbine sites should not be delayed until immediately before construction, but should begin as soon as prospective sites are identified, because the longer the period over which data are collected, the more reliable the estimates of offshore wind turbine effects will become. Following construction, data collection should be continued indefinitely.

Data collected must be of scientific quality and should be peer reviewed.

Data on overall porpoise abundance, stock identity, and other anthropogenic impacts, especially by-catch mortality rates, are also required as inputs into the model, but it is anticipated such data will be collected for purposes beyond the offshore wind turbine context.

### *Research Needs*

Currently the model presented would have to be based on numerous assumptions as several parameters can't be quantified yet. The quality of the model and its results will clearly increase with an increasing knowledge on many of parameters discussed in chapter 13. Furthermore it will be important to gather more information on the stock identity of the marine mammals. Therefore, in addition to the research need already identified, it will be necessary to gather genetic information on the different species from different areas within their distributional range.

Other effects like by-catch, pollutants and food depletion are evenly important as the effect of wind farms has to be assessed in conjunction with effects of other anthropogenic factors. The most important one for harbour porpoises is bycatch, disturbance due to other anthropogenic sound sources, as well as pollution and food depletion, are factors influencing seals and whales alike. More information on the actual influence of the factors on the marine mammals is strongly needed. These information will also be important for the quality of the modelling results.

## 17 References

- AKAMATSU, T., HATAKEYAMA, T. & SOEDA, H. (1994): Echolocation rates of two harbor porpoises (*Phocoena phocoena*). *Mar. Mamm. Sci.*, Vol. 10(4): pp. 401-411.
- ANDERSEN, S. (1970): Auditory Sensitivity of the Harbour Porpoise *Phocoena phocoena*. In: *Investigations in Cetacea*, Vol.2, pp 255-259.
- ANON. (2000): *EPIC - Elimination of Harbour Porpoise Incidental Catches*, Project no. DG XIV 97/0006, Final report.
- ANON. (1999): *Abrasive water-jet cutting for platform removal and well abandonment*. Oil States MCS.
- ANON. (2000): *Basic Study/Surveillance of Porpoises at Horns Rev*.
- ANON. (2000): *Environmental Impact Assessment - Investigation of marine mammals in relation to the establishment of a marine wind farm on Horns Reef*. FSM Esbjerg, Ornis Consult A/S, and Copenhagen Zoological Museum.
- ANON (2000): Guidelines on the application of the Environment Protection and Biodiversity Conservation Act to interaction between offshore seismic operation and whales (large cetaceans)
- ANON. (2000): *Monitoring of harbour porpoise in relation to the establishment of a marine windmill park at Horns Reef*. Note for Elsam Project. FSM Esbjerg, Ornis Consult A/S, and Copenhagen Zoological Museum.
- ANON. (2000): *Oakland Harbour Navigation Improvement (50 Foot) Project*. Final Environmental Impact Report. [www.50ftdredge.com](http://www.50ftdredge.com) .
- ANON. (2000): *Selection of 180 dB as the Upper reference Point in the Risk Continuum for SURTASS LFA Sonar Signals*. [www.surtass-lfa-eis.com/docs/180dBCriteria.pdf](http://www.surtass-lfa-eis.com/docs/180dBCriteria.pdf) .
- ASCOBANS (2003): Resolution No. 5: Effects of Noise and of Vessels. 2003. 4th Meeting of the Parties to ASCOBANS, Esbjerg, Denmark.
- ATZLER, R., BARTHOLOMÄ, A., BELLMER, H., BERGMANN, J., HACHMANN, U., HARDER, H., KLOSE, M., LEMKE, W., LESNY, K., MICHELS, K., PETERSEN, P., REINHARD, L., RICHWIEN, W., RONOLD, K., SCHWARZER, K., SPIESS, V., STREIF, H. & UECKER, J. (2003): *Standard Baugrunderkundung. Mindestanforderungen für die Gründung von Offshore-Windenergieanlagen (WEA) und die Verlegung der stromabführenden Kabel*, Bundesamt für Seeschifffahrt und Hydrographie; Report BSH No. 7004 (in German).
- BENKE, H.; SIEBERT, U.; LICK, R.; BANDOMIR, B. & WEISS, R. (1998): The current status of harbour porpoises (*Phocoena phocoena*) in German waters. *Arch Fish. Mar. Res.*, Vol. 46: pp. 97-123.
- BERRYMAN, A.A. (2002): Population: a central concept for ecology? *OIKOS* 97: 439442.
- BETKE, K.; SCHULTZ-VON GLAHN, M. & MATUSCHEK, R. (2004): *Underwater noise emissions from offshore wind turbines*.
- BETKE, K.; SCHULTZ-VON GLAHN, M.; PETERSEN, A. & GABRIEL, J. (2003): *Messung der Unterwasser-Schallabstrahlung einer Offshore-Windenergieanlage*. Deutsche Jahrestagung für Akustik, Aachen.
- BJØRGESÆTER, A., UGLAND, K.I. & BJØRGE, A. (2004): Geographic variation and acoustic structure of the underwater vocalisation of harbor seal (*Phoca vitulina*) in Norway, Sweden and Scotland. *J. Acoust. Soc. Am.*, Vol. 116(4): pp. 2459-2468.
- BIGG, M.A. (1981): Harbour Seal *Phoca vitulina* Linnaeus, 1758 and *Phoca largha* Pallal, 1811. In: S.H. Ridgway and R.J. Harrison (Eds.): *Handbook of Marine Mammals*, Volume 2: Seals. London: Academic Press.
- BIRKUN, A., JR. (2002): Disturbance to Cetaceans in the Black Sea. In: Notarbartolo di Sciara, G., ed. *Cetaceans of the Mediterranean and Black Seas: state of knowledge and conservation strategies*. A report to the ACCOBAMS Secretariat. Monaco.
- BJØRGE, A. (2003): The harbour porpoise (*Phocoena phocoena*) in the North Atlantic: Variability in habitat use, trophic ecology and contaminant exposure. In: Haud, T.; Desportes, G.; Vikingsson, G. A.; Witting, L., eds. *Harbour porpoises in the North Atlantic*. NAMMCO Sci. Publ.: pp. 223-228.
- BOOIJ, J. (2004): *Improving the Dutch part of the North Sea as a cetacean habitat*.
- BUCKSTAFF, K.C. (2004): Effects of watercraft noise on the acoustic behavior of bottlenose dolphins, *Tursiops truncatus*, in Sarasota Bay, Florida. *Mar. Mamm. Sci.*, Vol. 20: pp. 709-725.

- BUSNEL, R.G., DZIEDZIC, A. UND ANDERSEN, S. (1965): Rôle de l'impédance d'une cible dans le seuil de sa détection par le système sonar du marsouin *P. phocaena*. C.R. Séances Soc. Biol., Vol.159, pp. 69-74
- CALIFORNIA DEPARTMENT OF TRANSPORTATION (2001): *San Francisco-Oakland Bay Bridge East Span Seismic Safety Project*. Pile Installation Demonstration Project. Marine Mammal Impact Assessment. PIDP EA 012018.
- CALIFORNIA DEPARTMENT OF TRANSPORTATION (2003): *Bay Bridge East Span Biological Mitigation*. <http://biomitigation.org/reports/> .
- CONTINENTAL SHELF ASSOCIATES, INC. (2004): *Explosive Removal of Offshore Structures. Information Synthesis Report*. OCS Study MMS 2003-070, pp. 1-181. New Orleans, LA, U.S. Department of the Interior, Minerals Management Service, Gulf of Mexico OCS Region.
- TARA M. COX, T.M., READ, A.J., SOLOW, A. & TREGENZA, N. (2001): Will harbour porpoises (*Phocoena phocoena*) habituate to pingers? *J. Cetacean Res. manage.*, Vol. 3(1): pp. 81–86, 2001.
- CULIK, B.M., KOSCHINSKI, S., TREGENZA, N. & ELLIS, G.M. (2001): Reactions of harbor porpoises *Phocoena phocoena* and herring *Clupea harengus* to acoustic alarms. *Mar. Ecol. Prog. Ser.*, Vol. 211: pp. 255-260.
- DAVID, L. (2002): Disturbance to Mediterranean Cetaceans Caused by Vessel Traffic. In: Notarbartolo di Sciara, G., ed. *Cetaceans of the Mediterranean and Black Seas: state of knowledge and conservation strategies*. A report to the ACCOBAMS Secretariat. Monaco.
- DEGN, U. (2000): *Offshore Wind Turbines – VVM. Underwater Noise Measurements, Analysis, and Predictions*. Ødegaard & Dannekiold-Samsøe A/S, Rep. No. 00-792 rev. 1.
- DEHNHARDT, G., HANKE, W., BLECKMANN, H & MAUCK, B. (2001): Hydrodynamic trail-following in harbour seals (*Phoca vitulina*). *Science*, Vol. 293: pp. 102-104.
- DEHNHARDT, G., MAUCK, B. & BLECKMANN, H. (1998): Seal whiskers detect water movements. *Nature*, Vol. 394: pp. 235-236.
- DEWI (2004): *Standardverfahren zur Ermittlung und Bewertung der Belastung der Meeresumwelt durch die Schallimmission von Offshore- Windenergieanlagen*. Final report. 0327528A, pp. 1-123 & Appendix, 0327528A, A-1-A-137 (in German).
- DZWILEWSKI, P. T. & FENTON, G. (2003): *Shock Wave/Sound Propagation Modeling Results for Calculating Marine Protected Species Impact Zones During Explosive Removal of Offshore Structures*. OCS Study MMS 2003-059, pp. 1-39. New Orleans, LA, U.S. Department of the Interior, Minerals Management Service, Gulf of Mexico OCS Region.
- EDRÉN, S.; TEILMANN, J.; DIETZ, R.; & CARSTENSEN, J. (2004): *Effect from the construction of Nysted Offshore Wind Farm on seals in Rødsand seal sanctuary based on remote video monitoring*. Technical report to Energi E2 A/S. 1-31. 2004. Ministry of the Environment, Denmark.
- ELSAM ENGINEERING A/S (2004): *Elsam Havmøller Horns Rev*. Annual status report for the environmental monitoring programme 1 January 2003 - 31 December 2003. 187837.
- ENERGI E2 (2004): *Annual Status Report Nysted Offshore Wind Farm*. Environmental Monitoring Programme 2003. pp. 1-45. Prepared for the environmental Committee of the Danish Offshore Windfarm Demonstration Projects.
- EVANS, P. G. H. (1998): Biology of Cetaceans of the North-East Atlantic (in Relation to Seismic Energy). In: M. Tasker and C. Weir (Eds.): *Proceedings of the Seismic and Marine Mammals Workshop*. London.
- EVANS, P. G. H. (2003): *Shipping as a possible source of disturbance to cetaceans in the ASCOBANS region*. Agenda Item 9.2: Interactions with shipping, pp. 1-58. ASCOBANS. 4th Meeting of the Parties.
- FAY, R. R. (1988): *Hearing in vertebrates: a Psychophysics Databook*. Winnetka, Illinois: Hill-Fay Associates.
- FINNERAN, J. J.; SCHLUNDT, C. E.; DEAR, R.; CARDER, D. A. & RIDGWAY, S. H. (2002): Temporary shift in masked hearing thresholds in odontocetes after exposure to single underwater impulses from a seismic watergun. *J. Acoust. Soc. Am.*, Vol. 111: pp. 2929-2940.
- FRISTEDT, T.; MORÉN, P. & SÖDERBERG, P. (2001): *Acoustic and Electromagnetic noise induced by wind mills - implications for underwater surveillance systems*. Pilot Study. FOI-R--0233--SE, 1-13. Stockholm, Sweden, Swedish Defense Research Agency.

- GASKIN, D. E. (1984): The harbour porpoise *Phocoena phocoena* (L.): regional populations, status, and information on direct and indirect catches. *Rep. Int. Whal. Comm.*, Vol. 34: pp. 569-586.
- GOOLD, J.C. & FISH, P.J. (1998): Broadband spectra of seismic survey air-gun emissions, with reference to dolphin auditory thresholds. *J. Acoust. Soc. Am.*, Vol. 103 (4): pp. 2177-2184.
- GORDON, J. C. D.; GILLESPIE, D.; POTTER, J.; FRANTZIS, A.; SIMMONDS, M. P. & SWIFT, R. (1998): The Effects of Seismic Surveys on Marine Mammals. In: Tasker, M.; Weir, C., eds. Proceedings of the Seismic and Marine Mammals Workshop. London.
- HAMMOND, P. S.; BERGGREN, P.; BENKE, H.; BORCHERS, D. L.; COLLET, A.; HEIDE-JØRGENSEN, M. P.; HEIMLICH, S.; HIBY, A. R.; LEOPOLD, M. F. & ØIEN, N. (2002): Abundance of harbour porpoise and other cetaceans in the North Sea and adjacent waters. *J. Appl. Ecol.*, Vol. 39: pp. 361-376.
- HENRIKSEN, O. D.; CARSTENSEN, J.; TOUGAARD, J. & TEILMANN, J. (2004): *Effects of the Nysted Offshore Wind Farm construction on harbour porpoises*. Annual status report for the acoustic T-POD monitoring programme during 2003. Ministry of the Environment, Denmark.
- HENRIKSEN, O. D.; TEILMANN, J. & CARSTENSEN, J. (2003): *Effects of the Nysted Offshore Wind Farm construction on harbour porpoises - the 2002 annual status report for the acoustic T-POD monitoring programme*. Ministry of Environment.
- HENRIKSEN, O. D.; TEILMANN, J. & DIETZ, R. (2001): *Does underwater noise from offshore wind farms potentially affect seals and harbour porpoises?* Poster presented to the 14th Biennial Conference on the Biology of Marine Mammals. Vancouver, Canada.
- HERR, H. (2004): *Sichtungshäufigkeit und Verbreitungsmuster von Meeressäugern in deutschen Gewässern - Relation zu Schifffahrts- und Fischereiaktivität*: pp. 1-82. Universität Hamburg, Fachbereich Biologie.
- HILDEBRAND, J. (2004): *Sources of Anthropogenic Sound in the Marine Environment. International Policy Workshop on Sound and Marine Mammals*, pp. 28.-30. Sept. 2004.
- HILL, R. D. (1985): Investigation of lightning strikes to water surface. *J. Acoust. Soc. Am.*, Vol. 78: pp. 2096-2099.
- HOLT, M. M.; SCHUSTERMAN, R. J.; SOUTHALL, B. L. & KASTAK, D. (2004): Localisation of aerial broadband noise by pinnipeds. *J. Acoust. Soc. Am.*, Vol. 115: pp. 2339-2345.
- HUTT, R. (2004): Literature review: *Noise from high pressure water jetting*.
- ILLINGWORTH & RODKIN, I. (2001): *NMFS Marine Mammal Safety Zone*. Final Data Report: Noise and Vibration Measurements Associated with the Pile Installation Project for the San Francisco-Oakland Bay Bridge East Span. D-1-D-10.
- INGEMANSSON TECHNOLOGY AB. (2003): *Utgrunden off-shore wind farm - Measurements of underwater noise*. 11-00329-03012700.
- JOHNSTON, D. W. (2002): The effect of acoustic harassment devices on harbour porpoises (*Phocoena phocoena*) in the Bay of Fundy, Canada. *Biol. Cons.*, Vol. 108: pp. 113-118.
- JOINT NATURE CONSERVATION COMMITTEE (2004): *Guidelines for Minimising Acoustic Disturbance to Marine Mammals from Seismic Surveys*.
- KAMMINGA, C. & WIERSMA, H. (1981): Investigations on cetacean sonar II. Acoustical similarities and differences in odontocete sonar signals. *Aquat. Mamm.*, Vol. 8(2): pp. 41-62.
- KASTAK, D. & SCHUSTERMAN, R.J. (1998): Low-frequency amphibious hearing in pinnipeds: Methods, measurement, noise, and ecology. *J. Acoust. Soc. Am.*, Vol. 103(4), pp. 2216-2228.
- KASTELEIN, R.A., GOODSON, A.D., LIEN, J. & DE HAAN, D. (1995): The effects of acoustic alarms on Harbour porpoise (*Phocoena phocoena*). In: P.E. Nachtigall, J. Lien, W.W.L. Au and A.J. Read (Eds.): *Harbour Porpoises, Laboratory Studies to Reduce Bycatch*. De Spil, Woerden, The Netherlands: pp. 157-167.
- KASTELEIN, R.A., DE HAAN, D., GOODSON, A.D., STAAL, C. & VAUGHAN, N. (1997): The effects of various sounds on a harbour porpoise (*Phocoena phocoena*). In: P.E. Nachtigall, J. Lien, W.W.L. Au and A.J. Read (Eds.): *The Biology of the Harbour Porpoise*. De Spil, Woerden, The Netherlands: pp. 367-383.
- KASTELEIN, R.A., RIPPE, H.T., VAUGHAN, N., SCHOONEMAN, N.M., VERBOOM, W.C. & DE HAAN, D. (2000): The effect of acoustic alarms on the behavior of harbor porpoises (*Phocoena phocoena*) in a floating pen. *Mar. Mamm. Sci.*, Vol. 16: pp. 46-64.

- KASTELEIN, R.A., BUNSKOEK, P., HAGEDOORN, M. & AU, W.W.L. (2002): Audiogram of a harbour porpoise (*Phocoena phocoena*) measured with narrow-band frequency-modulated signals. *J. Acoust. Soc. Am.*, Vol. 112(1), pp. 334-344.
- KETTEN, D.R. (2000): Cetacean Ears. In: W.W.L. Au, A.N. Popper and R.R. Fay (Eds.): *Hearing by Whales and Dolphins*. Springer Handbook of Auditory Research, Vol.12, Springer Verlag, New York, N.Y.: pp. 43-108.
- KHAN, C. B. (2004): *Vocal Development in Harbour Seal Pups, Phoca vitulina*. San Francisco State University.
- KNUST, R.; DALHOFF, P.; GABRIEL, J.; HEUERS, J.; HÜPPOP, O. & WENDELN, H. (2003): *Untersuchungen zur Vermeidung und Verminderung von Belastungen der Meeresumwelt durch Oddshore-Windenergieanlagen im küstenfernen Bereich der Nord- und Ostsee*. German Federal Environmental Protection Agency, Research Report 200 97 106, UBA-FB 000478.
- KOSCHINSKI, S. (2002): Current knowledge on harbour porpoises (*Phocoena phocoena*) in the Baltic Sea. *Ophelia*, Vol. 55: pp. 167-197.
- KOSCHINSKI, S., CULIK, B. (1997): Deterring harbour porpoises from gillnets: observed reactions to passive reflectors and pingers. *Rep. Int. Whal. Comm.*, Vol. 47: pp. 659 – 688.
- KOSCHINSKI, S.; CULIK, B. M.; HENRIKSEN, O. D.; TREGENZA, N.; ELLIS, G.; JANSEN, C. & KATHE, G. (2003): Behavioural reactions of free-ranging porpoises and seals to the noise of a simulated 2 MW windpower generator. *Mar. Ecol. Prog. Ser.*, Vol. 265: pp. 263-273.
- LAAKE, J., RUGH, D. & BARAFF, L. (1998): *Observations of Harbour Porpoise in the Vicinity of Acoustic Alarms on a Set Gill Net*. NOAA Technical memorandum NMFS-AFSC-84.
- LEPPER, P. A.; TURNER, V. I. G.; GOODSON, A. D. & BLACK, K. D. (2004): Source levels and spectra emitted by three commercial aquaculture anti-predator devices. Proceedings of the Seventh European Conference on Underwater Acoustics, ECUA. Delft, The Netherlands.
- LICK, R. & PIATKOWSKI, U. (1998): Stomach contents of a Northern bottlenose whale (*Hyperoodon ampullatus*) stranded at Hiddensee, Baltic Sea. *J. Mar. Biol. Assoc. UK.*, Vol. 78: pp: 643-650.
- LOCKYER, C.; AMUNDIN, M.; DESPORTES, G. & GOODSON, A. D. (2001): EPIC - *Elimination of Harbour Porpoise Incidental Catches*. DG XIV 97/0006.
- LUCKE, K. (2000): *Potentieller Einfluß von akustischen Emissionen auf marine Säugetiere. Wilhelmshafen*. Workshop on Offshore Wind Energy Use, Technology, Conservation, Planning. Deutsches Windenergie-Institut GmbH.
- LUCKE, K.; HANKE, W. & DEHNHARDT, G. (2004): Untersuchungen zum Einfluss akustischer Emissionen von Offshore-Windkraftanlagen auf marine Säuger im Bereich der deutschen Nord- und Ostsee. In: A. Kellermann et al. (Eds.): *Marine Warmblüter in Nord-und Ostsee (MINOS): Grundlagen zur Bewertung von Windkraftanlagen im Offshore-Bereich*. Final Report. Sponsored by the German Federal Ministry of the Environment: pp. 23-76.
- MADSEN, P.T., WAHLBERG, M., TOUGAARD, J., LUCKE, K. & TYACK, P. (2005): Wind turbine underwater noise and marine mammals: Implications of current knowledge and data needs. *Mar. Ecol. Prog. Ser.*, Vol. 309: pp. 279-295.
- MØHL, B. (1968): Auditory sensitivity of of the common seal in air and water. *J. Aud. Res.*, Vol. 8 (1), pp. 27-38.
- MØHL, B. & ANDERSEN, S. (1973): Echolocation: High-frequency component in the click of the harbour porpoise (*Phocoena ph. L.*). *J. Acoust. Soc. Am.*, Vol. 54(5): pp. 1368-1372.
- MORTON, A. B. & SYMONDS, H. K. (2002): Displacement of *Orcinus orca* (L.) by high amplitude sound in British Columbia, Canada. *ICES J. Mar. Sci.*, Vol. 59: pp. 71-80.
- NACHTIGALL, P. E.; PAWLOWSKI, J. & AU, W. W. L. (2003) Temporary threshold shifts and recovery following noise exposure in the Atlantic bottlenosed dolphin (*Tursiops truncatus*). *J. Acoust. Soc. Am.*, Vol. 113: pp. 3425-3429.
- NACHTIGALL, P. E.; SUPIN, A. YA.; PAWLOWSKI, J. & AU, W. W. A. (2004): Temporary threshold shifts after noise exposure in the bottlenose dolphin (*Tursiops truncatus*) measured using evoked auditory potentials. *Mar. Mamm. Sci.*, Vol. 20: pp. 673-687.
- NEDWELL, J. & HOWELL, D. (2004): *A review of offshore windfarm related underwater noise sources*. Tech. Rep. 544R0308. Prepared by Subacoustech Ltd., Hampshire, UK for COWRIE.

- NEDWELL, J.; LANGWORTHY, J. & HOWELL, D. (2003a): *Assessment of sub-sea acoustic noise and vibration from offshore wind turbines and its impact on marine wildlife*; initial measurements of underwater noise during construction of offshore windfarms, and comparison with background noise. Tech. Rep. 544R0424. Prepared by Subacoustech Ltd., Hampshire, UK for COWRIE.
- NEDWELL, J., NEEDHAM, K., GORDON, J., ROGERS, C. & GORDON, T. (2001): *The effects of underwater blast during wellhead severance in the North Sea*. 469 R 0202. Subacoustech Ltd.
- NEDWELL, J.; NEEDHAM, K.; TURNPENNY, A. W. H. & THOMPSON, D. (1999): *Measurement of Sound during a 3D seismic survey in blocks 14/14a of the North Sea*. 356R0108. Subacoustech Ltd.
- NEDWELL, J.; TURNPENNY, A. W. H.; LONGWORTHY, J. & EDWARDS, B. (2003b): *Measurements of underwater noise during piling at the Red Funnel Terminal, Southampton, and observations of its effect on caged fish*. Subacoustech Ltd. 558 R 0207. 2003.
- NEDWELL, J. R.; EDWARDS, B.; TURNPENNY, A. W. H. & GORDON, J. (2004): *Fish and Marine Mammal Audiograms: A summary of available information*. Subacoustech Report ref: 534R0214.
- ØDEGAARD & DANNESKIOLD-SAMSØE A/S (2000): *Offshore Wind-Turbine Construction. Offshore Pile-Driving Underwater and Above-Water Noise Measurements and Analysis*. McKenzie Maxon, Christopher and Winther Nielsen, Ole. 00.877.
- OILFIELD PUBLICATIONS (2003): *The Guide to European Renewable Energy Resources. Volume One - Wind Farms*. Ledbury, England.
- OLESIUK, P. F.; NICHOL, L. M. & FORD, J. K. B. (2002): Effect of the sound generated by an acoustic harassment device on the relative abundance and distribution of harbour porpoise (*Phocoena phocoena*) in retreat passage, British Columbia. *Mar. Mamm. Sci.*, Vol. 18: pp. 843-862.
- OLIVER, G.W. (1978): Navigation in mazes by a grey seal, *Halichoerus grypus* (Fabricius). *Behaviour*, Vol. 67(1-2): pp. 97-114.
- PARSONS, E. C. M.; BIRKS, I.; EVANS, P. G. H.; GORDON, J. C. D.; SHRIMPTON, J. H. & POOLEY, S. (2000): The Possible Impacts of Military Activity on Cetaceans in West Scotland. *Europ. Res. Cet.*, Vol. 14: pp. 185-190.
- POPOV, V.V. & SUPIN, A. YA. (1990): Electrophysiological studies of hearing in some cetaceans and manatee. In: J.A. Thomas und R.A. Kastelein (Eds.): *Sensory Abilities of Cetaceans: Laboratory and Field Evidence*. Plenum Press, New York, U.S.A., pp. 405-415.
- REEVES, R.; STEWART, B. S.; CLAPHAM, P. J. & POWELL, J. A. (2002): *Guide to Marine Mammals of the World*. New York: Chanticleer Press.
- REIJNDERS, P. J. H. (1992): Harbour porpoises *Phocoena phocoena* in the North Sea: Numerical responses to changes in environmental conditions. *Neth. J. Aquat. Ecol.*, Vol. 26: pp. 75-85.
- REYFF, JAMES A. (2003): *Underwater Sound Pressure Associated with the Restrike of the Pile Installation Demonstration Project Piles*. State of California, Department of Transportation.
- RICHARDSON, W. J.; GREENE, C. R., JR.; MALME, C. I. & THOMSON, D. H. (1995): *Marine Mammals and Noise*. London: Academic Press.
- RIDGWAY, S. H. & CARDER, D. A. (1997): Hearing deficits measured in some *Tursiops truncatus*, and discovery of a deaf/mute dolphin. *J. Acoust. Soc. Am.*, Vol. 101: pp. 590-594.
- RIDGWAY, S.H. & JOYCE, P.L. (1975): Studies on seal brain by radiotelemetry. *Rapp. P.-v. Reun. Cons. Int. Explor. Mer*, Vol. 169: pp. 81-91.
- RODKIN, R. B., J. A. REYFF (2004): Underwater sound pressures from marine pile driving. *J. Acoust. Soc. Am.*, Vol. 116 (4 Pt. 2): p. 2648 (abstract).
- ROGERS, T. L. (2003): Factors influencing the acoustic behaviour of male phocid seals. *Aquat. Mamm.*, Vol. 29.2: pp. 247-260.
- SCHEVILL, W.E., WATKINS, W.A. & RAY, C. (1963): Underwater sounds of pinnipeds. *Science*, Vol. 141 (3575): pp. 50-53.
- SCHEVILL, W.E., WATKINS, W.A. & RAY, C. (1969): Click structure in the porpoise, *Phocoena phocoena*. *J. Mammalogy*, Vol. 50: pp. 721-728.
- SCHULTZ-VON GLAHN, M. & BETKE, K. (2003): *Zur Unterwasser-Schallabstrahlung beim Bau und beim Betrieb von Offshore-Windenergieanlagen*. Institut für technische und angewandte Physik GmbH, Oldenburg.
- SCHUSTERMAN, R. J. & VAN PARIJS, S. M. (2003): Pinniped vocal communication: an introduction. *Aquat. Mamm.*, Vol. 29.2: pp. 177-180.



- SHAPIRO, A. D.; SLATER, P. J. B. & JANIK, V. M. (2004): Call Usage Learning in Gray Seals (*Halichoerus grypus*) pp., Vol. 118: pp. 447-454.
- SOUTHALL, B.L., SCHUSTERMAN, R.J. & KASTAK, D. (2000): Masking in three pinnipeds: Underwater, low-frequency critical ratios. *J. Acoust. Soc. Am.*, Vol. 108: pp. 1322-1326.
- SOUTHALL, B.L., SCHUSTERMAN, R.J. & KASTAK, D. (2003): Auditory masking in three pinnipeds: Aerial critical ratios and direct critical bandwidth measurements. *J. Acoust. Soc. Am.*, Vol. 114: pp. 1660-1666.
- STIRLING, I. & THOMAS, J.A. (2003): Relationships between underwater vocalisations and mating systems in phocid seals. *Aquat. Mamm.*, Vol. 29.2: pp. 227-246.
- STONE, C.J. (2003): *The effects of seismic activity on marine mammals in UK waters, 1998-2000*. JNCC Report No. 323.
- SUNDBERG, J. & SÖDERMAN, M. (1999): *Windpower and Grey Seals: An impact assessment of potential effects by sea-based windpower plants on a local seal population*. Anceps Ekologidata, Department of Animal Ecology, Uppsala University.
- TEILMANN, J., CARSTENSEN, J., DIETZ, R. & EDRÉN, S. (2004A): *Effect on seals at Rødsand seal sanctuary from the construction of Nysted Offshore Wind Farm based on aerial surveys*. Ministry of the Environment, Denmark.
- TEILMANN, J., DIETZ, R. & EDRÉN, S. (2004B): *Progress report on aerial surveys of seals at Rødsand seal sanctuary and adjacent seal haulout sites during January-July 2004*. Ministry of the Environment, Denmark.
- TEILMANN, J., TOUGAARD, J., KIRKETERP, T., ANDERSON, K., LABBERTE, S. & MILLER, L.A. (2000): *Habituation to pinger-like sounds shown by harbour porpoises (*Phocoena phocoena*)*. Ph.D. thesis: pp. 127-160. Center for Sound Communication, Institute of Biology, University of Southern Denmark.
- TERHUNE, J.M. (1974): Directional hearing of a harbour seal in air and water. *J. Acoust. Soc. Am.*, Vol. 56: pp. 1862-1865.
- TERHUNE, J.M. (1991): Masked and unmasked pure tone detection thresholds of a harbour seal listening in air. *Can. J. Zool.*, Vol. 69: pp. 2059-2066.
- THOMPSON, D., DUCK, C.D. & MCCONNELL, B.J. (1998): Biology of Seals of the North-East Atlantic in Relation to Seismic Surveys. In: M. Tasker and C. Weir (Eds.): *Proceedings of the Seismic and Marine Mammals Workshop*. London.
- THOMPSON, D. (ed.)(1998): Behavioural and Physical Response of Marine Mammals to Acoustic Disturbance (BROMMAD).
- THORSON, P. (2004) *San Francisco-Oakland Bay Bridge East Span Seismic Safety Project. Revised Marine Mammal Monitoring Plan*. EA 012024 and 0120E4, 04-SF-80 KP 12.2/KP 14.3.
- THORSON, P. & REYFF, J.A. (2004) *San Francisco - Oakland Bay Bridge East Span Seismic Safety Project. Marine Mammal and Acoustic Monitoring for the Eastbound Structure*. EA 012023, 04-SF-80 KP 12.2/KP 14.3.
- TOUGAARD, J., CARSTENSEN, J., HENRIKSEN, O.D., SKOV, H. & TEILMANN, J. (2003A): Short-term effects of the construction of wind turbines on harbour porpoises at Horns Reef. Technical report to TechWise A/S. HME/362-02662. Hedeselskabet, Roskilde.
- TOUGAARD, J., CARSTENSEN, J., HENRIKSEN, O.D., TEILMANN, J. & HANSEN, J.R. (2004): *Harbour Porpoises on Horns Reef - Effects of the Horns Reef Wind Farm. Annual Status Report 2003* to Elsam Engineering A/S. NERI Technical Report.
- TOUGAARD, J. & TEILMANN, J. (2004): *Progress report of the acoustic T-POD monitoring during January-July 2004*. Short Tech Note to Energi E2 A/S. Ministry of the Environment, Denmark.
- VAGLE, S. (2003): *On the Impact of Underwater Pile-Driving Noise on Marine Life*. Institute of Ocean Sciences.
- VAN HAAFTEN, J.L. (1981): The common harbour seal (*Phoca vitulina*). In: Reijnders, P.J.H. (ed.): *Marine Mammals of the Wadden Sea*: 15-19.
- VERBOOM, W.C. & KASTELEIN, R.A. (1995): Structure of harbour porpoise (*Phocoena phocoena*) click train signals. In: A.J. Read, P.R. Wiepkema and P.E. Nachtigall (eds.): *The Biology of the Harbour Porpoise*, De Spil Publishers, Woerden, the Netherlands: pp. 343-362.

- WARTZOK, D. & KETTEN, D.R. (1999): Marine Mammal Sensory Systems. In: J.E. Reynolds, III. and S.A. Rommel (Eds.): *Biology of Marine Mammals*. Smithsonian Institution Press, Washington and London: pp. 117-175.
- WOLSKI, L.F., ANDERSON, R.C., BOWLES, A.E & YOCHER, P.K. (2003): Measuring hearing in the harbour seal (*Phoca vitulina*): Comparison of behavioural and auditory brainstem re-sponse techniques. *J. Acoust. Soc. Am.*, Vol.113(1), pp. 629-637.
- WOODS, M.P., VILCHECK, M.G. & WRIGHTSON, B.B. (2001): *Pile Installation Demonstration Project (PIDP) Construction Report*. CONTRACT 04-012084, 04-Ala-80-0.0/0.5. California Department of Transportation, District 04.
- WÜRSIG, B., GREENE, C.R., JR. & JEFFERSON, T.A. (2000): Development of an air bubble curtain to reduce underwater noise of percussive piling. *Mar. Env. Res.*, Vol. 49: 79-93.
- ZIELKE, W., MITTENDORF, K., NGUYEN, B., UNGRUH, G., GERASCH, W.-J., UHL, A., RICHWIEN, W., LESNY, K., WIEMANN, J., SCHAUMANN, P. & KLEINEIDAM, P. (2004): *Bau- und umwelttechnische Aspekte von Off-shore Windenergieanlagen*. Final Report 2000-2003. GIGAWIND. 0329894A. Sponsored by the German Federal Ministry of Economics and Technology.